

# MGT 60M – 600M

## SYSTEM 7 – TWIN ALTERNATING 2" NXT2 SERIES



**Standard Photograph**  
Equipment appearance may differ.  
Twin system shown with skid mount option.

## COMMERCIAL WATER CONDITIONER INSTALLATION, OPERATION, AND MAINTENANCE MANUAL

COMPLETE FOR FUTURE REFERENCE:

MODEL NO:

SERIAL NO:

DATE INSTALLED:

DEALER:

# INSTALLATION WARNING

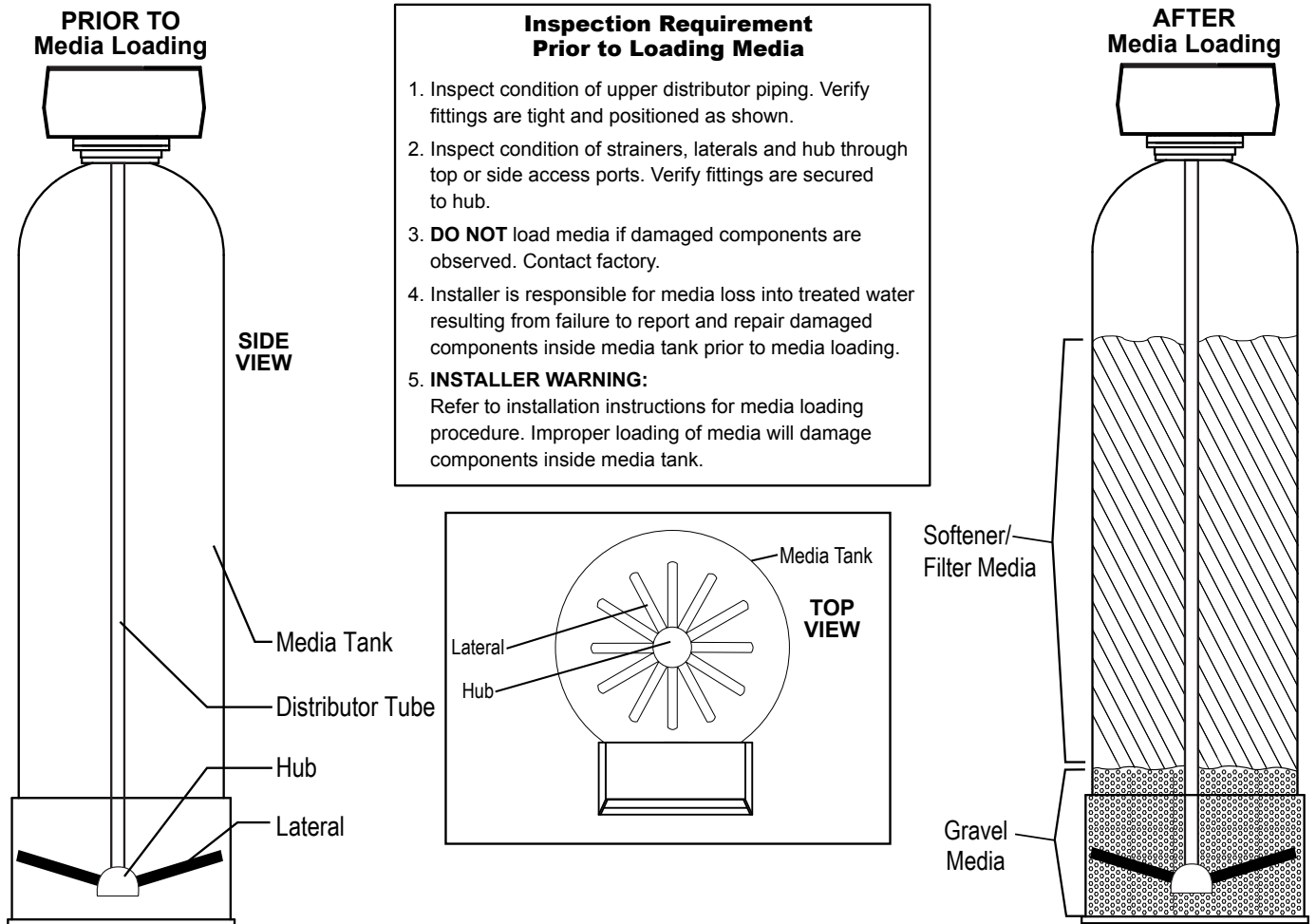

**IMPORTANT PLEASE READ:**

- **Warranty of this product extends to manufacturing defects.**
- **The information, specifications and illustrations in this manual are based on the latest information available at the time of printing. The manufacturer reserves the right to make changes at any time without notice.**
- **This product should be installed by a plumbing professional on potable water systems only.**
- **This product must be installed in compliance with all local and state and municipal plumbing and electrical codes. Permits may be required at the time of installation.**

# **MGT 2” 60M–600M NXT2 TWIN ALTERNATING**

---

## **TABLE OF CONTENTS**

### **SYSTEM INFORMATION**

Product Warranty.....	1
General Arrangement Drawings.....	2
Dimension Chart.....	4
Specification Chart.....	5

### **INSTALLATION**

General Information.....	6
Loading Softener.....	7
Mounting Control Valve.....	7
Brine Tank Installation.....	8
Mounting Water Meter.....	9
Network Communication Cables/Connections.....	9
Power Supply Wiring.....	10
Connection Piping Installation.....	10

### **OPERATION**

Timer Display Features.....	11
System Operation.....	12
Timer Operation.....	12
Start-Up Procedures.....	14
User Mode Programming Flow Chart.....	15
Batch Size Calculation.....	16
Diagnostic Mode Flow Chart.....	17
Master Programming Flow Chart.....	18
Master Programming Guide.....	20
Flow Diagrams.....	21
Wiring Diagram.....	27

### **MAINTENANCE**

Powerhead Assembly.....	28
NXT2 Timer Assembly.....	30
Control Valve Assembly.....	31
Brine Injector Assemblies.....	33
Meters and Flow Sensors.....	36
Brine Tank Assemblies.....	41
Service Assemblies.....	45
Troubleshooting.....	46

# **MGT 2" 60M-600M NXT2 TWIN ALTERNATING SYSTEM INFORMATION**

---

## **COMMERCIAL AND INDUSTRIAL PRODUCT WARRANTY**

Manufacturer warrants all commercial and industrial water treatment products manufactured and/or distributed by it to be free from defects in materials and workmanship for a period of one (1) year after installation or eighteen (18) months from the date of shipment, whichever comes first. The fiberglass mineral tank(s) alone have a warranty for a period of five (5) years from the date of shipment. If within that period any products shall be proven to Manufacturer's satisfaction to be defective, those products will be replaced or the price refunded at Manufacturer's option.

Manufacturer's obligations or nonperformance, defective, or any damage caused by its products or their use, and buyer's exclusive remedy therefore, shall be limited to product replacement or refund and shall be conditioned upon Manufacturer's receiving written notice together with a demand for such replacement or refund:

The foregoing warranty is exclusive and in lieu of all other expressed implied warranty (except of title) including but not limited to implied warranty of merchantability and fitness for particular purpose.

Manufacturer will not be subject to and disclaims the following:

1. Any other obligations or liabilities arising out of breach of contract or out of warranty.
2. Any obligations whatsoever arising from tort claims (including negligence and strict liability or arising under other theories of law with respect to products sold or services rendered by Manufacturer or any undertakings, acts, or omissions relating thereto.
3. All consequential, incidental, and contingent damages.

Labor charges, charge backs or handling charges are excluded from Manufacturer's warranty provisions.

## **COMMERCIAL AND INDUSTRIAL WATER SOFTENER GUARANTEE**

Under normal operating conditions:

1. The softener effluent shall be zero soft as determined by a soap test.
2. The loss of softening resin through attrition during the first three (3) years shall not exceed 3% per year.
3. The softening resin shall not be washed out of the system during backwash.
4. The color and turbidity of the softener effluent shall not be greater than the incoming water.





# MGT 2" 60M-600M NXT2 TWIN ALTERNATING SYSTEM INFORMATION

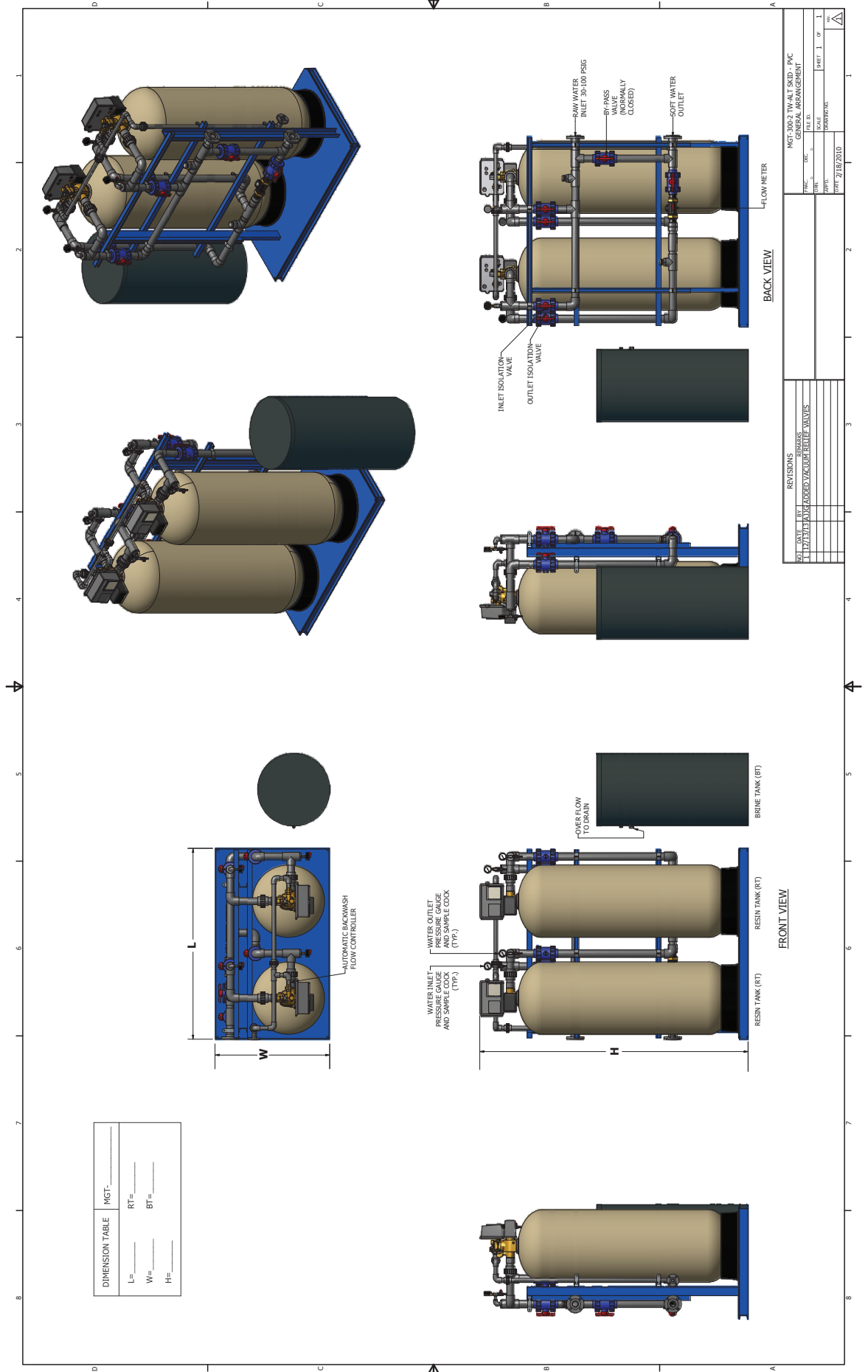

**DIMENSION TABLE**

MGT-	
RT=	
BT=	
L=	
W=	
H=	

**REVISIONS**

NO.	DATE	BY	REVISIONS
1	11/21/2010	PC	ADD BYPASS VALVE TO RESIN TANKS
2	11/21/2010	PC	ADD BYPASS VALVE TO RESIN TANKS
3	11/21/2010	PC	ADD BYPASS VALVE TO RESIN TANKS
4	11/21/2010	PC	ADD BYPASS VALVE TO RESIN TANKS
5	11/21/2010	PC	ADD BYPASS VALVE TO RESIN TANKS
6	11/21/2010	PC	ADD BYPASS VALVE TO RESIN TANKS
7	11/21/2010	PC	ADD BYPASS VALVE TO RESIN TANKS
8	11/21/2010	PC	ADD BYPASS VALVE TO RESIN TANKS
9	11/21/2010	PC	ADD BYPASS VALVE TO RESIN TANKS
10	11/21/2010	PC	ADD BYPASS VALVE TO RESIN TANKS

MGT-3002 TWIN ALT SKID - PVC  
GENERAL ARRANGEMENT  
REV. D  
DATE: 2/18/2010

# MGT 2" 60M-600M NXT2 TWIN ALTERNATING SYSTEM INFORMATION

## DIMENSION CHART

MODEL	INLET SIZE (Inches)	TANK SIZE		LENGTH (Inches)	WIDTH (Inches)	HEIGHT* (Inches)
		SOFTENER (Inches)	BRINE (Inches)			
60	2	12x52	18x40	64	18	69
90	2	14x65	18x40	66	18	79
120	2	16x65	24x40	77	24	79
150	2	18x65	24x50	82	24	81
210	2	21x62	24x50	83	24	81
240	2	24x72	24x50	89	24	88
270	2	24x72	24x50	89	24	88
300	2	24x72	24x50	89	24	88
450	2	30x72	30x50	107	30	89
600	2	36x72	39x48	129	39	89

\*Leave a minimum 24 inch clearance to the height of the unit for loading media.  
Dimensions are for general arrangement use only.

# MGT 2" 60M-600M NXT2 TWIN ALTERNATING SYSTEM INFORMATION

## SPECIFICATION CHART

SYSTEM SIZE	MODEL	60	90	120	150	210	240	270	300	450	600		
	VALVE SIZE (IN)	2	2	2	2	2	2	2	2	2	2	2	
	MAX CAPACITY (KILOGRAINS)	60	90	120	150	210	240	270	300	450	600		
	MIN CAPACITY (KILOGRAINS)	40	60	80	100	140	160	180	200	300	400		
FLOWRATE (GPM)	CONTINUOUS FLOWRATE (GPM)	33	39	47	61	60	74	71	68	84	87		
	PEAK FLOWRATE (GPM)	49	54	64	80	77	97	94	91	105	110		
	BACKWASH & FAST FLUSH (GPM)	3.5	5	6	8	12	15	15	15	25	30		
	BRINE DRAW & RINSE (GPM)	1	1	1.2	1.5	2.8	3.2	3.2	3.2	4.7	4.7		
	BRINE TANK REFILL (GPM)	1	1	1	2	2	2	2	2	5	5		
TIMER SETTINGS	BACKWASH & FAST FLUSH (MIN)	10	10	10	10	10	10	10	10	10	10		
	BRINE DRAW & RINSE (MIN)	60	60	60	60	60	60	60	60	80	80		
	FAST FLUSH (MIN)	10	10	10	10	10	10	10	10	10	10		
	BRINE TANK REFILL (MIN)	10	15	20	13	18	20	23	25	15	20		
SOFTENER TANK	SIZE (IN)	13x54	14x65	16x65	18x65	21x62	24x72	24x72	24x72	30x72	36x72		
	GRAVEL (LBS)	0	30	35	40	80	120	120	120	225	400		
	RESIN (FT <sup>3</sup> )	2	3	4	5	7	8	9	10	15	20		
	FREEBOARD (IN)	16	21	21	24	18	30	25	21	22	23		
BRINE SYSTEMS	EQUIPMENT	TANK SIZE	18x40	18x40	24x40	24x50	24x50	24x50	24x50	24x50	30x50	39x60	
		MAX SALT STORAGE (LBS)	270	270	530	630	540	510	490	410	640	1700	
		INJECTOR CODE	3	3	4	3C	4C	5C	5C	5C	6C	6C	
		INJECTOR COLOR	YEL	YEL	GRN	YEL	GRN	WHT	WHT	WHT	RED	RED	
	MAX	SALT DOSAGE- MAX (LBS)	30	45	60	75	105	120	135	150	225	300	
		REFILL TIME - MAX (MIN)	10	15	20	13	18	20	23	25	15	20	
		MIN	SALT DOSAGE- MIN (LBS)	12	18	24	30	42	48	54	60	90	120
			REFILL TIME - MIN (MIN)	4	6	8	5	7	8	9	10	6	8
REGENERATION WASTE VOLUME (GAL)	126	156	188	228	366	520	536	544	860	1020			

### NOTES:

#### 1. FLOW RATES

**Continuous:** pressure loss does not exceed 15 psig.

**Peak:** pressure loss does not exceed 25 psig

**Backwash & Flush:** maximum flow to drain

**Brine & Rinse:** Injector flow to drain

**Brine Tank Refill:** flow to refill Brine Tank

#### 2. SOFTENER TANK

Freeboard: distance in inches from surface of resin to top sealing flange of tank

#### 3. SALT DOSAGE

Maximum 15 lbs./cu.ft. - regeneration efficiency: 2,000 grains/pound of salt (factory setting)

Maximum 6 lbs./cu.ft. - regeneration efficiency: 3,000 grains/pound of salt

#### 4. REGENERATION WASTE VOLUME - Total gallons water discharged per regeneration

#### 5. OPERATING LIMITS:

Minimum operating pressure is 30 psi.

Maximum operating pressure is 120 psi.

Standard units are designed to soften unheated water within the range of 35-100°F.

#### 6. POWER

Power requirements are 120 Volt, 60 Hertz, Single Phase, 2 amps noninterrupted.

#### 7. SALT

Salt specifications are pelletized or solar salt, 99% pure, containing less than 1% insolubles (see Brine Tank Installation on page 8)

# **MGT 2” 60M–600M NXT2 TWIN ALTERNATING INSTALLATION**

---

## **INSTALLATION INSTRUCTIONS WATER SOFTENERS**

### **GENERAL INFORMATION**

1. Operating pressure range is 30-100 psi. If pressures over 100 psi are encountered, a regulator must be installed.

**NOTE:** The control valve will not operate correctly if feeding into an atmospheric tank. A pressure control device must be added to the outlet to maintain the minimum pressure.

2. Power requirements are shown on inside cover of the control valve. You can also tell by wire color on the motor: Black wires are 115 volt. Yellow wires are 220 volt. Blue wires are 24 volt.

3. Standard units are designed to soften unheated water not to exceed 100F. Special valve assemblies are available to handle heated water supplies exceeding 100 F. Consult factory if applicable.

4. Each softener tank is shipped with distributor manifold and control valve preassembled. Take care when uncrating and erecting so that no items are damaged.

5. The distributor assembly has been shipped inside the fiberglass mineral tank. Check to make sure that there is no damage to the riser pipe, baskets, laterals, or hub prior to loading media.

**NOTE: A prefilter should be used on installations in which free solids are present.**

### **LOCATE SOFTENER**

1. Select a location that is accessible and near a floor drain that has adequate carrying capacity to handle the softener regeneration flow. See specification table for the flow rate. Allow a minimum of 24” above the tank for loading media.

2. Erect the softener tank(s) on a concrete or other firm foundation and level

**NOTE:** If the system is skid mounted, it may be prepped and preloaded at the factory. Skip the following instructions and go to the section “Installation of Connection Piping” if unit is preloaded.

3. Position the brine tank according to the illustration and supplementary brine tank information. Keep the brine tank as close as possible to the softener tank(s).

**NOTE:** The distance between the softener and brine tanks will affect the brine injector performance, as the distance increases the injector performance decreases. This may cause an inadequate regeneration. Maximum recommended distance is 5 ft.

4. A grounded electric receptacle is required for the control valve transformer.

# MGT 2" 60M-600M NXT2 TWIN ALTERNATING INSTALLATION

## LOAD SOFTENER TANK

**IMPORTANT:** Be sure to visually inspect the lower laterals prior to loading the media. Check to make sure each lateral is firmly threaded into the hub.

1. Fill a tank approximately 1/3 full of water using a hose, bucket, etc. Plug the PVC distributor manifold pipe using a plastic cap, cork, rag, etc. No gravel or resin should go into this distributor manifold pipe.
2. Verify the distributor manifold is center in the tank with the distributor resting on the bottom of the tank. Verify the riser pipe is still plugged.

**NOTE:** Reference the specification table in the front of this manual for the correct quantities of gravel and resin. These quantities are for each tank. Make sure you have the required amounts on site before you begin.

3. With care not to damage any lateral, pour in the gravel provided for each tank through the top opening in the tank and level out evenly. This will cover the distributor assembly.

**NOTE:** Wetting the gravel in the bags before loading will eliminate the normal amount of dust.

4. When gravel is loaded and leveling is completed, proceed as follows:
5. With the distributor riser pipe still plugged, add the proper amount of resin supplied for each tank through the top opening in the tank.

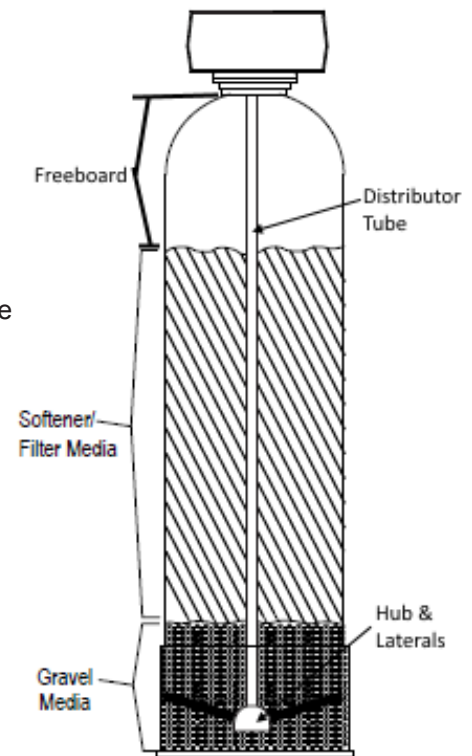

**CAUTION:** The softener resin is very slippery. Take care when stepping on any spilled resin. Remove spilled resin from standing surface immediately.

6. When loading is complete, remove plastic cap, cork, or rag that was used to plug the distributor riser pipe. Be careful not to let any foreign debris fall into the pipe. The result could be damage to system.
7. Repeat instruction steps 1-7 for each softener tank if applicable.

## MOUNT CONTROL VALVE ASSEMBLY

1. Verify that the distributor riser pipe is not plugged.
2. Lubricate the distributor o-ring on the bottom of the control valve with silicone.
3. Insert disperser in threaded base of control valve. The threaded base has a groove machined into the inside of the threaded part of the base to allow for the installation of this disperser.
4. Screw control valve into top opening of tank making sure the distributor riser pipe slides easily through the distributor o-ring. Care must be taken not to "nick" this o-ring as hard water leakage could result.
5. Tighten down the control valve to ensure positive o-ring seal at top of tank.
6. Repeat instruction steps 1-5 for each softener tank (if applicable).

# MGT 2" 60M-600M NXT2 TWIN ALTERNATING INSTALLATION

## BRINE TANK INSTALLATION

The brine tank should be installed on a smooth level surface. If none is available, the tank should be placed on a smooth piece of exterior plywood and leveled by placing shims underneath the plywood. Make sure that the salt shelf inside the tank is level and that the brine well is near to vertical as possible. The brine valve float is used as a safety overflow and should be high on the float rod. It is not used to stop the refill. If the float is near the salt shelf, move the float up near the top of the valve.

Note: Brine valve assembly will not sit on bottom of brine tank.

Using the tubing supplied in the brine tank, connect one end to the brine valve in the brine tank ("A") to the brine injector port on the valve ("B"). There should be an insert and enough brine tubing to reach from the brine valve to the control valve. For systems that use a 1600 brine valve, the tubing will be 3/8" OD. For systems that use the 1700 brine valve, the tubing will be 1/2" OD. 18 feet of tubing is included with the system.

A duplex system also includes a tubing tee for connection from the brine tank to both control valves.

After connecting the tubing on both ends, verify that the brine line tubing is not kinked or restricted.

Run flexible tubing (not provided) from the brine tanks over flow fitting to an appropriate, non-elevated, open drain.

Using a bucket or hose, fill brine tank with water to about 2" above salt platform. Do not add salt at this time.

Note:: In the process of making brine for the first regeneration, the solution volume will increase (one gallon of water will be 1.2 gallons of brine). The final level of the liquid will be several inches above the platform.

## RECOMMENDED TYPES OF SALT

Only purified salt should be used in the brining system. Palletized salt ("Button", "Nugget", and "Pellet") or block salt (free binders) is recommended. Do not use granulated salt, as it will fall through the platform screen.

Rock salt is not normally recommended. Most rock salt contains sludge-forming insoluble that collect on the platform and prevents proper salt-water contact.

Only salt containing 0.5% or less of insolubles will provide continued satisfactory operation. If salt with more insolubles is used, the brine maker will require periodic cleaning.

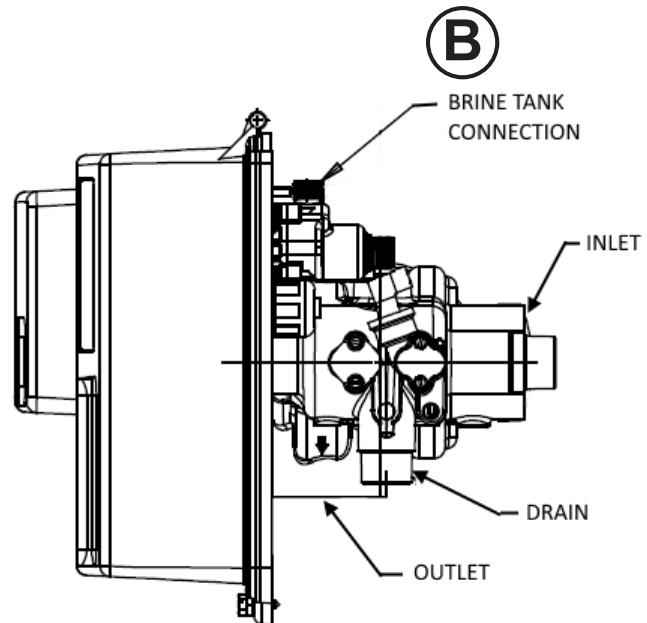
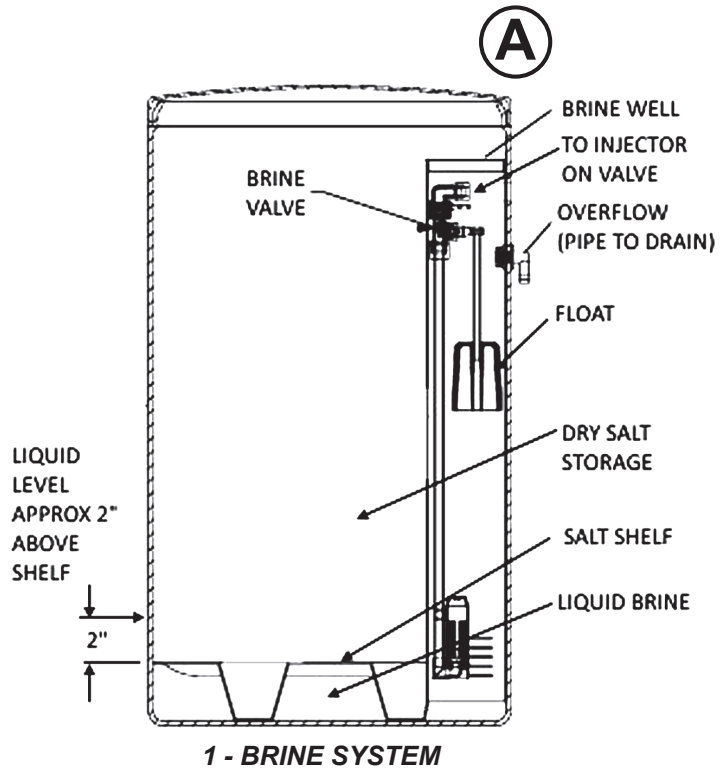



# MGT 2" 60M-600M NXT2 TWIN ALTERNATING INSTALLATION

## MOUNTING WATER METER ASSEMBLY (IF UNIT IS NOT SKID MOUNTED)

1. Locate the meter. The meter may or many not have the cable attached. If not, locate the cable as well.
2. For a twin alternating system, the meter must be installed in the common outlet of the softeners. Refer to the General Arrangement drawing on page two (2). The water meter has a flow arrow stamped on it. The flow arrow on the meter should be pointing away from the softeners.
3. After installing the meter, insert the meter end of the cable into the meter dome if necessary. Then run the meter cable along the piping back to the unit 1 control valve.
4. Run the cable through a cable grip and into the back of the control and into the controller. Connect the meter cable to the circuit board in the lower right as shown.

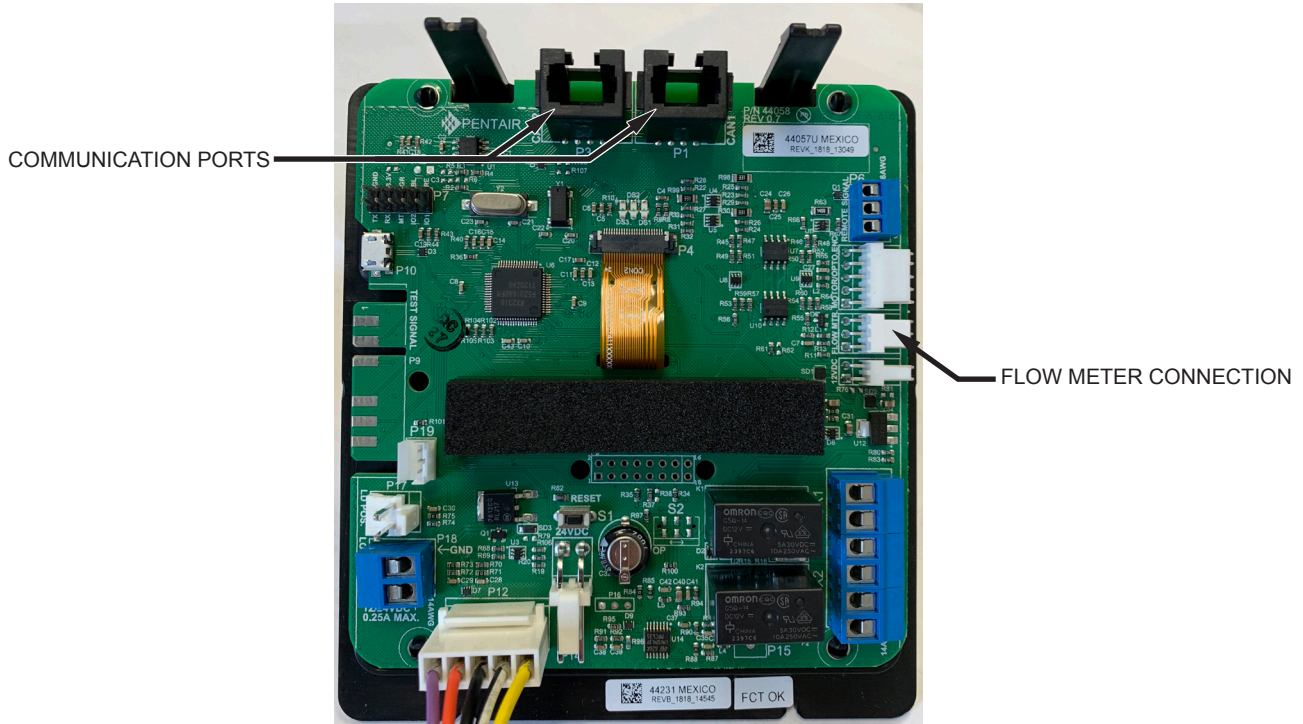

## NETWORK/COMMUNICATION CABLES & CONNECTIONS

Use either a CAT3 or CAT5 Network/Communication cable.

1. Connect the network/communication cable first before programming.
2. The maximum cable length between timers is 100 feet.
3. Connect each unit in series (do not form a loop) from one communication port to the next communication port. It does not matter which one goes to the next one.

The number of network/communication cables needed for setup is one less than the total number of valves.

- Two-Unit System:** One network/communication cable
- Three-Unit System:** Two network/communication cables
- Four-Unit System:** Three network/communication cables

## NETWORK TIMER SYSTEM 7 TWIN ALTERNATING CONFIGURATION WIRING

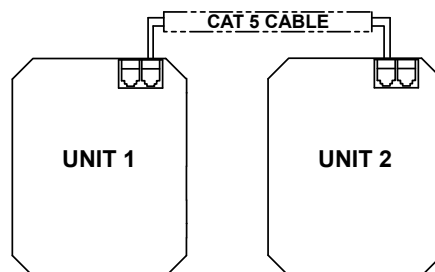



# MGT 2" 60M-600M NXT2 TWIN ALTERNATING INSTALLATION

## POWER SUPPLY INSTALLATION

**NOTE: POWER SUPPLY INCLUDES A HARNESS WITH 2 BLACK WIRES THAT CONNECT TO THE CIRCUIT BOARD.**

1. Insert black and black transformer wires into 24VDC input of control.

### 2510/2750/2815/2850/2900 Valves:

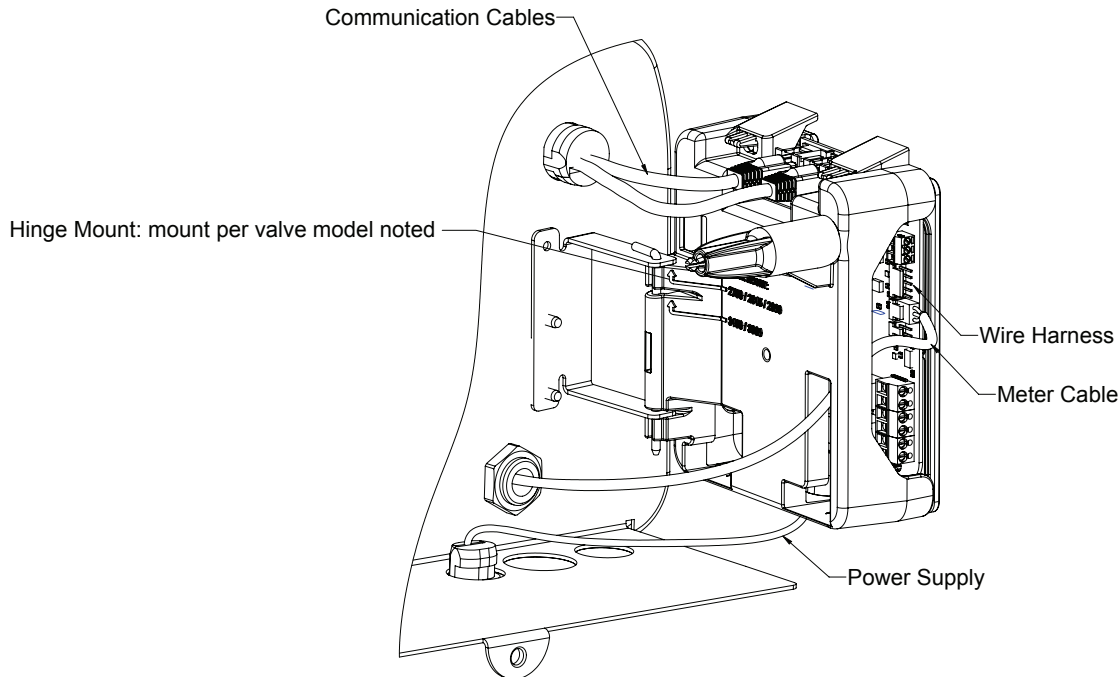

## INSTALLATION OF CONNECTION PIPING

### NOTE:

- Use thread sealing tape on all threaded piping connections.
- Install the piping conforming to federal, provincial, and local codes.
- Union or flanges are recommended at the control valve's inlet, outlet, and drain connections
- To enhance the monitoring of the system's performance sample valves and pressure gauges can be installed at the inlet and outlet piping to each control valve.

**Caution:** All piping must be properly supported. The tank and valve assemblies are not meant to support the connecting piping.

1. Install piping as shown on installation diagram. It is recommended that unions be installed on inlet and outlet connections to facilitate service of unit. Be sure piping is free of thread chips and other foreign matter. The connecting piping should be the same size or larger than the service inlet and outlet of the control valve. On multiple units that are both in service at the same time the common service inlet and outlet headers should be up-sized to accommodate the total flow
2. Verify that the flow arrow stamped on the brass flow controller is pointing away from the control valve. See installation diagram or valve manual for the location. Install a drain line from backwash control assembly to an appropriate drain using a minimum of elbows. Install a union near the backwash control to facilitate cleaning. Do not install a valve on the drain line.

### NOTE:

- If distance of drain line is over a 10 ft. vertical or 25 ft. horizontal run, increase drain line one pipe size over that provided on the control valve.
- Do not make a direct connection to the drain. Provide an air gap of at least four times the diameter of the pipe to conform to sanitation codes and to permit observation of the flow.
- It is not recommended that an overhead or a long horizontal drain run be used. The increase of backpressure will cause problems when drawing brine.

# MGT 2" 60M-600M NXT2 TWIN ALTERNATING OPERATION

## TIMER DISPLAY FEATURES

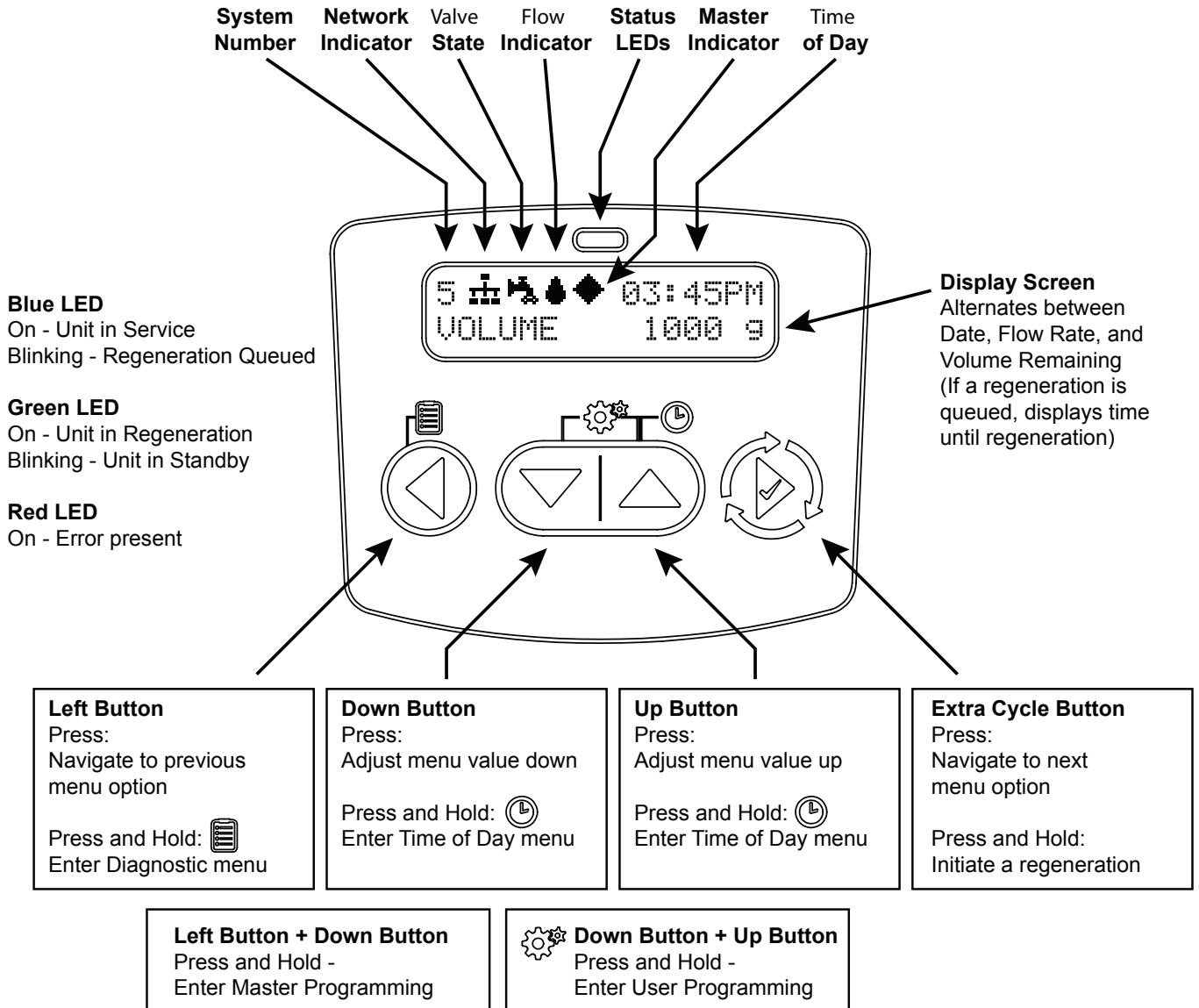

## Display Icons

- |  |                                  |  |                         |
|--|----------------------------------|--|-------------------------|
|  | Valve State: Service             |  | Lock Window             |
|  | Valve State: Standby             |  | Initializing            |
|  | Flow Indicator (flashing)        |  | Upper Drive Movement    |
|  | Regeneration                     |  | Lower Drive Movement    |
|  | Master Unit (auto-assigned)      |  | Remote Regeneration     |
|  | Network Indicator - Connected    |  | Master Programming      |
|  | Network Indicator - Disconnected |  | User Programming        |
|  | Network Indicator - Unit Missing |  | Diagnostics             |
|  | USB Connected (Field Programmer) |  | Time of Day Programming |
|  | Error Condition Present          |  |                         |
|  | Remote Lock                      |  |                         |

# **MGT 2" 60M-600M NXT2 TWIN ALTERNATING OPERATION**

---

## **SYSTEM OPERATION**

### **System 7 (2 Units) Alternating Immediate**

One tank online supplying treated water, one tank in Standby. Only #1 control will monitor its flow meter/sensor input. Regeneration of a unit will begin after the other control has left Standby and returned to Service. When the Regeneration cycle is complete, the regenerated unit will enter Standby. Standby on each tank is controlled by the relay on the NXT2 circuit board.

## **TIMER OPERATION**

### **TIMER OPERATION DURING PROGRAMMING**

The timer enters the Program Mode in standby or service mode as long as it is not in regeneration. While in the Program Mode the timer continues to operate normally monitoring water usage. Timer programming is stored in memory permanently.

### **TIMER OPERATION DURING A POWER FAILURE**

All program settings are stored in permanent memory. Current valve position, cycle step time elapsed, and time of day are stored during a power failure, and will be restored upon power re-application. Time is kept during a power failure, and time of day is adjusted upon power up (as long as power is restored within 12 hours).

### **NOTE:**

The time of day on the main display screen will flash for 5 minutes when there has been a power outage. The flashing of the time of day can be stopped by pressing any button on the display.

### **REMOTE LOCKOUT**

The timer does not allow the unit/system to go into Regeneration until the Regeneration Lockout Input signal to the unit is cleared. This requires a contact closure to activate the unit. The recommended gauge wire is 16 AWG with a maximum wire length run of 50 feet.

### **REGENERATION DAY OVERRIDE FEATURE**

If the Day Override option is turned on and the valve reaches the set Regeneration Day Override value, the Regeneration Cycle starts if no other unit is in Regeneration. If other units are in regeneration, it is added to a regeneration queue. This occurs regardless of the remaining volume available.

### **FLOW METER EQUIPPED TIMER**

As treated water is used, the Volume Remaining display counts down from the calculated system capacity to zero. When zero is reached, a Regeneration Cycle begins if no other units are in regeneration.

# MGT 2” 60M–600M NXT2 TWIN ALTERNATING OPERATION

## TIMER OPERATION

### SETTING THE TIME OF DAY

**NOTE: Set Time of Day on any unit and the rest of the units in the system will update the Time of Day automatically.**

1. Press and hold the Up button for 2 seconds. The “Time” value is displayed. Press the Up or Down buttons to adjust as desired.
2. Press the Extra Cycle button to advance to the “Year” field. Press the Up or Down buttons to adjust as desired.
3. Press the Extra Cycle button to advance to the “Month” field. Press the Up or Down buttons to adjust as desired.
4. Press the Extra Cycle button to advance to the “Calendar Day” field. Press the Up or Down buttons to adjust as desired.
5. Press the Extra Cycle button to return to the normal display screen.

**NOTE: Press and hold the Left button to exit without saving.**

### MANUALLY INITIATING A REGENERATION

1. When timer is In Service or Standby, press and hold the Extra Cycle button on the main screen.
2. The timer advances to Regeneration Cycle Step #1, and begins programmed time count down.
3. Press the Extra Cycle button once to advance valve to Regeneration Cycle Step #2 (if active).
4. Press the Extra Cycle button once to advance valve to Regeneration Cycle Step #3 (if active).
5. Press the Extra Cycle button once to advance valve to Regeneration Cycle Step #4 (if active).
6. Press the Extra Cycle button once to advance valve to Regeneration Cycle Step #5 (if active).
7. Press the Extra Cycle button once more to advance the valve back to In Service.

**NOTE: A manually initiated or queued regeneration can be cleared by pressing and holding the Back button. A system queued regeneration can only be cleared by stepping through a manual regeneration. If regeneration occurs for any reason prior to the delayed regeneration time, the manual regeneration request shall be cleared. Pressing the Extra Cycle button while in regeneration will cause the upper drive to advance to the next step immediately.**

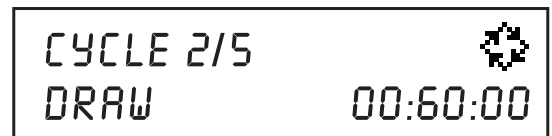
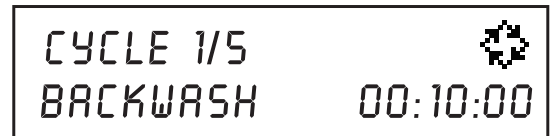

In the Regeneration Cycle step display, the timer shows the current regeneration cycle name the valve is in, or has reached, and the time remaining in that step. Once all regeneration steps are complete, the timer returns to In Service and resumes normal operation.



Press the Extra Cycle button during a system queued Regeneration Cycle to immediately advance the valve to the next cycle step position and resume normal step timing.

### LOCK SETTINGS (ACCESS TO MASTER PROGRAMMING)

Lock Settings prevents the user from accessing Master Programming. In Master Programming, select the desired Lock Settings option (Off, Time Based, Delayed, or Enter Code).

**Time Based** - User must set clock to 12:01 pm to unlock

**Delayed** - User must press and hold the Left and Down buttons for 60 continuous seconds to unlock

**Enter Code** - User must input code “1201” to unlock

### SETTINGS REVIEW

To prevent unintentional changes to Master Programming, enable Settings Review to view and navigate through Master Programming settings without the ability to edit.

# MGT 2" 60M-600M NXT2 TWIN ALTERNATING OPERATION

---

## **START-UP PROCEDURES**

Again, make sure all plumbing is complete and tight, including drain line and brine line. Make sure all electrical components, including the communication cables (multi tank systems only) are properly installed and connected.

1. Using a bucket or hose, fill brine tank with water to 2" above salt platform. Do not add salt at this time.
2. Make sure inlet and outlet isolation valves are closed, and then turn on power to the system.

**Note:** Start up only one (1) tank at a time.

3. Open the manual bypass valve. The manual inlet and outlet valves are to remain closed.
4. Connect electrical power to the control valve by plugging in the valve. Once the valve is powered it will drive to the service position. The LED light should be blue.
5. Program the NXT2 controller. The water hardness, day override, time of regeneration, and time of day will need to be set on site to the desired settings. (Refer to the User Mode Programming section of the manual.) The softener settings are pre-programmed at the factory. Instructions for changing these settings are in the Master Programming Guide section.
6. Manually initiate a regeneration by pressing and holding the Extra Cycle button on the NXT2 controller.
7. The LED light on the NXT2 timer should change from Blue indicating the unit is In Service color to Green indicating the unit is in Regeneration.
8. Slowly open the manual inlet supply valve of the unit that is in backwash. Do not open the valve fully. Water will enter from the bottom of the mineral tank as air is expelled from the top to the drain. Full flow of water could cause loss of mineral. Continue to fill slowly until all air is expelled and only water flows to the drain.
9. When only water flows to the drain, open the inlet valve fully and backwash the unit until the water looks clean when caught in a container.
10. Press the Extra Cycle push button to advance the valve to the Brine/Rinse position.
11. While the unit is in the brine/rinse position, check the level in the brine tank. The level should be dropping at a slow rate (approximately 2" per minute). Allow the level to drop until the air check valve closes.
12. Press the Extra Cycle push button to advance the valve to the Fast Flush position. Allow the water to flow to the drain until clear.
13. Press the Extra Cycle push button to advance the valve to the Brine Tank Refill position. Allow the brine tank to fill with water for the duration of the step. The water level should be 1"-2" inches above the salt platform.
14. Press the Extra Cycle push button to advance the valve to the Service/Standby position.
15. If applicable repeat steps 3 - 13 for the other unit(s).
16. Fill the brine tank with the proper amount and type of salt recommended for use with the system.
17. Close the manual bypass valve and open all outlet valves fully. The system is now in service.

### **Program Notes:**

- The valve programmed as initially will be the Lead unit.
- The Meter must be connected to the Lead unit.- Unit 1

# MGT 2” 60M–600M NXT2 TWIN ALTERNATING OPERATION

## USER MODE PROGRAMMING FLOW CHART

1. To navigate, press the Extra Cycle button to advance to the next value. Press the Left button to retreat to the previous value.
2. Where applicable, use the Up and Down buttons to adjust a value as desired.
3. After progressing through all available values, the timer will return to Normal operation.
4. Depending on the current controller programming, certain values may not be able to be viewed or set.
5. The timer will display local information, not system information.

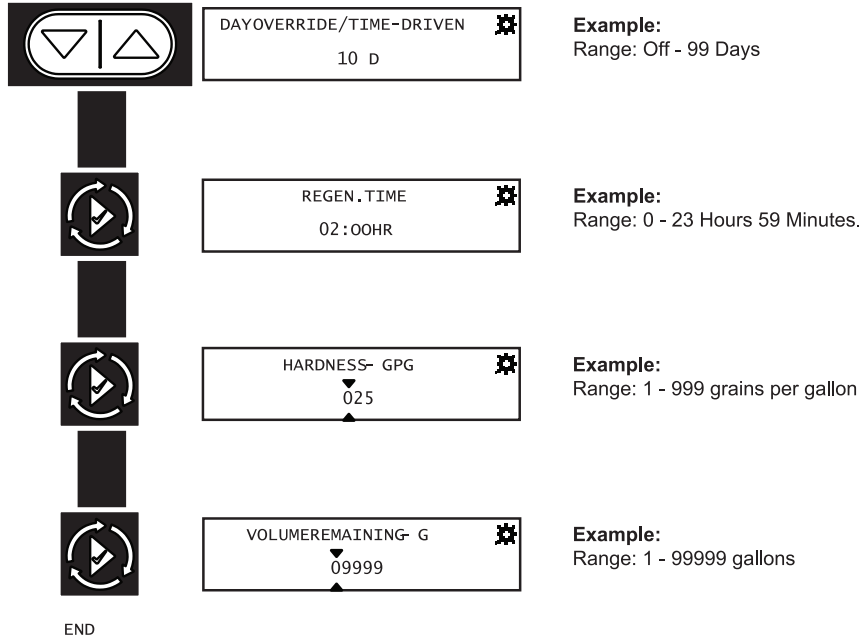

### 1. Enter User Mode

Press and hold the Up and Down buttons for 3 seconds.

### 2. Set Regeneration Day Override/Time Driven

To turn on and set the days, press the Up or Down button. Range is OFF to 99 days. Press the Extra Cycle button to proceed to the next step.

### 3. Set Regeneration Time

Press the Up and Down buttons to change the time value. Holding a button down will speed through the setting. Press the Extra Cycle button to proceed to the next step.

### 4. Set Feed Water Hardness

Press the Up and Down buttons to change the value of the numbers. Press the Extra Cycle button to proceed to the next number. Range is 0-999 gpg. After the third number is entered, pressing the Extra Cycle button will continue to the next step.

**NOTE: Only displayed when a metered option is chosen under System Type.**

### 5. Set Volume Remaining

Press the Up and Down buttons to change the value of the numbers. Press the Extra Cycle button to proceed to the next number. Range is 0-99,999 gallons. After the last number is entered, pressing the Extra Cycle button will end User Mode.

To exit user mode, progress through all available values, or press and hold the Left button at anytime, or after 5 minutes of inactivity the timer will return to normal operation automatically.

### 6. End of User Programming Mode

# MGT 2" 60M-600M NXT2 TWIN ALTERNATING OPERATION

---

## BATCH SIZE CALCULATION

Batch size is the term used for the amount of water being softened by the water softener between regenerations. The NXT2 controller calculates this value automatically based on the values in the program. This is a simple calculation provided two pieces of information are known:

Capacity of the water softener in grains (gr.)  
(i.e. MGT-300 has 300,000 grains capacity per tank).  
Hardness of the raw water being treated by the water softener.

## BATCH SIZE EQUATION:

$$\text{Batch Size} = \frac{\text{Grain Capacity of Softener}}{\text{Hardness of Water (grains per gallon)}}$$

## SAMPLE CALCULATION

### **Assume:**

Unit is a model MGT-300 softener  
The hardness of the water was measured to be 20 grains per gallon

Using our equation take  $300,000 \div 20 = 15,000$  gallons.  
10% Safety factor - reserve capacity = 1,500 gallons.  
 $15,000 \text{ gallons} - 1,500 \text{ gallons} = 13,500 \text{ gallons (batch size)}$

For immediate regeneration type meter control the meter setting would be at 15,000 gallons. Commonly this value is adjusted to 90 percent of the actual value (in this example 13,500 gallons) to assure not over-running the softener.

### **NOTE:**

For meter delayed options, the batch size is determined as in our example, except an additional amount of gallons must be accounted for and deducted from the total to allow soft water to be available until the softener regenerates at the selected delay time of day or night. This compensation is necessary since the meter will indicate regeneration required time prior to the set delay time. This can be accomplished on the NXT2 timer by increasing the safety factor in the **Master Programming** mode.

# MGT 2" 60M-600M NXT2 TWIN ALTERNATING OPERATION

## DIAGNOSTIC MODE FLOW CHART

### Entering Diagnostic Mode:

1. Press and hold the Left button to enter Diagnostic Programming mode.
2. To navigate, press the Extra Cycle button to advance to the next value. Press the Left button to retreat to the previous value.
3. To reset/clear a value (such as Totalizer or Error Log), while on the value, press and hold the Up and Down buttons simultaneously.
5. After progressing through all available values, the timer will return to Normal operation.
6. To exit diagnostic mode, press and hold the Left button at anytime or after 5 minutes of inactivity the timer will return to normal operation automatically.
7. Depending on the current controller programming, certain values may not be able to be viewed or set.
8. The timer will display local information, not system information.
9. In the event of a regeneration occurring while displaying diagnostics, the regeneration step and time remaining will be displayed. When regeneration has been completed, the display will return to the main screen.





# MGT 2" 60M-600M NXT2 TWIN ALTERNATING OPERATION

## MASTER PROGRAMMING MODE FLOW CHART

**NOTE:** Depending on current option settings, some displays cannot be viewed or set.

### Master Programming Mode:

1. Press and hold the Left and Down buttons simultaneously for 3 seconds to enter Master Programming mode.
2. To navigate, press the Extra Cycle button to advance to the next value. Press the Left button to retreat to the previous value.
3. Where applicable, use the Down and Up buttons to adjust a value as desired. When entering data into text fields (such as Assistance Name) or numerical fields (such as Hardness), press the Extra Cycle button to advance to the next character/digit and press the Left button to retreat to the previous character/digit. Proceed through all available characters/digits to advance to the next value.
4. To reset/clear a value (such as Assistance Name), while on the value, press and hold the Down and Up buttons simultaneously for 5 seconds.
5. To exit master programming mode, progress through all available values or after 5 minutes of inactivity the timer will exit automatically. To exit master programming without saving changes, press the Left button until you return to the service screen.
6. Depending on the current controller programming, certain values may not be able to be viewed or set.
7. The timer will display local information, not system information.
8. In the event of a regeneration occurring while displaying master programming, the regeneration step and time remaining will be displayed. When regeneration has been completed, the display will return to the main screen.
9. If any values are changed, make sure Push Settings is set to ON so the values are pushed to the other unit(s).



**Example:**  
On: View settings without the ability to alter settings.  
Off: User has ability to alter settings.



**Example:**  
English, Francais, Duetsch, Italiano, Espanol, Nederlandse, Portugues



**Example:**  
12 characters maximum.



**Example:**  
12 characters maximum.



**Example:**  
14 characters maximum.

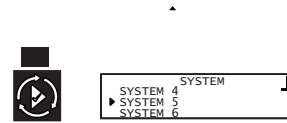

**Example:**  
4, 5, 6, 7, 8, 9, 14

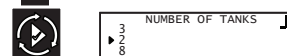

**Example:**  
2, 3, 4, 5, 6, 7, 8



**Example:**  
Trip Points only available/visible when System Type 14 is selected.

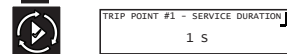

**Example:**  
Range: 1-90 seconds

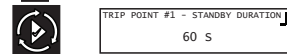

**Example:**  
Range: 60-300 seconds

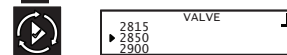

**Example:**  
2510, 2750, 2815, 2900, 3150, 3900



**Example:**  
Upflow  
Downflow  
Filter

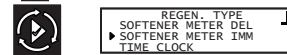

**Example:**  
Softener Meter Delayed  
Softener Meter Immediate  
Time Clock  
Day of the Week.



**Example:**  
Metric  
US

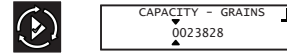

**Example:**  
Range: 0-9,999,999 grains



**Example:**  
Range: 0-199 GPG



**Example:**  
Fixed Volume  
Weekly Reserve  
Variable Reserve  
Fixed %



**Example:**  
Off, Immediate, Delayed

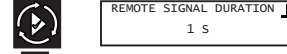

**Example:**  
Range:  
1-90 seconds (Service)  
60-300 seconds (Standby)



**Example:**  
Range: Off - 99 Days



**Example:**  
Range: 0 - 23 Hours 59 Minutes.

# MGT 2" 60M-600M NXT2 TWIN ALTERNATING OPERATION

## MASTER PROGRAMMING MODE FLOW CHART

- 

LOCK WINDOW #1  
 ON  
 OFF

**Example:**  
Start Lock Window  
End Lock Window
- 

BACKWASH  
 10 M

**Example:**  
Range: 0 - 240 M
- 

DRAW  
 60 M

**Example:**  
Range: 0 - 240 M
- 

RAPID RINSE  
 10 M

**Example:**  
Range: 0 - 240 M
- 

TANK REFILL  
 12 M

**Example:**  
Range: 0 - 240 M
- 

PAUSE  
 0 M

**Example:**  
Range: 0 - 240 M
- 

METER TYPE  
 0.75" TURBINE  
 1.00" PADDLE  
 1.00" TURBINE

**Example:**  
Paddle (0.75", 1", 1.5", 2", 3")  
Turbine (0.75", 1.25", 1.5")  
Generic
- 

CONTINUOUS FLOW DETECT  
 ON  
 OFF

**Example:**  
Range: 0.1 to 999.9 gpm/Lpm
- 

AUXILIARY 1  
 STANDBY  
 OFF  
 ALARM BASED

**Example:**  
Off, Alarm Based, Cycle Based, Time Based,  
Volume Based, Standby
- 

AUXILIARY 2  
 STANDBY  
 OFF  
 ALARM BASED

**Example:**  
Off, Alarm Based, Cycle Based, Time Based,  
Volume Based, Standby
- 

PUSH SETTINGS  
 OFF  
 ON
- 

SAVE AS NON-FACTORY  
 ON  
 OFF
- 

LOCK SETTINGS  
 TIME BASED  
 OFF  
 DELAYED

**Example:**  
Off, Delayed, Enter Code, Time Based

END

**K-FACTOR TABLE - SIGNET 2536**  
(Pulses per Gallon)

PIPE SIZE (inches)	GENERIC FLOW METER SETTINGS		
	TEE GALVANIZED	TEE PVC	SADDLE IRON
1	213	352	
1-1/4	128	177	
1-1/2	94	118	
2	59	67	54
2-1/2		43	38
3		27	23

**AUTO TURBINE METER**

METER SIZE	K-FACTOR
1	65
2	15

**CLACK METER**

METER SIZE	K-FACTOR
1-1/2	37
2	20
3	8

# MGT 2” 60M–600M NXT2 TWIN ALTERNATING OPERATION

## MASTER PROGRAMMING - TWIN ALTERNATING (SYSTEM 7)

STEP	FACTORY SETTING	RANGE
SETTINGS REVIEW	OFF	On-Off
LANGUAGE	ENGLISH	English, Francais, Deutsch, Italiano, Espanol, Nederlands, Portugues
ASSISTANCE NAME 1	ENTERED BY DEALER	
ASSISTANCE NAME 2	ENTERED BY DEALER	
ASSISTANCE PHONE	ENTERED BY DEALER	
SYSTEM	System 7 (2 Units) Alternating	System 4 (Single Unit) System 5 (2-8 Units) Parallel Interlock System 6 (2-8 Units) Parallel Series Regeneration System 7 (2 Units) Alternating (I) System 8 (2 Units) Alternating (D) System 9 (2-8 Units) Alternating with Stanby Uni System 14 (2-8 Units) Demand Recall
VALVE	2900	2815, 2510, 2750, 2850, 2900, 3150, 3900
REGEN. FLOW	Downflow	Filter Downflow
UNITS	US	US, Metric
CAPACITY - GRAINS*	see data table*	0-9,999,999 Grains
HARDNESS - GPG	ENTERED BY DEALER	0-199 gpg
REMOTE REGENERATION	Off	Off Delayed Immediate
DAY OVERRIDE/TIME DRIVEN	7	Off - 99 Days
REGEN. TIME	02:00AM	Any Time
LOCK WINDOW #1	Off	Off, On
LOCK WINDOW #2	Off	Off, On
BACKWASH	10 M	0-240 Mins
DRAW	60 M	0-240 Mins
RAPID RINSE	10 M	0-240 Mins
REFILL*	see data table*	0-240 Mins
PAUSE	0 M	0-240 Mins
METER TYPE*	see data table*	Generic Paddle (0.75", 1.00", 1.50", 2.00", 3.00") Turbine (0.75", 1.00", 1.25", 1.50")
CONTINUOUS FLOW DETECT	Off	On, Off
AUXILIARY 1	Off	Standby, Off, Alarm Based, Cycle Based, Time Based, Volume Based
AUXILIARY 2	Off	Standby, Off, Alarm Based, Cycle Based, Time Based, Volume Based
PUSH SETTINGS <sup>1</sup>	On	On, Off
SAVE AS NON-FACTORY <sup>2</sup>	On	On, Off
LOCK SETTINGS	Off	Time Based, Off, Delayed, Enter Code

\* For settings with an asterisk, consult the data table on page 5.

<sup>1</sup> Use PUSH SETTINGS to push the programming settings to the other unit. You only have to program one unit.

<sup>2</sup> Use "SAVE AS NON-FACTORY" to save all the programmed settings. When resetting the board, you can choose to reset to factory default settings or the non-factory settings.

# MGT 2" 60M-600M NXT2 TWIN ALTERNATING OPERATION

## SERVICE POSITION

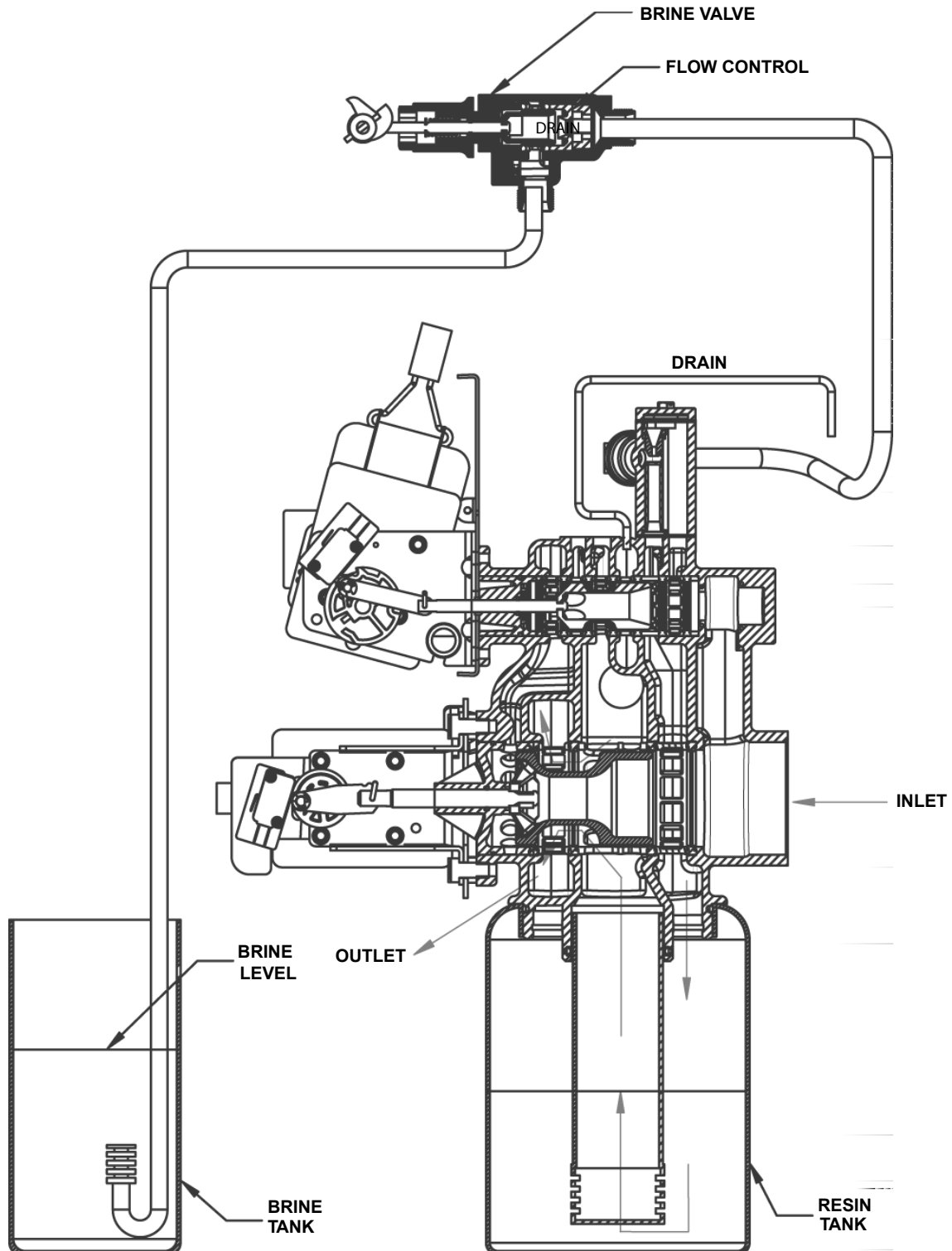

Hard water enters unit at valve inlet and flows down thru the mineral in the mineral tank. Conditioned water enters center tube thru the bottom distributor — then flows up thru the center tube — around the piston and out the side outlet of the valve.

# MGT 2" 60M-600M NXT2 TWIN ALTERNATING OPERATION

## BACKWASH POSITION

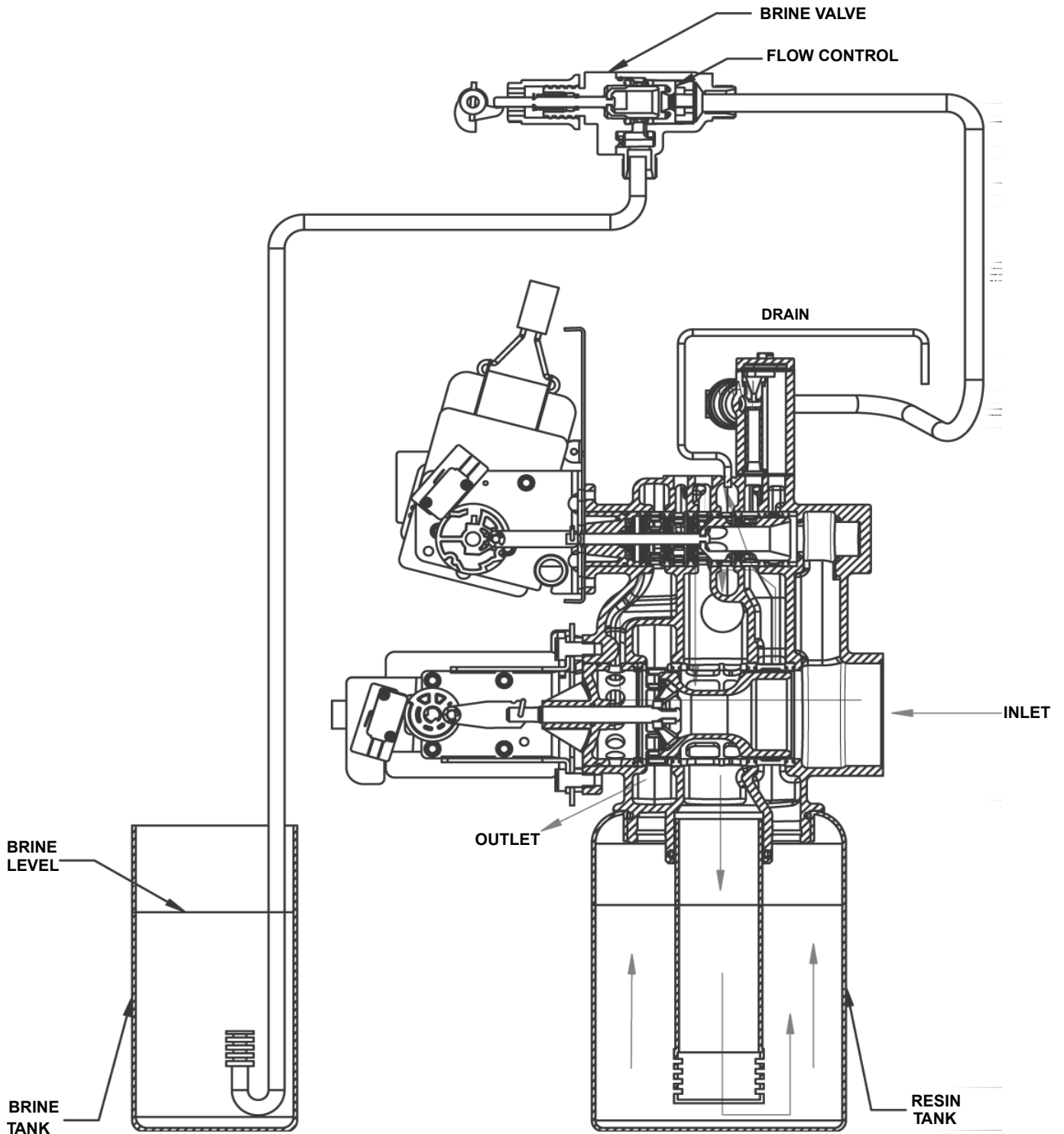

Hard water enters unit at valve inlet — flows to the front passage and up through the front passage to regenerating valve — down the center tube — thru the bottom distributor and up thru the mineral — around the piston and out the drain line. If optional no hard water by pass piston is used water flow to outlet is prevented by an extended section of the service piston which closes the outlet port from by pass water until the end of rapid rinse.

# MGT 2" 60M-600M NXT2 TWIN ALTERNATING OPERATION

## BRINE POSITION

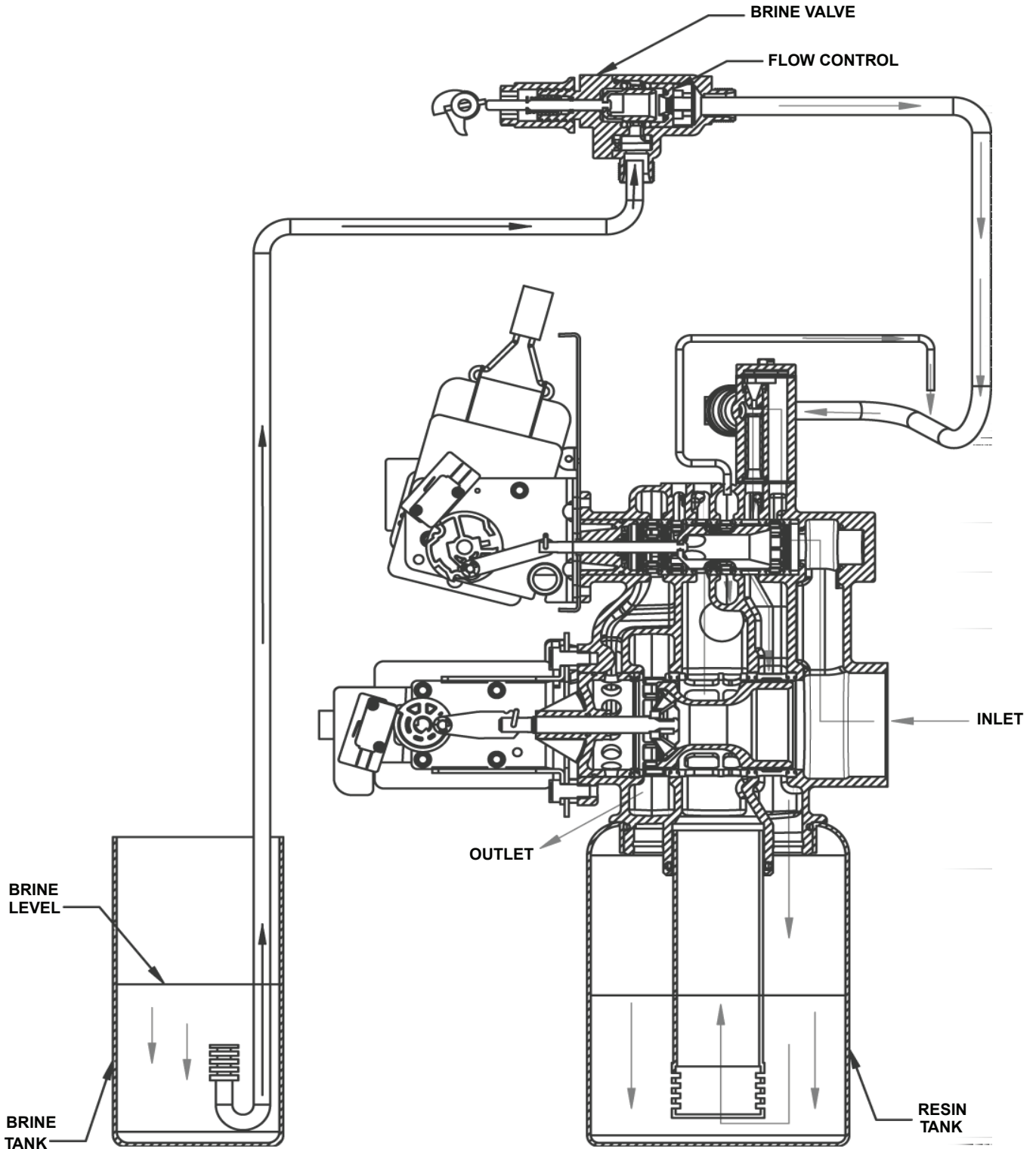

Hard water enters unit at valve inlet — flows up into injector housing and down thru nozzle and orifice to draw brine from the brine tank — brine flows down thru mineral and enters the center tube thru bottom distributor — flows up thru center tube — around the piston and out thru the drain line.

# MGT 2" 60M-600M NXT2 TWIN ALTERNATING OPERATION

## SLOW RINSE POSITION

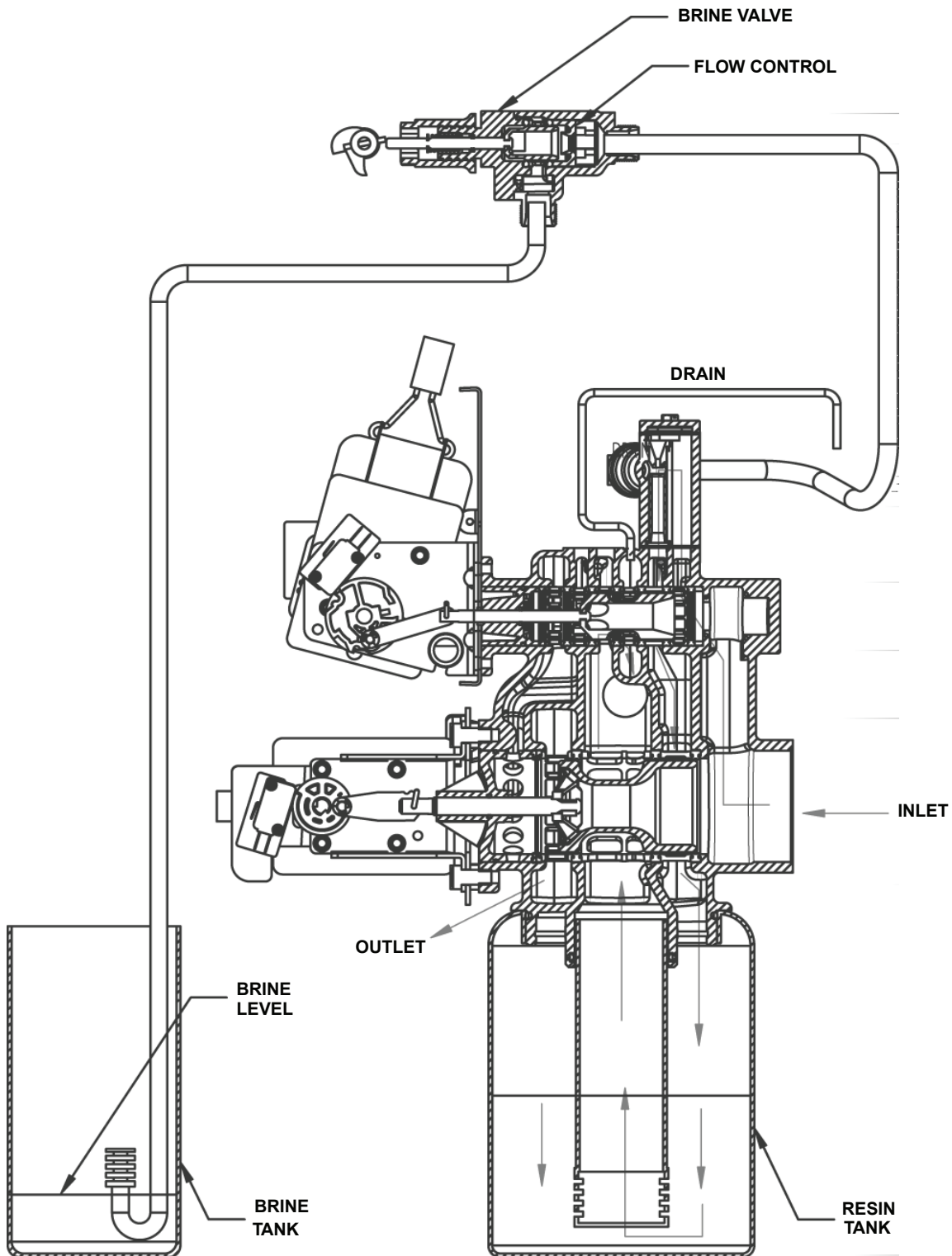

Hard water enters unit at valve inlet — flows up into injector housing and down thru nozzle and orifice — around the piston — down thru mineral — enters center tube thru bottom distributor — flows up thru center tube — around piston and out thru the drain line.

# MGT 2" 60M-600M NXT2 TWIN ALTERNATING OPERATION

## RAPID RINSE POSITION

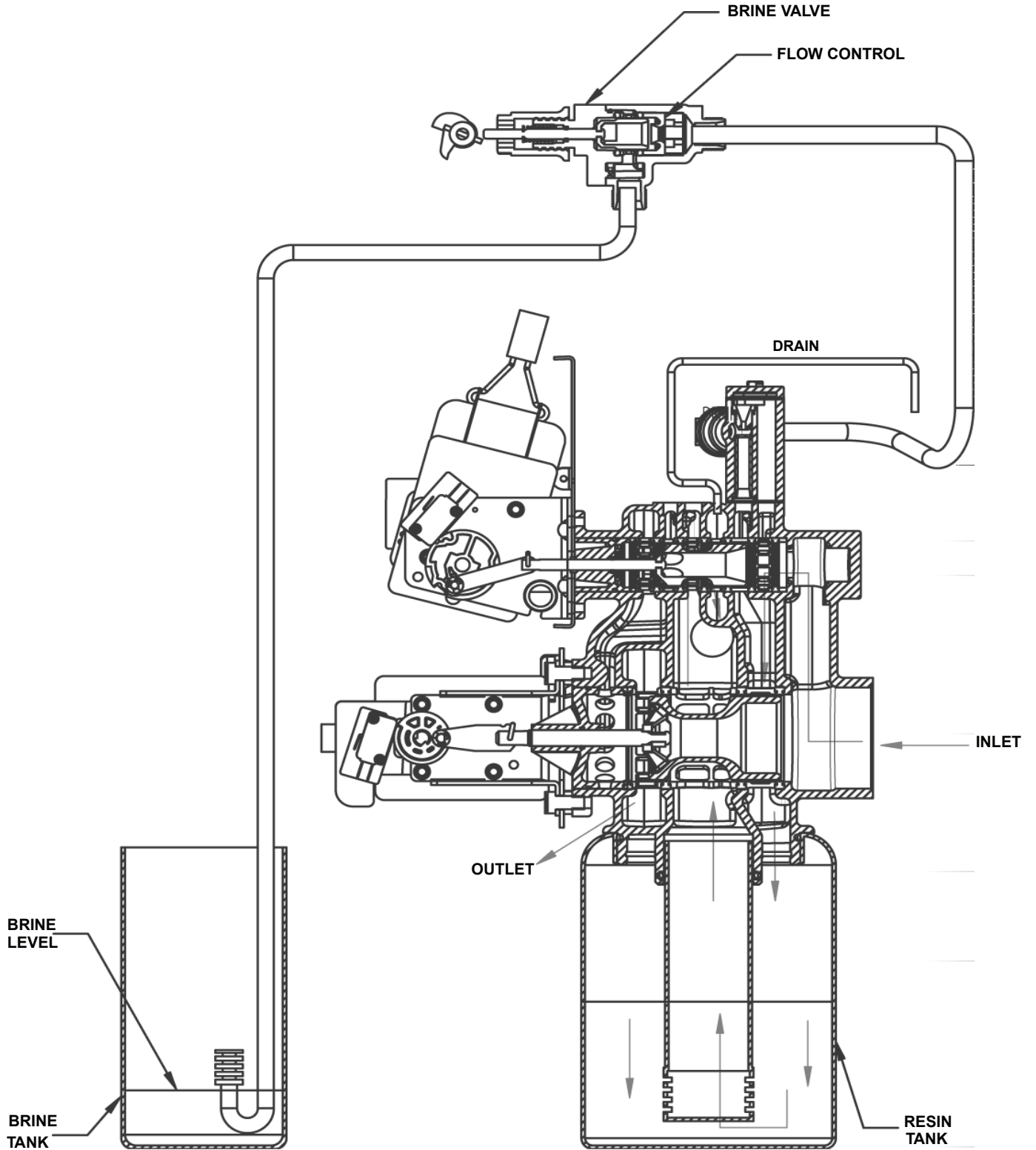

Hard water flows thru the regenerating valve directly down thru the mineral into the bottom distributor and up thru the center tube — around the piston and out the drain line.



# MGT 2" 60M-600M NXT2 TWIN ALTERNATING OPERATION

## BRINE TANK FILL POSITION

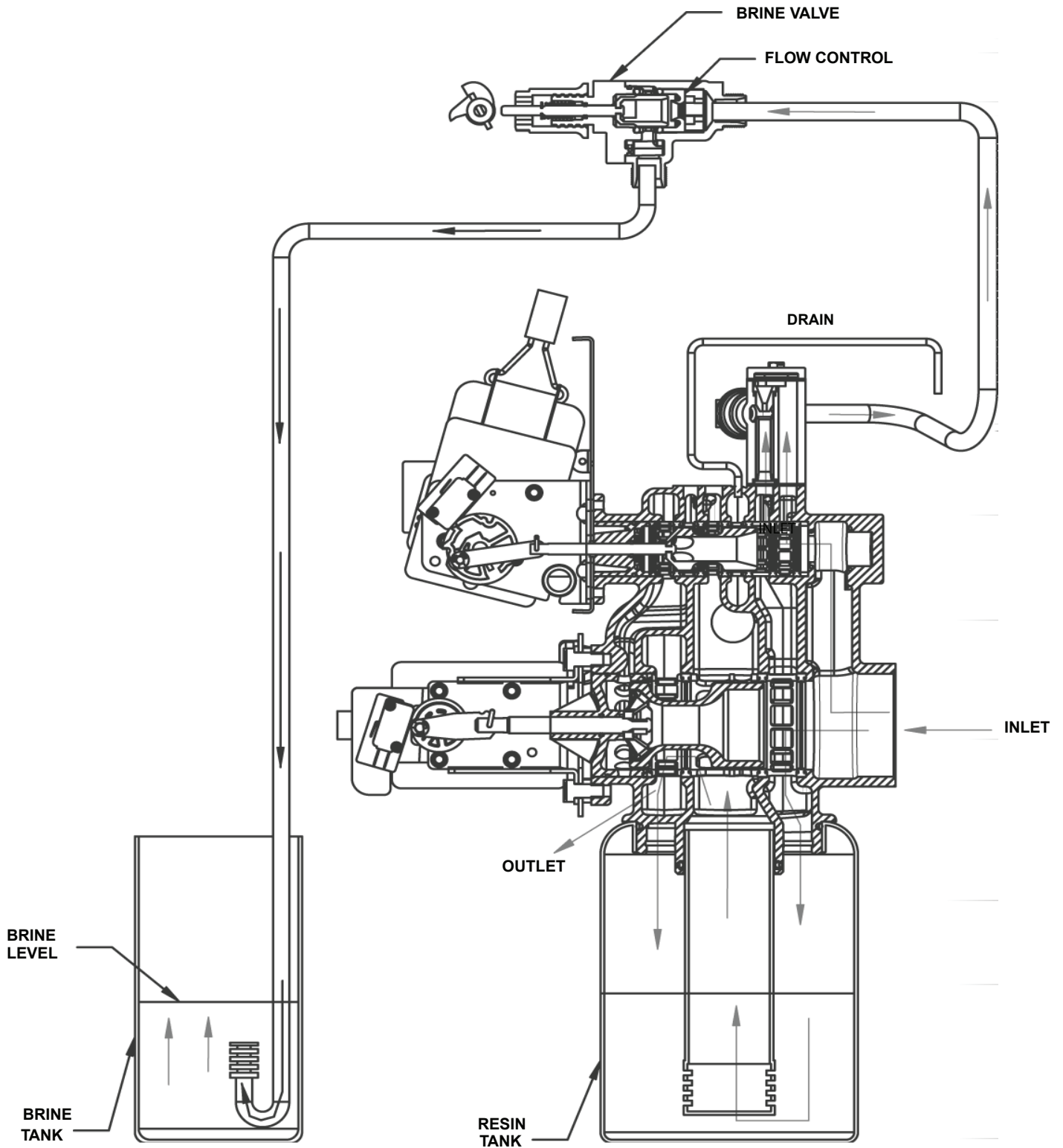

Hard water flows thru the service valve and down thru the mineral. Conditioned water enters the bottom distributor — flows up the center tube around the piston to the outlet. Hard water flows to the regenerating valve thru the injector housing and brine valve to fill the brine tank.

# MGT 2" 60M-600M NXT2 TWIN ALTERNATING MAINTENANCE

## NXT2 WIRING DIAGRAM

\*WIRING DIAGRAMS ARE REFERENCE ONLY. ALL WIRING SHOULD BE DONE BY A CERTIFIED ELECTRICIAN AND MEET ALL ELECTRICAL CODES.

	FLOW METER (FM) WIRING		
	GROUND (-)	POWER (+)	SIGNAL
FLECK	BLACK	RED	GREEN
SIGNET	SHIELD	BLACK	RED
CLACK	BLACK	RED	WHITE
AUTOTROL	CLEAR	RED	BLACK

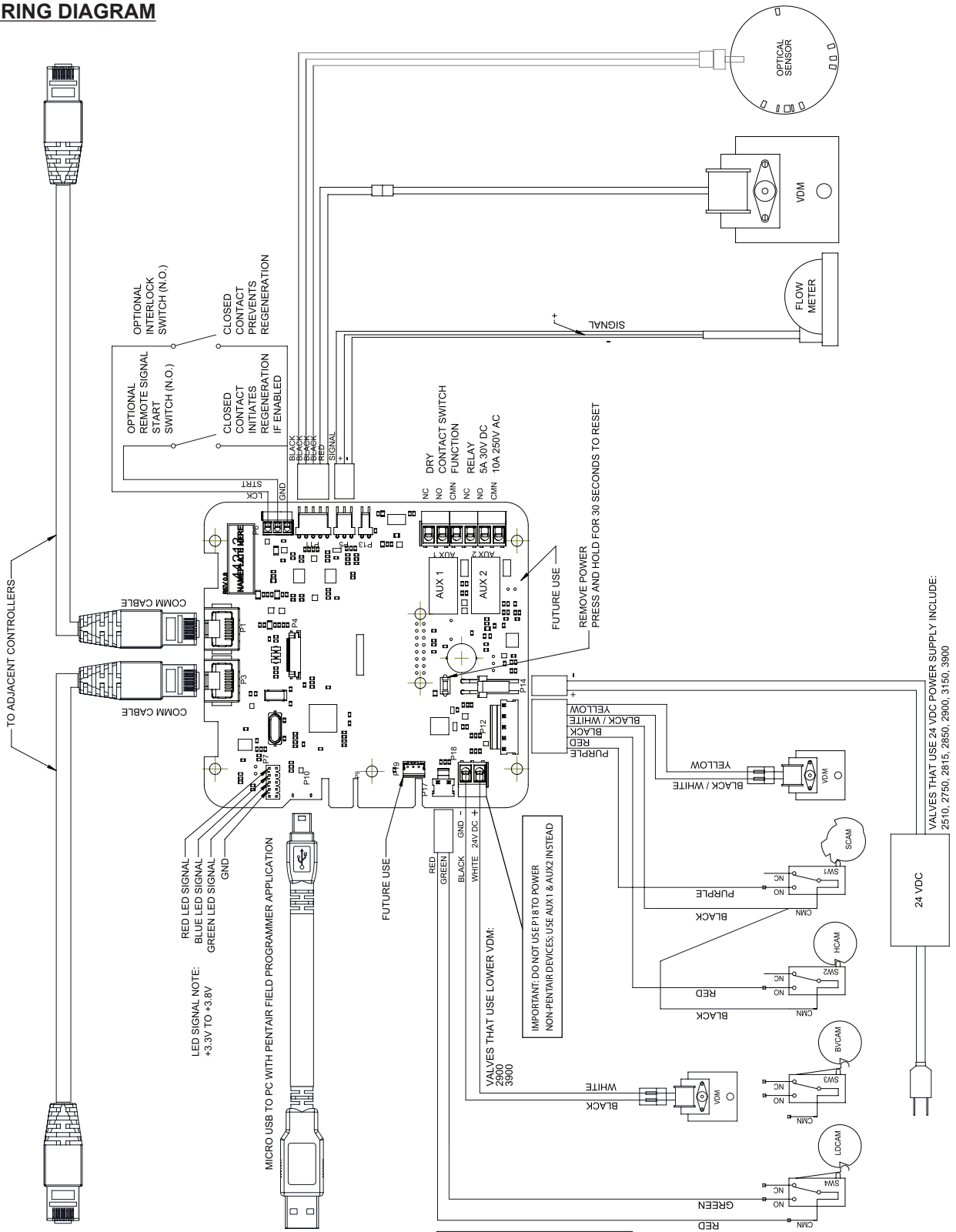

- 1/CAM- BRINE VALVE CAM
- M/- COMMON
- ND- GROUND
- CA/VALVE-HOMING CAM
- 2/CAM- LOWER DRIVE CAM
- 3/CAM- LOWER DRIVE LOCK
- 2/R-REMOTE REGEN LOCK
- C- NORMALLY CLOSED
- O- NORMALLY OPEN
- CAM/- VALVE STEP CAM
- TR1- REMOTE REGEN START
- W1- VALVE HOMING SWITCH
- W2- VALVE STEP SWITCH
- W3- BRINE CAM SWITCH
- W4- LOWER DRIVE SWITCH
- DM- VALVE DRIVE MOTOR

VALVES THAT USE 24 VDC POWER SUPPLY INCLUDE:  
2510, 2750, 2815, 2850, 2900, 3150, 3900



# MGT 2" 60M-600M NXT2 TWIN ALTERNATING MAINTENANCE

## 2900 POWERHEAD PARTS LIST

Item No.	Quantity	Part No.	Description
1	1	18697-15	backplate, hinged
2	1	60219-02	cover assy, environmental, black
3	1	60160-10	drive cam assy, stf, black
4	1	10909	pin, link
5	2	14923	screw, pan hd mach, 4-40 x 1
6	5	10302	insulator, limit switch
7	3	10218	switch, micro
8	2	10231	screw, slot hex, 1/4 - 20 x 1/2
9	1	41544	motor, drive, 24V, 50/60 Hz
10	1	12777	cam, shut-off valve
11	2	10338	pin, roll, 3/32 x 7/8
12	1	transformer, US, 120V, 24V, 108VA	See Service Assemblies on page 45.
		transformer, euro, 230V/24V 108VA	See Service Assemblies on page 45.
		transformer, aust, 230V/24V, 108VA	See Service Assemblies on page 45.
13	1	19691	plug, .750 dia, recessed, black
14	2	19800	plug, .140 dia, white
15	1	15806	plug, hole, heyco #2693
16	9	19801	plug, .190 dia, white, heyco #0307
17	1	17967	fitting assy, liquid tight, blk
18	1	10896	switch, micro
19	4	11805	screw, rd hd, 4-40 x 5/8 type 1
20	1	40943	wire harness, lower drive, w/molded strain relief
21	1	13547	strain relief, flat cord, heyco #30-1
22	1	19121	meter cable assy, 3200NT
		19121-08	meter cable assy, NT, 35" w/connector
		19121-09	meter cable assy, NT, 99.5" w/connector
		19121-10	meter cable assy, NT, 303.5" w/connector
23	1	14202-01	screw, hex wsh mach, 8-32 x 5/16
24	1	40941	wire harness, upper drive
25	1	17421	plug, 1.20 hole, heyco #2733
26	2	41581	plug, hole, .125 dia, white
27	1	60217-02	cover assy, 2900, lower, black, environmental
28	1	18626	spacer, indicator
29	1	18746	bearing, connecting rod
30	2	11224	screw, hex hd 5/16 - 18 x 5/8, SS
31	1	10250	ring, retaining
32	7	10872	screw, hex wsh, 8-32 x 17/64
33	1	18709	backplate, lower
34	1	11381	pin, roll, 2900/3900
35	1	14759	link, piston rod
36	1	14769	bracket, motor, 2900
37	1	14775	cam, drive, 2900
38	2	16346	nut, hex, jam, 5/16-18, 18-8-SS
39	1	18725	indicator, service/standby
40	1	40388	motor, drive, 24V, 50/60Hz, SP
41	1	14813	pin, spring, connecting rod
42	1	41102	label, 3200NT, ground
43	1	10269	nut, jam, 3/4 - 16
44	1	10712	fitting, brine valve
45	1	41047	kit, communication cable
46	1	62115	NXT2 Timer & Bracket Assy

NOTE: For all other service part numbers, see the Service Manual that accompanies the control valve.

# MGT 2" 60M-600M NXT2 TWIN ALTERNATING MAINTENANCE

## NXT2 TIMER ASSEMBLY (2510, 2750, 2850, 2900, 3150 & 3900 VALVES)

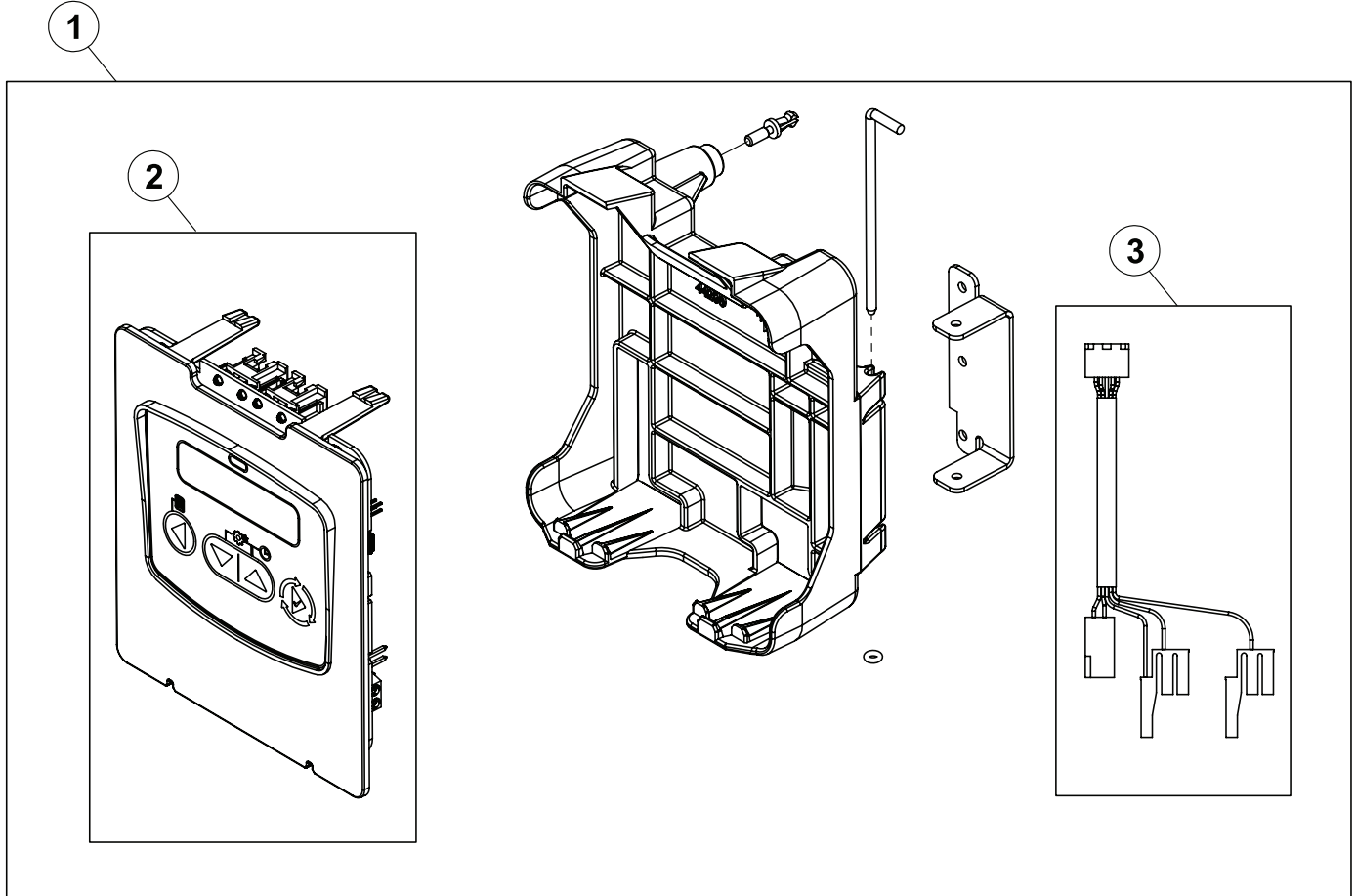

Item No.	QTY	Part No.	Description
1	1	62115	Timer Assy, NXT2 Service Assemblies
2	1	62120	Control Panel Assy, NXT2, Programmed
3	1	40941	Wire Harness, Upper Drive

# MGT 2" 60M-600M NXT2 TWIN ALTERNATING MAINTENANCE

## 2900 CONTROL VALVE BODY

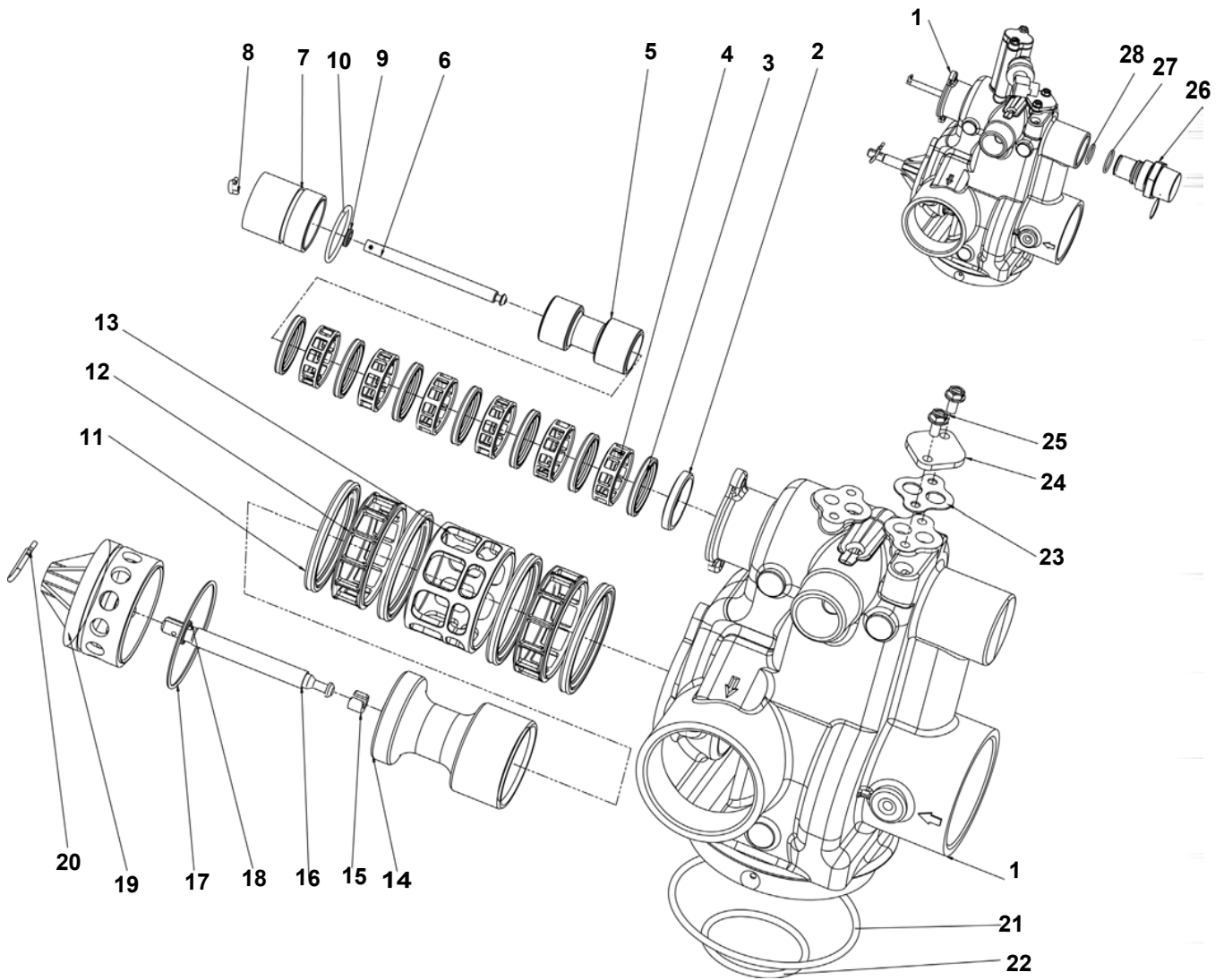

# MGT 2" 60M-600M NXT2 TWIN ALTERNATING MAINTENANCE

---

## 2900 CONTROL VALVE PARTS LIST

Item No.	Quantity	Part No.	Description
1	1	41428	Valve Body, 2900 CPI, Machined
1	-	41428-xx	Valve Body, 2900 CPI, Machined, W/Soft Water Adapt
2	1	10757	Spacer, End
3	7	10545	Seal, Piston
4	6	11451	Spacer, 1 2 Hole
5	1	41425	Piston, 2900 CPI, Upper, D/F
5	-	14451	Piston, 2750
6	1	14309	Retainer, Piston Rod
7	1	41424	Rod, Piston
8	1	41131	End Plug
9	1	10909	Ppin, Connecting Rod Spring
10	1	10209	Quad Ring,-010
11	1	40078	O-ring, 28MM X 2MM
12	4	11720	Seal, Piston, 2900/3150
13	2	10369	Spacer, 2", 2900/3150
14	1	14753	Spacer, 2900
15	1	14757	Piston No HWBP 2900
16	1	14818	Ring, Piston Rod, Snap
17	1	14758	Piston Rod
18	1	14922	O-ring, -035
19	1	14926	Quad ring "O" ring-012
20	1	14813	Connecting Link Pin
21	1	13575	O-ring, -240
22	1	13577	O-ring, -226
23	1	14805	Gasket, Injector Body
24	1	11893	Cap, Injector, SS
25	2	15137	Screw, Hex Washer Head, #10 - 24 X 3/8
26	-	41448	Adapter, Softwater Regen, 2900
27	-	16924	O-ring, -018
28	-	19292	O-ring, -020

# MGT 2" 60M-600M NXT2 TWIN ALTERNATING MAINTENANCE

## 1600 BRINE SYSTEM

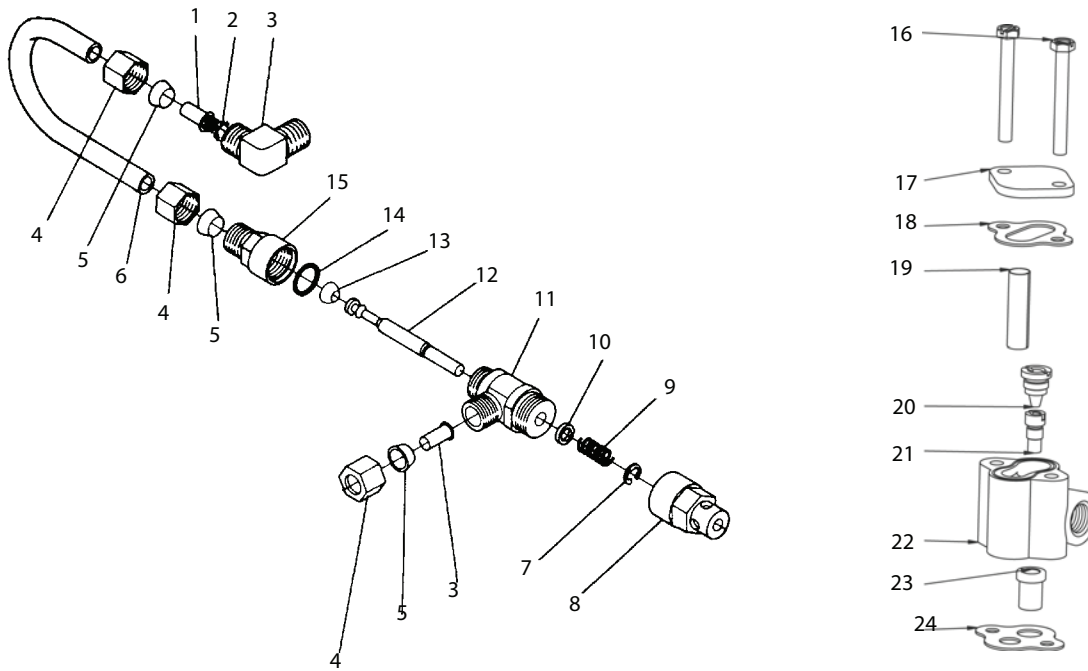

Item No.	Quantity	Part No.	Description
1	1	10328	90° Elbow - ¼ Pipe Thd. to 3/8" Tube
2	1	12767	Brine Line Screen
3	2	10332	Insert Sleeve 3/8" Tube
4	3	10329	Fitting Nut (3/8" Tube)
5	3	10330	Derlin Sleeve (3/8" Tube)
6	1	15221	Brine Valve Tube
7	1	10250	Retaining Ring
8	1	11749	Stem Guide
9	1	10249	Brine Valve Spring
10	1	12550	Quad Ring
11	1	12748	Brine Valve Body
12	1	12552	Brine Valve Stem
13	1	12626	Brine Valve Seat
14	1	11982	O-Ring
15	1	60020-25	BLFC.25GPM
		60020-50	BLFC .50 GPM
		60020-100	BLFC 1.0 GPM
16	2	10692	Screw, Slotted, Indented Hex Head, #10 - 24 X 5/6
17	1	11893	Cap, Injector, SS
18	1	10229	Gasket, Injector Body
19	1	10227	Screen, Injector
20	1	10913	Nozzle, Injector, Std
21	1	10914	Injector Throat, Std
22	1	17776	Body, Injector, 1600
23	1	16221	Disperser, Air
24	1	14805	Gasket, Injector Body



# MGT 2" 60M-600M NXT2 TWIN ALTERNATING MAINTENANCE

## 1700 BRINE SYSTEM ASSEMBLY

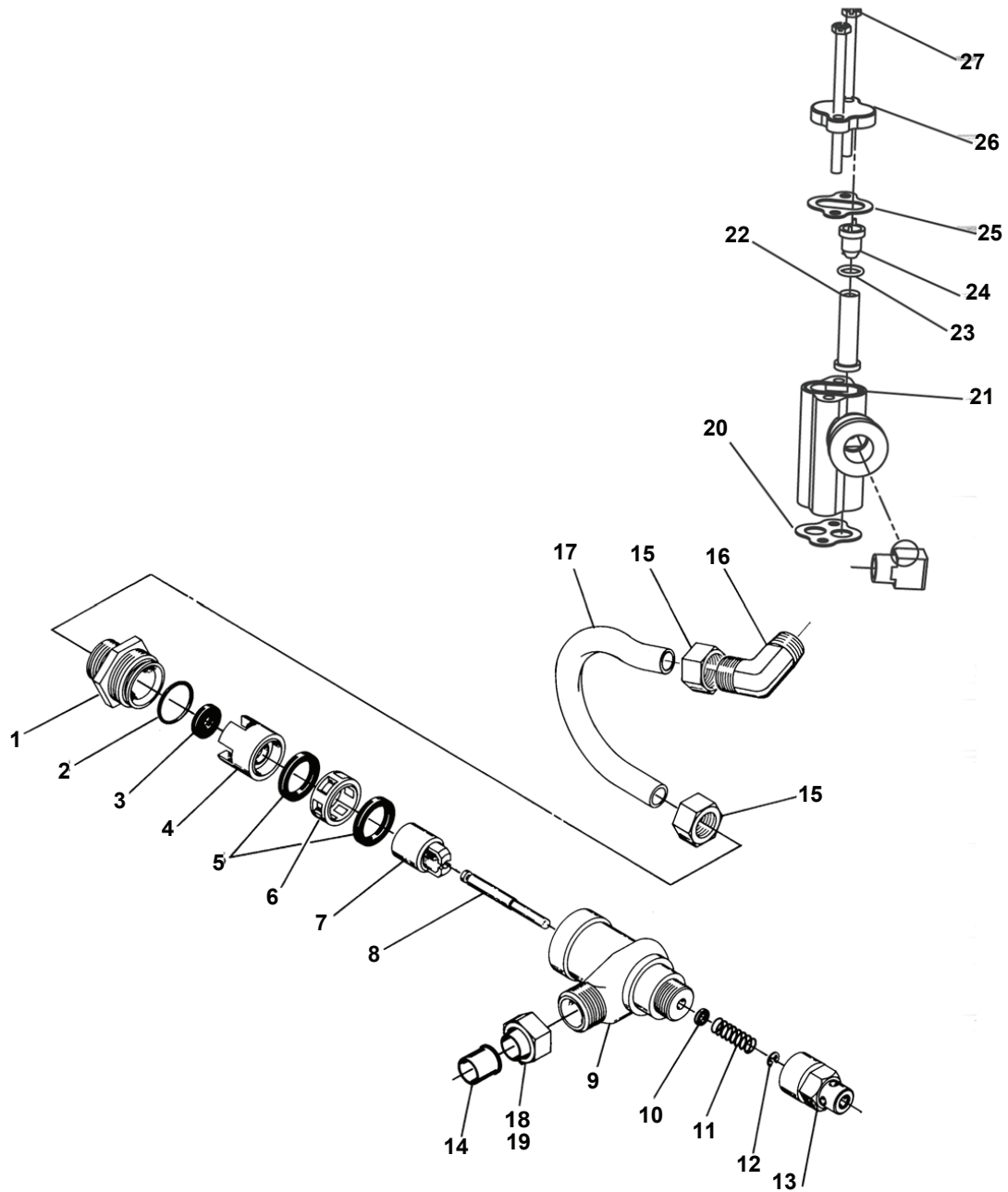

# MGT 2" 60M-600M NXT2 TWIN ALTERNATING MAINTENANCE

## 1700 BRINE SYSTEM PARTS LIST

Item No.	Quantity	Part No.	Description
1	1	14792	End Plug
2	1	13201	O-Ring - End Plug
3	1	12085	Flow Washer 1.2 GPM
		12086	Flow Washer 1.5 GPM
		12087	Flow Washer 2.0 GPM
		12088	Flow Washer 2.4 GPM
		12089	Flow Washer 3.0 GPM
		12090	Flow Washer 3.5 GPM
		12091	Flow Washer 4.0 GPM
		12092	Flow Washer 5.0 GPM
4	1	14785	Flow Control Retainer
5	2	14811	Piston Seals
6	1	14798	Spacer
7	1	14795	Brine Valve Piston
8	1	14797	Brine Valve Stem
9	1	14790	Brine Valve Body
10	1	12550	Quad Ring - Brine Stem
11	1	15310	Spring - Brine Valve
12	1	10250	Retaining Ring
13	1	15517	Stem Guide
14	1	15415	Insert
15	2	15414	Nut Ferrule 1/2"
16	1	15413	Elbow
17	1	15416	Brine Tube
18	2	16123	Tube Nut 1/2"
19	2	16124	Ferrule 1/2"
20	1	16974	Fitting, Brass, Female 3/4" x 3/4" Slip - Not Shown
21	1	11893	Injector Cover
22	1	10229	Injector Cover Gasket
23	1	17777	Injector Body
24	1	*14802	Injector Throat
25	1	*14801	Injector Nozzle
26	1	14803	Injector Screen
27	2	14804	Screw, Hex Head Mach, #10 - 24 X 2 3/4" 18-8 SS
		*Injector Throat	*Injector Nozzle
		Size	Color
		14802-03C	14801-03C #3C Yellow
		14802-04C	14801-04C #4C Green
		14802-05C	14801-05C #5C White
		14802-06C	14801-06C #6C Red
		14802-07C	14801-07C #7C Black

# MGT 2" 60M-600M NXT2 TWIN ALTERNATING MAINTENANCE

## 2" PLASTIC PADDLE METER

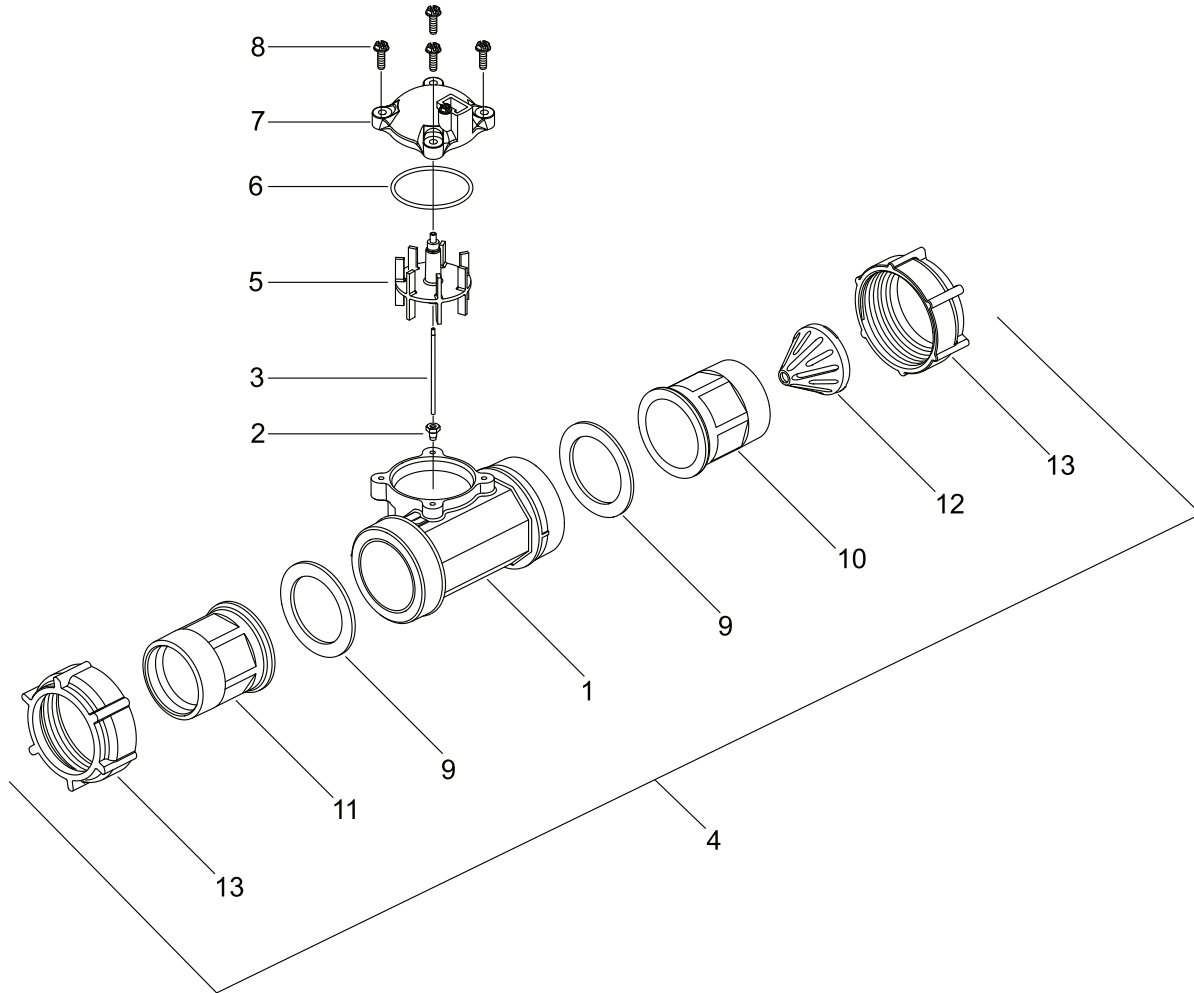

Item No.	Quantity	Part No.	Description
1	1	17689	Body, Meter, 2" Plastic w/Impeller Shaft Seat
2	1	15532	Seat, Impeller Shaft, Hex
3	1	15432	Shaft, Impeller, SS
4	1	60620	Meter Assembly, 2" Plastic, Std
		60621	Meter Assembly, 2" Plastic, Ext
		60625	Meter Assembly, 2" Plastic, Electronic
5	1	15374	Impeller Assy, 2" Meter
6	1	13847	O-Ring, -137, Std/560CD, Meter
7		14716	Meter Cap Assy, ET/NT
8	4	12473	Screw, Hex Wsh, 10-24 x 5/8 18-8 S.S.
9	2	40666	Seal, Face, 2", Plastic Meter
10	1	17987-001	Fitting, Nipple, 2", Plastic, NPT, Machined, Flow Straightener
		17987-101	Fitting, Nipple, 2", Plastic, BSP, Machined, Flow Straightener
11	1	17987-000	Fitting, Nipple, 2", Plastic, NPT
		17987-100	Fitting, Nipple, 2", Plastic, BSP
12	1	14680	Flow Straightener
13	2	17988	Nut, 2" Meter

# MGT 2" 60M-600M NXT2 TWIN ALTERNATING MAINTENANCE

## 2" STAINLESS STEEL METER ASSEMBLY

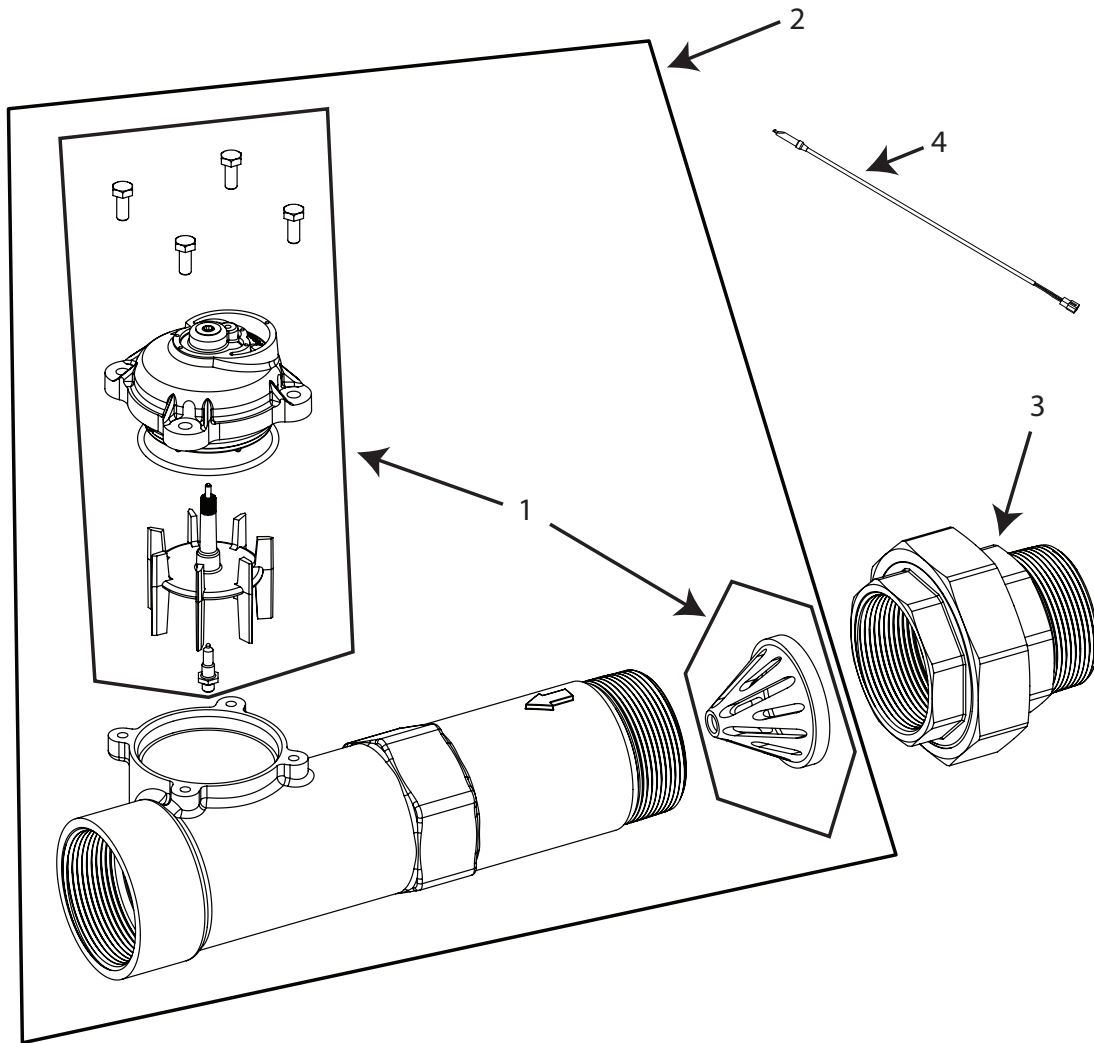

Item No.	QTY	Part No.	Description	Item No.	QTY	Part No.	Description
1.....	1.....	62048-01.....	Service Kit, 2 inch Meter, Standard Range	4.....	1.....	19791.....	Meter Cable Assembly,
1.....	1.....	62048-02.....	Service Kit, 2 inch Meter, Extended Range	.....	.....	19791-02.....	Meter Cable Assembly, 28 inch long with connector
2.....	1.....	61934-10.....	Meter Assy, 2 inch, Inline, Stainless Steel, NPT, Standard Range	.....	.....	19791-04.....	Meter Cable Assembly, 100 inch long with connector
1.....	1.....	61934-11.....	Meter Assy, 2 inch, Inline, Stainless Steel, NPT, Extended Range	.....	.....	19791-05.....	Meter Cable Assembly 304 inch long with connector
1.....	1.....	61934-20.....	Meter Assy, 2 inch, Inline, Stainless Steel, BSP, Standard Range	Not Shown (optional)			
1.....	1.....	61934-21.....	Meter Assy, 2 inch, Inline, Stainless Steel, BSP, Extended Range	1.....	1.....	62073.....	Meter Sleeve , 2 inch to 1-1/2 inch (optional)
3.....	1.....	44026.....	Union, 2 inch, NPT (Optional on models with electronic controls)				
1.....	1.....	44027.....	Union, 2 inch, BSP (Optional on models with electronic controls)				

# MGT 2" 60M-600M NXT2 TWIN ALTERNATING MAINTENANCE

## 2536 SIGNET FLOW SENSOR

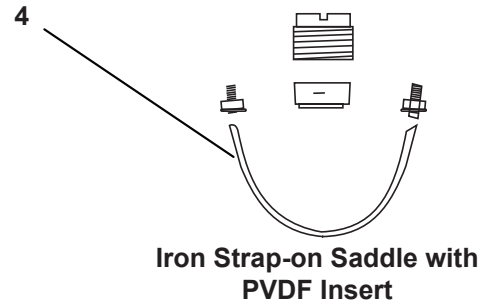
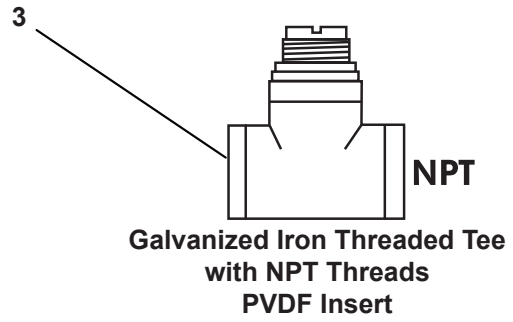
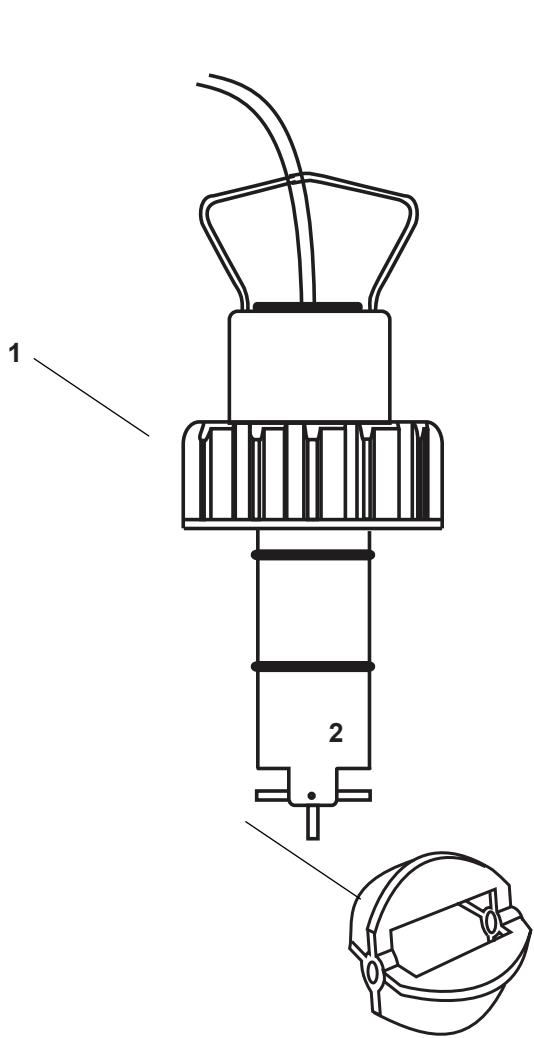

**K-FACTOR TABLE - SIGNET 2536**  
(Pulses per Gallon)

PIPE SIZE (inches)	GENERIC FLOW METER SETTINGS		
	TEE GALVANIZED	TEE PVC	SADDLE IRON
1	213	352	
1-1/4	128	177	
1-1/2	94	118	
2	59	67	54
2-1/2		43	38
3		27	23

ITEM NUMBER	PART NUMBER	DESCRIPTION
1	A2296001	Flow Sensor
2	A2456004	Rotor/Paddle
3	A2294012	Tee Install 1 Galv
	A2294002	Tee Install 1-1/4 Galv
	A2294003	Tee Install 1-1/2 Galv
	A2294004	Tee Install 2 Galv
4	A2295001	Saddle 2-1/2 Iron
	A2295002	Saddle 3 Iron

# MGT 2" 60M-600M NXT2 TWIN ALTERNATING MAINTENANCE

## AUTOTROL 2" TURBINE METER

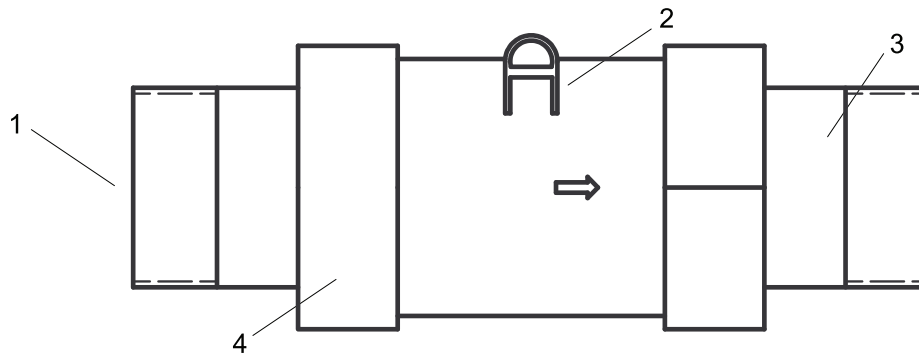

**K-FACTOR TABLE  
AUTO TURBINE METER**  
(Pulses per Gallon)

METER SIZE	K-FACTOR
1	65
2	15

ITEM NUMBER	PART NUMBER	DESCRIPTION
1	A2100019	2" Meter With Stainless Steel Adapter
	A2100004	2" Meter With Pvc Adapter
2	A2100005	2" Turbine Meter Body - Less Connections
3	A2100019	Adapter Meter 2" Npt Stainless Steel
	A2294002	Adapter Meter 2" Solvent Weld Pvc
4	A2095023	2" Galv. Nut
Not Shown	A2086013	Gasket
	A2325003	Cable Assembly 10'
	A2352030	Cable Assembly 25'

# MGT 2" 60M-600M NXT2 TWIN ALTERNATING MAINTENANCE

## CLACK 2" TURBINE METER

### V3050 WS2 2" Meter NPT Assembly and V3050BSPT WS2 2" Meter BSPT Assembly

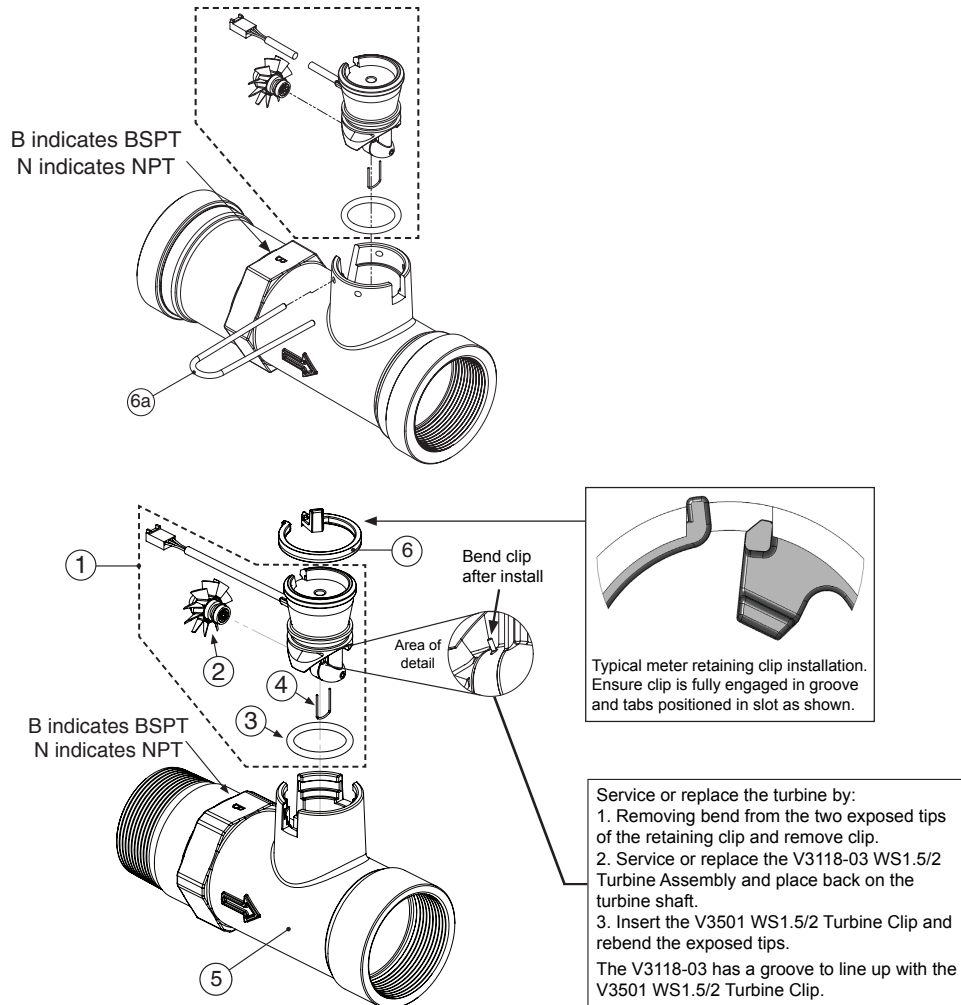

### K-FACTOR TABLE - CLACK METER

(Pulses per Gallon)

METER SIZE	K-FACTOR
1-1/2	37
2	20
3	8

ITEM NUMBER	PART NUMBER	DESCRIPTION	QUANTITY	CLACK PART NUMBER
1	A2360061	WS Remote Meter Asy 15 Ft Cord (includes V3118-03, V3501 and V3105)	1	V3221
2	A2100029	WS1.5/2 Turbine Asy	1	V3118-03
3	A2077178	O-Ring 215	1	V3105
4		WS1.5/2 Turbine Clip	1	V3501
5		WS2 Meter NPT Housing	1	V3222-01
		WS2 Meter BSPT Housing		V3222BSPT-01
6a	A2411018	WS2 Meter Clip	1	V3223
6b	A2411021	WS1.5/2/3 Meter Retaining Clip	1	V3632*
NOT SHOWN		WS2 Flow Straightener (located inside meter housing)	1	V3488

\* In 2008 a modification was made to Meter Housings to use V3632 WS1.5/2/3 Meter Retaining Clip. Do not use V3632 on old style housings which have holes through the castings to accept the U-shaped V3223 WS2 Meter Clip.

# MGT 2" 60M-600M NXT2 TWIN ALTERNATING MAINTENANCE

## BRINE SYSTEM - MGT 60M-90M

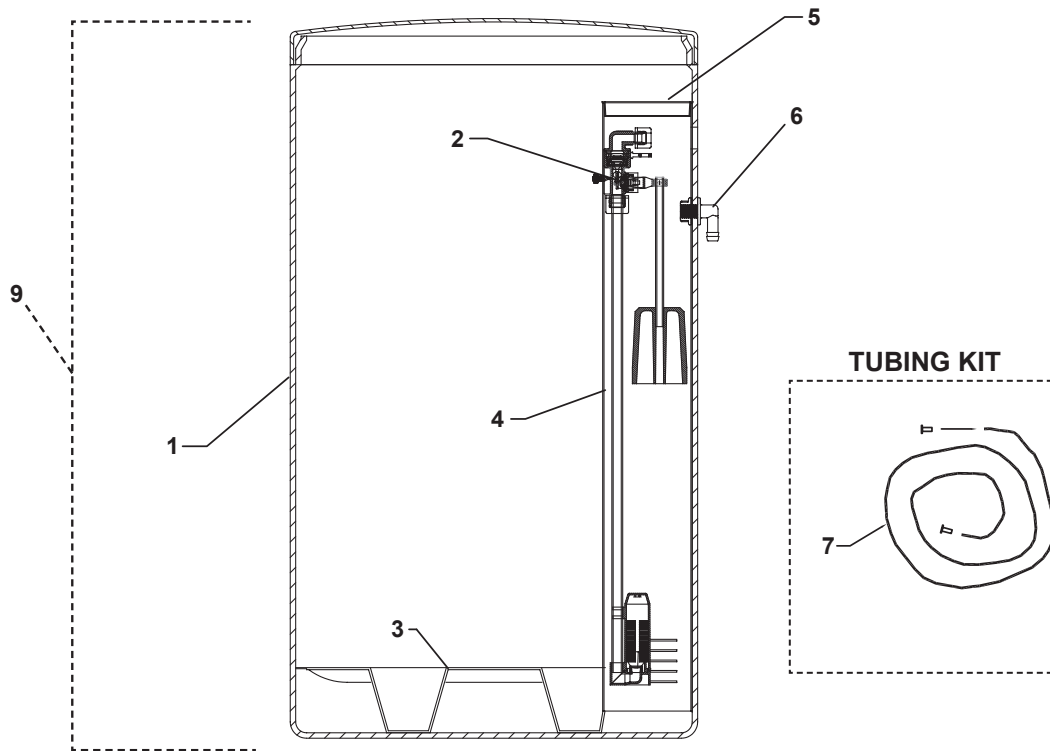

Item Number	Description	Part Number
1	Brine Tank 18"x40" Black Molded Cover - MGT 60 - 90M	A2042028
2	Brine Valve Assembly 474 w/ Aircheck - MGT 60M - 90M	B1179005
3	5" Grid Plate - Plastic - MGT 60M - 90M	A2284002
	6" Grid Extension - Plastic MGT 60M - 90M	A2215007
4	Slotted Brine Well - 4" x 36" - MGT 60M - 90M	A2071003
5	4" Brine Well Cap	A2072003
6	1/2" Overflow Elbow w/ Nut	A2250003
7	3/8" Tubing Kit	B1227012
8	Complete Brine Tank Assembly for MGT 60M - 90M	A2042064



# MGT 2" 60M-600M NXT2 TWIN ALTERNATING MAINTENANCE

## BRINE SYSTEM - MGT 120M-300M

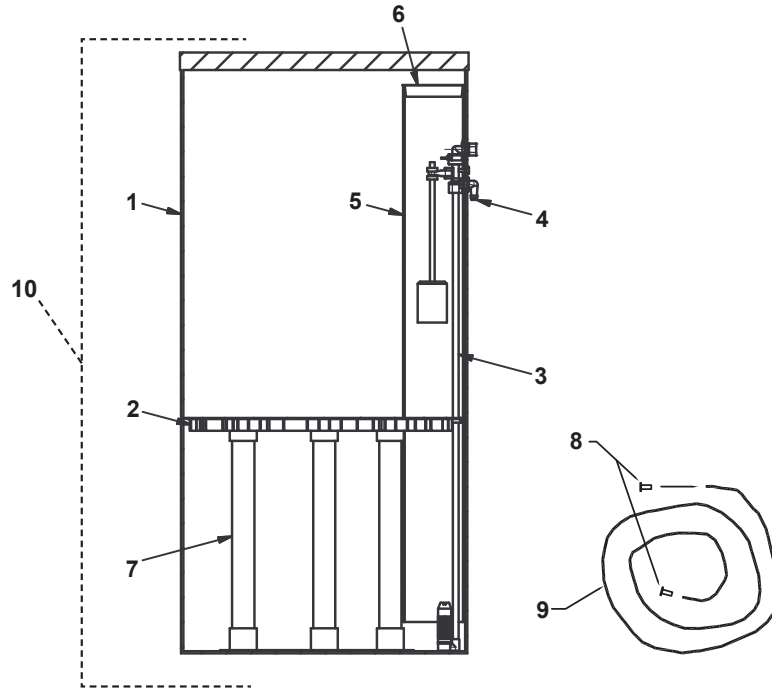

Item Number	Description	Part Number
1	Brine Tank 24" x 41" w/ Holes - MGT 120M	B1002039
	Brine Tank 24"x50" w/ Holes - MGT 150M-300M	B1002016
2	24" Diameter 5BW Plastic Grid Plate	A2284007
3	Brine Valve (474) for MGT 120	B1180014
	Brine Valve (474) for MGT 150	B1180015
	Brine Valve (474) for MGT 180	B1180016
	Brine Valve (474) for MGT 210	B1180017
	Brine Valve (474) for MGT 240	B1180018
	Brine Valve (474) for MGT 270	B1180019
	Brine Valve (474) for MGT 300	B1180020
4	1/2" Overflow Elbow w/ Nut	A2250003
5	5" x 46" Drilled Brine Well MGT 150M-300M	B1015008
	4" x 36" Drilled Brine Well (MGT-120)	B1015010
6	5" Red Cap plug MGT 150M-300M	A2072001
	Cap Brine Well 4 Inch (MGT-120)	A2072003
7	1-1/2" SDR or SCH40 DWV Pipe	A2275007
8	1/2" Poly Insert MGT 150M-300M	A2476001
	Insert 3/8 Tube Brass (MGT-120)	A2207018
9	1/2" x 3/8" Black Poly Tubing MGT 150M-300M	A2165002
	Tubing 3/8" x 1/4" Black Poly (MGT-120)	A2165007
10	Complete Brine Tank Assembly for MGT 120M (10" Shelf Height)	B1295015
	Complete Brine Tank Assembly for MGT 150M (13" Shelf Height)	B1295016
	Complete Brine Tank Assembly for MGT 180M (15" Shelf Height)	B1295017
	Complete Brine Tank Assembly for MGT 210M (18" Shelf Height)	B1295018
	Complete Brine Tank Assembly for MGT 240M (20" Shelf Height)	B1295019
	Complete Brine Tank Assembly for MGT 270M (23" Shelf Height)	B1295020
	Complete Brine Tank Assembly for MGT 300M (26" Shelf Height)	B1295021

# MGT 2" 60M-600M NXT2 TWIN ALTERNATING MAINTENANCE

## BRINE SYSTEM - 450M

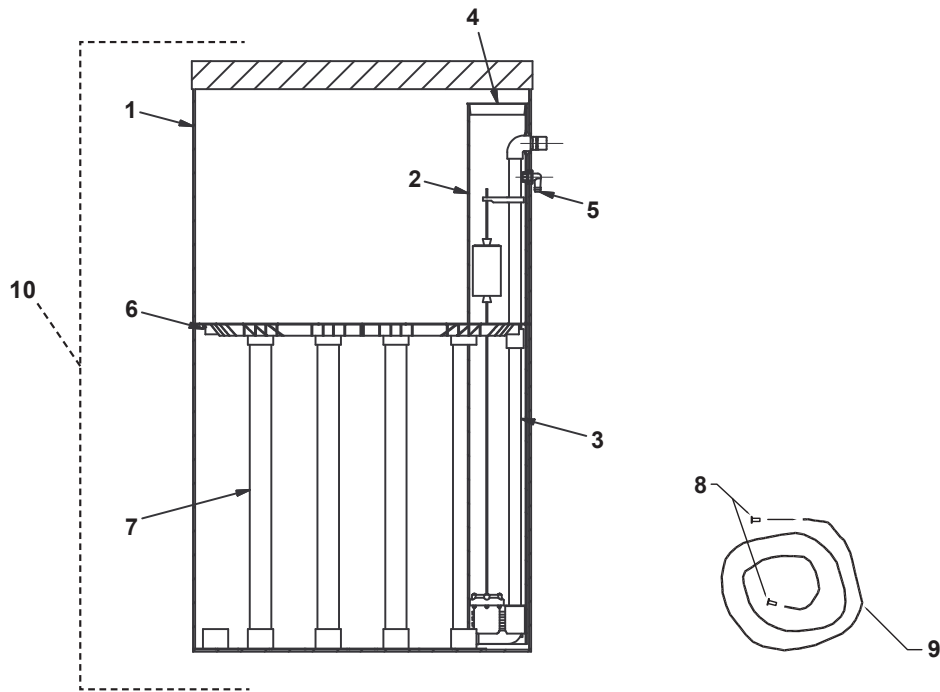

Item Number	Description	Part Number
1	Brine Tank 30" x 50" w/ Holes - MGT 450M	B1002041
2	5" x 48" Drilled Brine Well	B1015005
3	Brine Valve Assembly 16-1/4" x 24"	B1042007
4	5" Red Cap plug	A2072001
5	1/2" Overflow Elbow w/ Nut	A2250003
6	30" Plastic Top/Bottom Grid Plate	A2284010
7	1-1/2" SDR or SCH40 DWV Pipe	A2275007
8	1/2" Poly Insert	A2476001
9	1/2" x 3/8" Black Poly Tubing	A2165002
10	Complete Brine Tank Assembly for MGT 450M	B1141009

# MGT 2" 60M-600M NXT2 TWIN ALTERNATING MAINTENANCE

## BRINE SYSTEM - MGT 600M

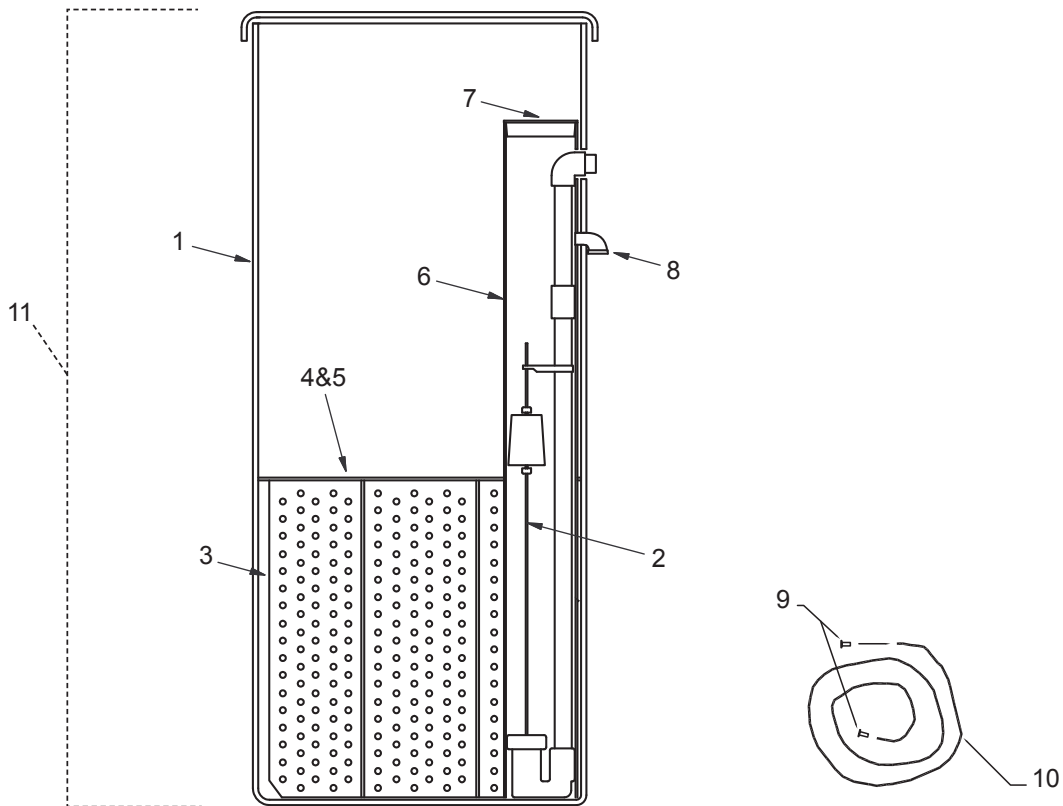

Item Number	Description	Part Number
1	Tank Brine 39 X 60 Black Mld Cvr	B1002010
2	Brine Valve Assy 10-1/4 X 30	B1042006
3	Grid Support Set 39 Dia 22"	B1043009
4	Salt Shelf 38-1/8 Dia.	B1041003
5	Salt Screen 39 Dia.	B1040003
6	Brine Well 5 X 48 Slotted	B1015005
7	Cap Brine Well Red 5 Inch	A2072001
8	Brine Tank Overflow Assembly	B1233003
9	Insert 1/2 Poly (P8TS6)	A2476001
10	Tubing 1/2x3/8 Black Poly (H1041)	A2165002
11	Mgt 600m Brine Tank Assembly	B1141005

# MGT 2" 60M-600M NXT2 TWIN ALTERNATING MAINTENANCE

---

## **SERVICE ASSEMBLIES**

### **AUXILIARY MICRO SWITCH**

- A2154001 Valve/RO Lockout (10218)
- A2154003 Homing Switch (10896)

### **BRINE VALVES**

- B1042012 Model 16006 Brine Valve Assy. - 1GGPM (60029&60020-100)
- A2254002 Model 1600 Brine Valve Assy. - 2 GPM (60034-20)
- A2254003 Model 1600 Brine Valve Assy. - 5 GPM (60034-50)

### **COVERS**

- A2103095 Environmental - Upper Cover (60219-02)
- A2103096 Environmental - Lower Cover (60217-02)

### **DRAIN LINE FLOW CONTROLS**

- A2253009 DLFC 1" FNPT x 3/4" FNPT 3.5 GPM (60) (60366-35)
- A2253010 DLFC 1" FNPT x 3/4" FNPT 5.0 GPM (90) (60366-50)
- A2253011 DLFC 1" FNPT x 3/4" FNPT 6.0 GPM (120) (60366-60)
- A2138011 DLFC 1" MNPT 8.0 GPM (150)
- A2138013 DLFC 1" MNPT 12.0 GPM (180&210)
- A2138014 DLFC 1" MNPT 15.0 GPM (240&300)
- A2138023 DLFC 1" MNPT 25.0 GPM (450)
- A2138024 DLFC 1" MNPT 30.0 GPM (600)

### **CAM ASSEMBLY**

- A2300014 Drive Cam STF Blue (60160-15)
- A2300005 Lower Drive Cam (14775)
- A2490014 Shutoff Cam (12777)

### **O-RINGS**

- A2077115 Valve Base O-Ring (13575)
- A2077117 Distributor O-Ring (13577)

### **PISTON ASSEMBLIES**

- A2309054 Upper Piston (61540)
- A2309056 Lower Piston Hard Water By-Pass (61550)
- A2309055 Lower Piston No Hard Water By-Pass (61555)

### **SEAL & SPACER KITS**

- A2435011 Upper Kit (61530)
- A2435026 Lower Kit (60128)

### **SERVICE EQUIPMENT**

- A2475001 Seal & Spacer Stuffer Tool - Upper (11098)
- A2475003 Seal & Spacer Stuffer Tool --Lower (12683)
- A2474001 Spacer Puller Tool - Upper (13061)
- A2474003 Spacer Puller Tool --Lower (12682)
- A2423002 Silicone, 24oz. Tube (16174)

### **METER ASSEMBLIES**

- A2360057 Fleck 2" Plastic Meter Assy (60625)
- A2360083 Fleck 2" Stainless Steel Meter Assy (61934-10)
- A2426203 Clack 2" Stainless Steel Meter w/15' Cable
- A2296001 Signet Paddlewheel Flow Sensor w/Cable

### **METER CABLES (FOR FLECK VALVES)**

- A2352067 Cable 35 inches (for 2" Plastic Mtr)
- A2352062 Cable 99.5 inches (for 2" Plastic Mtr)
- A2315021 Cable 25 foot (for 2" Plastic Mtr)
- A2352092 Cable 30 inches (for 2" SS Mtr)
- A2352154 Cable 100 inches (for 2" SS Mtr)
- A2352093 Cable 25 foot (for 2" SS Mtr)

### **TRANSFORMERS**

- A2242160 Power Supply US 120V, 24VDC
- A2242161 Power Supply EU 220V, 24VDC

### **NXT2 TIMER ASSEMBLY**

- A2084089 NXT2 Timer & Bracket Assy
- A2084088 NXT to NXT2 Conversion Kit

# MGT 2” 60M–600M NXT2 TWIN ALTERNATING MAINTENANCE

## TROUBLESHOOTING

### DETECTED ERRORS

**NOTE: It can take up to 30 seconds for an error to be detected and displayed. All errors on each timer in the system must be displayed before the errors can be corrected.**

If a communication error is detected, an Error Screen will appear.

- All units In Service remain in the In Service position.
- All units in Standby go to In Service.
- Any unit in Regeneration when the error occurs completes Regeneration and goes to In Service.
- No units are allowed to start a Regeneration Cycle while the error condition exists, unless they are manually forced into Regeneration.
- When an error is corrected and the error no longer displays (it may take several seconds for all of the units in a system to stop displaying the error message), the system returns to normal operation.

**NOTE: During the error condition the control continues to monitor the flow meter and update the volume remaining. Once the error condition is corrected all units return to the operating status they were in prior to the error. Regeneration queue is rebuilt according to the normal system operation. Or, if more than one unit has been queued for regeneration, then the queue is rebuilt according to which one communicates first.**

Message Displayed	Cause For Error	Correction
"Error Valve Count Mismatch"	Number of NXT2 detected does not match selected system type in Master Programming	"Push correct valve settings in Master Settings"
"Motor Stall No Changes Detected in the Optical Sensor for 6 Seconds"	The motor is on but no encoder pulses are detected within a given duration while homing.	Check the P11 connection and trigger a manual regeneration.
"Motor Run-On No CAM Switch Change Detected"	The motor is on but no encoder pulses are detected or CAM Switches change state within a given duration.	Verify correct valve type is chosen. Trigger a manual regeneration.
Optical Sensor Undesired change detected by the Optical Sensor	The motor is off but additional encoder pulses are detected.	Trigger a manual regeneration.
"Over-Current Motor Over-Current is Detected"	Motor current exceeds thresholds.	Trigger a manual regeneration.
"Flow Meter Error Continuous Flow Detected"	Flow exceeded specified threshold for a specific duration.	Trigger a manual regeneration.
"Error Send/Receive Failure"	During a setting push, a packet was missing.	Reconnect communication cables and push setting in Master Settings.
"Error System Type Mismatch on Network"	The system type among connected units does not match.	"Push correct system settings in Master Settings."
Microcontroller Error	Calibration or manufacturing test was not performed	Contact your Pentair representative.
100 Days Without Regen	100 Days have expired without a regeneration	Trigger a manual regeneration

# MGT 2" 60M-600M NXT2 TWIN ALTERNATING MAINTENANCE

## TROUBLESHOOTING 2900 VALVE

PROBLEM	CAUSE	CORRECTION
Softener Fails To Regenerate.	<ul style="list-style-type: none"> <li>A. Electrical Service To Unit Has Been Interrupted.</li> <li>B. Timer Is Defective.</li> <li>C. Power Failure.</li> </ul>	<ul style="list-style-type: none"> <li>A. Assure Permanent Electrical Service (Check Fuse, Plug, Pull Chain or Switch).</li> <li>B. Replace Timer.</li> <li>C. Reset Time of Day.</li> </ul>
Hard Water.	<ul style="list-style-type: none"> <li>A. By-Pass Valve is Open.</li> <li>B. No Salt in Brine Tank</li> <li>C. Injector Screen Plugged.</li> <li>D. Insufficient Water Flowing Into Brine Tank</li> <li>E. Hot Water Tank Hardness.</li> <li>F. Leak At Distributor Tube.</li> <li>G. Internal Valve Leak</li> <li>H. Service Adapter Did Not Return To Service.</li> </ul>	<ul style="list-style-type: none"> <li>A. Close By-Pass Valve.</li> <li>B. Add Salt To Brine Tank and Maintain Salt Level Above Water Level.</li> <li>C. Clean Injector Screen.</li> <li>D. Check Brine Tank Fill Time And Clean Brine Line Flow Control If Plugged.</li> <li>E. Repeated Flushings Of The Hot Water Tank is Required.</li> <li>F. Make Sure Distributor Tube Is Not Cracked. Check O-Ring And Tube Pilot.</li> <li>G. Replace Seals and Spacers And/ Or Piston.</li> <li>H. Check Drive Motor And Switch.</li> </ul>
Unit Used Too Much Salt	<ul style="list-style-type: none"> <li>A. Improper Salt Setting.</li> <li>B. Excessive Water in Brine Tank</li> </ul>	<ul style="list-style-type: none"> <li>A. Check Salt Usage and Salt Setting.</li> <li>B. See Problem No. 7.</li> </ul>
Loss Of Water Pressure.	<ul style="list-style-type: none"> <li>A. Iron Buildup In Line To Water Conditioner.</li> <li>B. Iron Buildup in Water Conditioner.</li> <li>C. Inlet of Control Plugged Due to Foreign Material Broken Loose From Pipes By Recent Work Done On Plumbing System.</li> </ul>	<ul style="list-style-type: none"> <li>A. Clean Line To Water Conditioner.</li> <li>B. Clean Control and Add Mineral Cleaner to Mineral Bed. Increased Frequency of Regeneration.</li> <li>C. Remove Piston and Clean Control.</li> </ul>
Loss of Mineral Through Drain Line.	<ul style="list-style-type: none"> <li>A. Air In Water System.</li> <li>B. Improperly Sized Drain Line Flow Control.</li> </ul>	<ul style="list-style-type: none"> <li>A. Assure That Well System Has Proper Air Eliminator Control. Check For Dry Well Condition.</li> <li>B. Check For Proper Drain Rate.</li> </ul>
Iron In Conditioned Water.	<ul style="list-style-type: none"> <li>A. Fouled Mineral Bed.</li> </ul>	<ul style="list-style-type: none"> <li>A. Check Backwash, Brine Draw And Brine Tank Fill. Increase Frequency of Regeneration. Increase Backwash Time.</li> </ul>

# MGT 2" 60M-600M NXT2 TWIN ALTERNATING MAINTENANCE

## TROUBLESHOOTING 2900 VALVE (CONTINUED)

PROBLEM	CAUSE	CORRECTION
7. Excessive Water In Brine Tank.	<ul style="list-style-type: none"> <li>A. Plugged Drain Line Flow Control.</li> <li>B. Plugged Injector System.</li> <li>C. Timer Not Cycling.</li> <li>D. Foreign Material In Brine Valve.</li> <li>E. Foreign Material In Brine Line Flow Control.</li> </ul>	<ul style="list-style-type: none"> <li>A. Clean Flow Control.</li> <li>B. Clean Injector and Screen.</li> <li>C. Replace Timer.</li> <li>D. Replace Brine Valve Seat And Clean Valve.</li> <li>E. Clean Brine Line Flow Control.</li> </ul>
8. Softener Fails To Draw Brine.	<ul style="list-style-type: none"> <li>A. Drain Line Flow Control Is Plugged.</li> <li>B. Injector Is Plugged.</li> <li>C. Injector Screen Plugged.</li> <li>D. Line Pressure Is Too Low.</li> <li>E. Internal Control Leak</li> <li>F. Service Adapter Did Not Cycle.</li> </ul>	<ul style="list-style-type: none"> <li>A. Clean Drain Line Flow Control.</li> <li>B. Clean Injector.</li> <li>C. Clean Screen.</li> <li>D. Increase Line Pressure To 20 P.S.I.</li> <li>E. Change Seals, Spacers and Piston Assembly.</li> <li>F. Check Drive Motor And Switches.</li> </ul>
9. Control Cycles Continuously.	<ul style="list-style-type: none"> <li>A. Misadjusted, Broken or Shorted Switch.</li> </ul>	<ul style="list-style-type: none"> <li>A. Determine If Switch or Timer Is Faulty and Replace It or Replace Complete Power Head.</li> </ul>
10. Drain Flows Continuously.	<ul style="list-style-type: none"> <li>A. Valve Is Not Programming Correctly.</li> <li>B. Foreign Material In Control.</li> <li>C. Internal Control Leak</li> </ul>	<ul style="list-style-type: none"> <li>A. Check Timer Program and Positioning of Control. Replace Power Head Assembly If Not Positioning Properly.</li> <li>B. Remove Power Head Assembly And Inspect Bore. Remove Foreign Material and Check Control In Various Regeneration Positions.</li> <li>C. Replace Seals and Piston Assembly.</li> </ul>

### General Service Hints For Meter Control

Problem: Softener Delivers Hard Water.

Cause could be that . . . Reserve Capacity Has Been Exceeded.

Correction: Check salt dosage requirements and reset program wheel to provide additional reserve.

Cause could be that . . . Meter Is Not Measuring Flow.

Correction: Check meter with meter checker.

