



REVERSE OSMOSIS

MODELS

MRO-2.5 500 GPD

(For models manufactured November 2012 and beyond.)

INSTALLATION, OPERATION, AND MAINTENANCE MANUAL

COMPLETE FOR FUTURE REFERENCE:

MODEL NO:

SERIAL NO:

DATE INSTALLED:

DEALER:

Marlo Incorporated
2227 South Street
P.O. Box 044170
Racine, WI 53404-7003
www.Marlo-Inc.com

TABLE OF CONTENTS**SYSTEM INFORMATION**

Warranty Information	3
Introduction	4
System Specifications	5
Feedwater & Operation Specifications	6

INSTALLATION

Plumbing.....	7
Electrical	7
Pre-Filtration	7
Pump	7
Mounting	7
Membrane Elements	8
Start-Up	8

OPERATION & MAINTENANCE

Inlet Valve Override	10
Components	10
Membrane Removal & Replacements.....	11
Flushing The System.....	12
Draining The System	12
Daily Log.....	13
Temperature Correction Factors.....	14
Conversion Table.....	15
General Arrangement Drawings	16
Wiring Diagram.....	17
Storage Tank Options	18
Tubing Diagram	23
Parts List & Breakout Diagram	24
Troubleshooting.....	26
Terms & Definitions.....	29
Vendor Component Documentation	33

COMMERCIAL & INDUSTRIAL PRODUCT WARRANTY

Marlo, Inc. warrants all commercial and industrial water treatment products manufactured and/or distributed by it to be free from defects in materials and workmanship for a period of one (1) year from the date of shipment. If within that period any products shall be proven to Marlo, Inc.'s satisfaction to be defective, those products will be replaced or the price refunded at Marlo Inc.'s option.

Marlo Inc.'s obligations or nonperformance, defective, or any damage caused by its products or their use, and buyer's exclusive remedy therefore, shall be limited to product replacement or refund and shall be conditioned upon Marlo Inc.'s receiving written notice together with a demand for such replacement or refund:

The foregoing warranty is exclusive and in lieu of all other expressed implied warranty (except of title) including but not limited to implied warranty of merchantability and fitness for particular purpose.

Marlo Inc. will not be subject to and disclaims the following:

1. Any other obligations or liabilities arising out of breach of contract or out of warranty.
2. Any obligations whatsoever arising from tort claims (including negligence and strict liability or arising under other theories of law with respect to products sold or services rendered by Marlo Inc. or any undertakings, acts, or omissions relating thereto.
3. All consequential, incidental, and contingent damages.

Labor charges, charge backs or handling charges are excluded from Marlo Inc.'s warranty provisions.

INTRODUCTION

Your MRO commercial reverse osmosis system is a durable piece of equipment which, with proper care, will last for many years. This User's Manual outlines installation, operating, maintenance, and troubleshooting details vital to the sustained performance of your system.

The test results which are included with this User's Manual indicate your system's permeate (product) and rejection test results. Your system is designed to operate at a pressure of 150 psi, unless otherwise stated. The recovery set for your system is between 33%-50%.

If your system is altered at the site of operation or if the feed water conditions change, please contact your local dealer or distributor to determine the proper recovery for your application. **NOTE:** In order to maintain warranty, an operating log must be maintained. Copies must be sent to your local dealer or distributor for review.

NOTE: Prior to operating or servicing the MRO commercial reverse osmosis system, this User's Manual must be read and fully understood. Keep it and other associated information for future reference and for new operators or qualified personnel near the system.

SAFETY

The Safety section of this User's Manual outlines the various safety headings used throughout this manual's text and are enhanced and defined below:

NOTE: Indicates statements that provide further information and clarification.

CAUTION: Indicates statements that are used to identify conditions or practices that could result in equipment or other property damage.

WARNING: Indicates statements that are used to identify conditions or practices that could result in injury or loss of life. **FAILURE TO FOLLOW WARNINGS COULD RESULT IN SERIOUS INJURY OR EVEN DEATH.**

LABELING

Do not under any circumstance, remove any Caution, Warning, or other descriptive label from the system.

SYSTEM SPECIFICATIONS

Model	MRO-500
Design	Vertical
Gallons Per Day	500 @ 77°F
Dimensions (approx.)	22" X 22" X 45"
Weight (approx)	65 lbs.
Element Size (In.)	2.5" x 21"
Elements (qty.)	2
Motor HP	1/3
Voltage	110
Hertz	60
Feed Connection	1" NPT
Product Connection	1/2" Tube
Waste Connection	3/8" Tube

WITH WATER SOFTENER	
RO Flowrates at 77°F @ 33% Recovery	MRO-500
Feed Water (less than 10 gpg)	0.6 GPM
Permeate	0.3 GPM
Concentrate / Reject	0.3 GPM
Recycle	0.5 GPM

NOTE: Flowrate specifications @ 33% recovery (use these values to maximize membrane lifespan).

WITHOUT WATER SOFTENER	
RO Flowrates at 77°F @ 50% Recovery	MRO-500
Feed Water (Maximum 1 gpg)	1.0 GPM
Permeate	0.3 GPM
Concentrate / Reject	0.7 GPM
Recycle	0.5 GPM

NOTE: Flowrate specifications @ 50% recovery (use these values to minimize waste water usage).

GPM = GPD/1440

WARNING: Never exceed 150 PSI membrane feed pressure.

NOTE: The MRO 500 reverse osmosis systems are equipped with a concentrate control valve. This valve is used to adjust the system to the desired recovery. Feed water enters the system through an automatic shut-off valve. Ensure that the valve opens when the system turns on, allowing water to flow through the system, and close when the system turns off, stopping the water from flowing through the system. This will save water and prevent premature fouling of the reverse osmosis membrane.

MRO-500 CONTROL PANEL

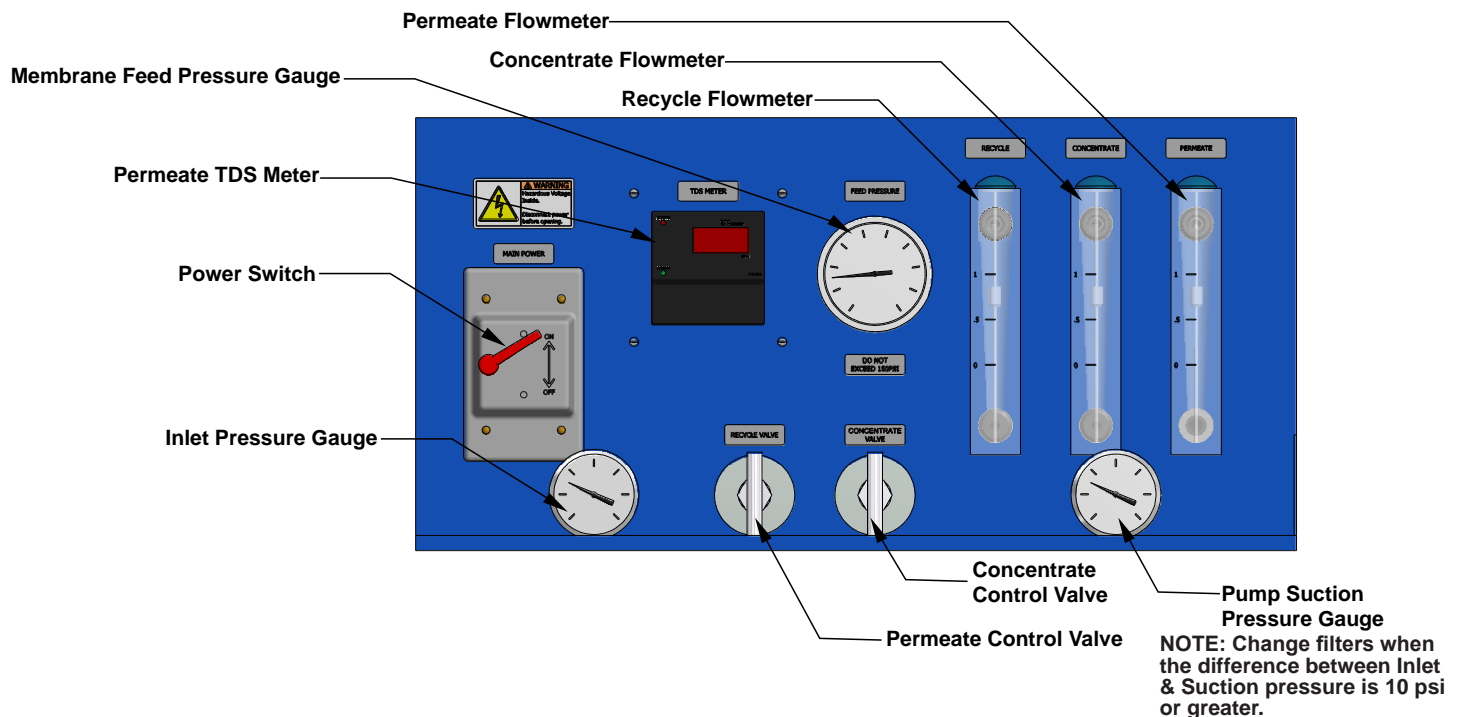

FEED WATER & OPERATION SPECIFICATION

Nothing has a greater effect on a reverse osmosis system than the feed water quality. For lasting performance it is important to supply the system with the feed water quality shown below. It is also important to feed the system the required amount of feed water. **NOTE:** It is very important to meet the feed water requirements. Failure to do so will cause the membranes to foul and void the warranty.

FEED WATER SPECIFICATIONS

Hardness	<1 grain	Hydrogen Sulfide	0 ppm
Free Chlorine	0 ppm	Manganese	<0.05 ppm
Total Dissolved Solids	<2000 ppm	Organics	<1 ppm
Turbidity (SDI)	<5	Temperature	40°F–80°F

The manufacturer has provided you with operation specifications. These specifications should be met in order to have the reverse osmosis system perform optimally. All operation specifications are based on the test conditions listed below.

OPERATION SPECIFICATIONS

Min. Feed Pressure	35 psi	Max. Pressure	150 psi
Min. NaCl % Rejection	96%	Max. NaCl % Rejection	98%
Min. Feed (GPM)	1.5	Max. Feed (GPM)	3
Max. Hardness	15 Grains / Gallon	pH Range	3 – 11
Max. TDS	2000 ppm	Max. Temperature	105°F
Test Conditions: Permeate flow and salt rejection based on 2000 ppm NaCl, 150 psi, 77°F (25°C), pH 7, and recovery as indicated. NOTE: Higher TDS and/or lower temperatures will reduce the system's production.			

REJECTION, RECOVERY, & FLOW RATES

MRO reverse osmosis systems are designed to produce purified water at the capacities indicated by the suffix in the system's name under the conditions listed above. For example, the MRO 500 produces 500 gallons per day of purified water with an inlet water temperature of 77°F.

The amount of total dissolved solids (TDS) rejected by the membrane is expressed as a percentage. For example, a 99% rejection rate means that 99% of total dissolved solids do not pass through the membrane. To calculate the % rejection, use the following formula:

$$\% \text{ Rejection} = (\text{Feed TDS} - \text{Product TDS} / \text{Feed TDS}) \times 100$$

NOTE: All TDS figures must be expressed in the same units, usually parts per million (ppm) or milligrams per liter (mg/l).

MRO commercial reverse osmosis systems are designed to reject up to 98% NaCl, unless computer projections have been run and provide a different rejection percentage. The amount of purified water recovered for use is expressed as a percentage recovery. To calculate % recovery, use the following formula:

$$\% \text{ Recovery} = (\text{Product Water Flow Rate} / \text{Feed Water Flow Rate}) \times 100$$

NOTE: All Flow Rates must be expressed in the same units, usually gallons per minute (gpm). MRO commercial reverse osmosis systems are designed to have a recovery of 33% - 50%, unless computer projections have been run and provide a different recovery percentage.

SYSTEM REQUIREMENTS & OPERATION GUIDELINES

PLUMBING

The membranes and high pressure pumps used on MRO systems require a continuous and non-turbulent flow of water to the system with a minimum feed pressure of 35 psi, which does not exceed a temperature of 105°F.

The tubing or piping used for the inlet of the concentrate is 1" NPT. The tubing or piping used for the discharge of the concentrate is 3/4" O.D. tube and should be run to an open drain in a free and unrestricted manner.

The tubing or piping used for the permeate is 3/8" O.D. tube and can be transported to the holding tank or directly to the point-of-use through a high quality nylon, tubing or PVC pipe, or other FDA accepted materials.

Material must not precipitate in the system. Be certain that all of the components of the feed water are soluble at the concentrations attained in the system. A system operating at 33% recovery, concentrates nearly all impurities 1.5 times. A system operating at a 50% recovery concentrates nearly all impurities 2 times. If the feed water contains a slightly soluble material such as calcium sulfate, silica, or colloidal clay, an anti-scalant should be used.

CAUTION: Any restrictions or blockage in the drain can cause backpressure, which will increase the system's operating pressure. This can result in damage to the system's components.

ELECTRICAL

The motors used on the MRO 500 systems are carbonator motors. They are available in 120V/60Hz/1Ph.

Please ensure that the electrical circuit supplying the system is compatible with the requirements of the specific MRO model.

NOTE: We recommend that a licensed electrician install your system in accordance with local and national electrical codes.

WARNING: To reduce the risk of electrical shock, the incoming power supply must include a protective earth ground.

Each MRO system is equipped with an 6 foot electrical cord. All 110 volt system's are provided with a 3 prong plug for use in a standard North American household outlet receptacle.

PRE-FILTRATION

MRO systems are supplied with a polypropylene pre-filter that filters out most particles over 5 microns, and a carbon block that removes chlorine; before the water is pumped through the reverse osmosis membrane. Change the cartridges at least every month or whenever there is a pressure difference of 10 psi or greater between the pressure readings before and after the filter.

NOTE: The system must be operated on filtered water only. Do not attempt to clean used filter cartridges.

CAUTION: If the pre-filter becomes clogged and the water flow to the pump is reduced or interrupted, cavitation will occur. This will damage the pump.

PUMP

The pumps used on the MRO 500 systems are stainless steel rotary vane pumps. Follow these guidelines to ensure proper operation of the pump:

- The pump must NEVER be run dry. Operating the pump without sufficient feed water will damage the pump.
- ALWAYS feed the pump with filtered water. The pump is susceptible to damage from sediment and debris.

MOUNTING

The free standing system should be bolted down in compliance to local regulation standards. It has a lightweight and portable design for a variety of applications.

MEMBRANE ELEMENTS

MRO reverse osmosis systems come preloaded with Thin Film Composite High Flow membranes. General membrane element performance characteristics are listed below:

MEMBRANE ELEMENT CHARACTERISTICS

Min. Working Pressure	100 psi	Max. Pressure	400 psi
Min. NaCl % Rejection	96%	Max. NaCl % Rejection	98%
Min. Feed (GPM)	1.5	Max. Feed (GPM)	3
3Max. Hardness	15 Grains / Gallon	pH Range	3 – 11
Max. TDS	2000 ppm	Max. Temperature	105°F
Thin Film Composite (TFC) Membranes			
Test Conditions: Permeate flow and salt rejection based on 2000 ppm NaCl, 150 psi, 77°F (25°C), pH 7, and recovery as indicated. NOTE: Higher TDS and/or lower temperatures will reduce the system's production.			

NOTE: Unless otherwise indicated, these instructions cover the MRO 500 reverse osmosis systems. Please refer to the flow diagrams and exploded view diagrams found in this User's Manual for additional information.

INSTALLATION

The MRO reverse osmosis systems are free standing and require no special installation; however, if placed on an uneven floor, the system may vibrate. If this occurs, place the system on a rubber mat to reduce the vibrations.

Carefully inspect your system before start-up. Check all plumbing and electrical connections. Connections may have come loose during shipment.

START-UP

1. Locate the feed water inlet on the pre-filter housing.
2. Attach the inlet tubing to the feed water source, or permanently plumb the feed water piping or tubing to the inlet. Always maintain a smooth and sufficient flow of feed water during operation.
3. Locate the permeate tubing.
4. Attach the permeate tubing to the permeate outlet. Make sure that the permeate water can flow freely and that there is no backpressure. Backpressure can cause damage to the membrane.

CAUTION: The plumbing in the permeate line can contaminate the high quality water produced by the system; ensure that the components are compatible with the application. The pH of the reverse osmosis permeate will normally be 1-2 points lower than the feed water pH. A pH of 6.5 or lower can be very aggressive to some plumbing materials, such as copper piping.

5. Locate the concentrate (waste) tubing. Locate the concentrate outlet on the drain side of the concentrate control valve.
6. Attach, the drain line to the concentrate tubing.
7. Run the concentrate line to the drain. Water must be allowed to run freely, without any restrictions or blockage in the drain line. Make sure that no backpressure exists on the concentrate line.
8. Ensure that the electrical power requirements of the MRO system match your electrical power supply.
9. MRO systems are typically controlled with a liquid level switch in a storage tank. The liquid level switch turns the system on when the water level in the tank drops, and off when the tank is full. Liquid level switches can be obtained by your local dealer or distributor. If a liquid level switch is to be used, install it at this time and turn the power to the MRO system on. Otherwise, turn the system on by plugging in the power cord. Allow the system to run for about three to five minutes with the concentrate control valve fully open to purge air from the system.

10. The MRO system's permeate or product water should be discarded for the first hour of operation. This will flush out any impurities which are in the system. Turn the concentrate control valve until the concentrate pressure gauge indicates a pressure of 50 psi. Flush the system at 50 psi for 1 hour to remove the impurities from the system. Check for leaks. All MRO reverse osmosis systems are fully tested prior to shipment, but leaks may occur due to shipping.
11. Connect the permeate line to the storage tank or point-of-use application. Make sure that no backpressure exists on the permeate line.
12. Locate the concentrate control valve and the concentrate pressure gauge.
13. Turn the concentrate control valve until the designated permeate flow is acquired. For example a MRO 500 should be adjusted until it produces about 500 GPD or 0.3 GPM of permeate or product water. The concentrate pressure will increase as the concentrate control valve is closed. The exact operating pressure may vary depending on the temperature and TDS of your feed water. It may be necessary to re-adjust the system if there is a major change in feed water temperature and/or TDS. Set the permeate, concentrate and recycle flowrates to the values shown below by adjusting the pump bypass valve, concentrate valve, and recycle valve.

OPERATION & MAINTENANCE

The reverse osmosis process causes the concentration of impurities in the concentrate stream to increase. The impurities may precipitate (come out of the solution) when their concentration reaches saturation levels.

NOTE: Precipitation can scale or foul membranes and must be prevented.

Check your feed water chemistry. Pre-treat the water and/or reduce the system recovery as required. If necessary, consult with your local dealer or distributor.

INLET VALVE MANUAL OVERRIDE

The automatic inlet valve has a manual override function to enable the operator to flush out the preservative solution before starting up the unit.

See diagrams below for position of the white manual override lever.

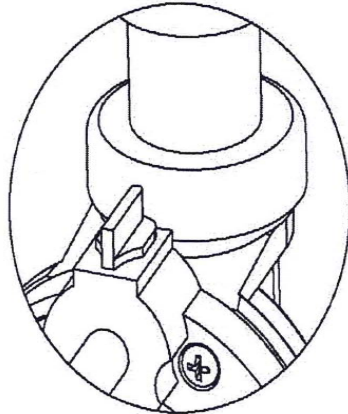

MANUAL OVERRIDE
LEVER SHOWN IN
SERVICE (AUTOMATIC)
POSITION

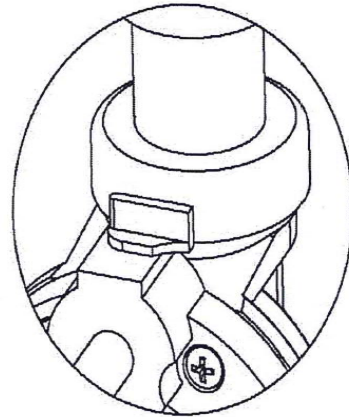

MANUAL OVERRIDE
LEVER SHOWN IN
OVERRIDE (MANUAL)
POSITION

PRE-FILTER PRESSURE GAUGES

These gauges measure the feed water pressure when it enters and exits the pre-filter housing.

PRODUCT (PERMEATE) FLOW METER & WASTE (CONCENTRATE) FLOW METER

These flow meters indicate the flow rates of permeate and concentrate water. The measurements, when added together, also indicate the feed water flow rate.

WASTE RECYCLE VALVE

This valve allows you to recycle some of the concentrate water back to the feed of the pump. This will increase the recovery of the MRO system. The amount of waste water recycled is limited by the TDS of the feed water. The drawback of using concentrate recirculate is an increase of total dissolved solids in the permeate water.

CAUTION: Excessive recycling may cause premature fouling or scaling of the membrane elements.

LOW PRESSURE SWITCH

The low pressure switch shuts off the system when the feed water pressure drops too low for the system to function properly. This prevents damage to the pump. The system restarts automatically when the pressure is restored. If you notice the pressure fluctuating, and the system cycling off and on repeatedly, turn the system off and ensure that proper feed flow and pressure are available to the system.

PUMP BYPASS VALVE

This valve is installed as a standard feature on the MRO 500 reverse osmosis systems. It provides an adjustment for pump pressure, which will vary as the required system pressure changes.

INCREASE PRESSURE

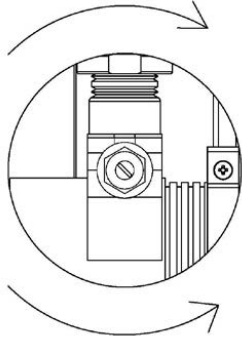

DECREASE PRESSURE

ADJUSTING THE BYPASS VALVE

Use a fat screw driver to increase or decrease the pressure to the bypass valve. To increase the pressure turn the screw clockwise. To decrease the pressure and turn the screw counter clockwise. (See figure to the left)

EXAMPLE:

As the feed water temperature decreases, and/or the feed water TDS increases, the system will require a higher operating pressure to produce the specified permeate flow. A MRO system installed in Florida may provide the specified permeate flow of 1.74 gpm at 100 psi; however the same system installed in Maine – much colder feed water – may require 140 psi to produce the same amount of permeate. The system in Florida would have a higher concentrate flow to the drain because of the lower operating pressure, which would result in poor system recovery.

$$\% \text{ Rejection} = (\text{Feed TDS} - \text{Product TDS}) / (\text{Feed TDS}) \times 100$$

MEMBRANE REMOVAL & REPLACEMENT

Changing membranes in pressure vessels is an easy process if you have the proper information and tools at hand. Please refer to the following instructions when removing and replacing membrane elements:

1. Remove the end caps from the top of the membrane housings.
2. Remove the membrane bag containing the membrane element from the shipping box.
3. Cut the bag open as close as possible to the seal at the end of the bag, so the bag may be re-used if necessary.
4. Remove the membrane element from the bag and remove the black core tube protectors from each end of the membrane.
5. Remove parts from the parts container (if included) and inspect. Make sure that all parts are clean and free from dirt. Examine the brine seal, and permeate tube for nicks or cuts. Replace the O-rings or brine seal if damaged.
6. Flow directions should be observed for installation of each element in each housing.

As time progresses, the efficiency of the membrane will be reduced. In general, the salt rejection does not change significantly until two or three years after installation when operated on properly pretreated feed water. The permeate flow rate will begin to decline slightly after one year of operation, but can be extended with diligent flushing and cleaning of the system. A high pH and/or precipitation of hardness can cause premature loss in rejection of membrane elements in the system.

To replace the membrane elements:

1. Remove all of the membrane element(s) from the membrane element housings from the top of the housing. Heavy-duty pliers and channel lock pliers may be necessary to pull the old membrane element out of the membrane element housing.
2. Install the brine seal side of the membrane elements first. When the housings have a direction of flow from bottom to top, the brine seal should be located on the end of the membrane element at the bottom of the housing.

3. Lubricate the brine seal with a food grade lubricant.
4. At a slight angle insert membrane while slightly rotating element being careful not to tear or flip the brine seal. Re-lube the brine seal if necessary.
5. With a smooth and constant motion, push the membrane element into the housing so that the brine seal enters the housing without coming out of the brine seal groove. A slow twisting motion should be used to insert the membrane element, to ensure that the brine seal stays in place.
6. Re-install the end caps by gently twisting the end cap while pushing it onto the housing. Ensure that you do not pinch or fatigue any O-rings while pushing the end plug on. Push the end plug on until the outer diameter of the plug is flush with the outer diameter of the membrane housing.
7. Re-attach the end cap retaining clips.
8. Reconnect any fittings that may have been disconnected when the membrane element housings were disassembled.
9. To Start-Up the system, refer to Start-Up

CAUTION: New or factory cleaned membranes are shipped in a preservative solution. New or cleaned membranes must be flushed for at least 1 hour to remove the preservative from the membrane. Discard all of the permeate and concentrate, which is produced during the flush.

FLUSHING THE SYSTEM

The system should be flushed weekly to remove sediment from the surface of the membranes. To manually flush the system following the preceding steps:

1. The system must be running during the flushing procedure.
2. Open the concentrate valve until the pressure gauge reads approximately 50 psi (3.5 bar). NOTE: If pressure will not drop to approximately 50 psi (3.5 bar) pressure during flushing, the concentrate valve must be cleaned.
3. Allow the system to run for 10 to 20 minutes.
4. After 10 to 20 minutes, close the concentrate valve to its previous position, raising the operating pressure to 150 psi. Ensure the proper concentrate flow rate is going to the drain.
5. The system is now ready to operate.

DRAINING THE SYSTEM FOR SHIPMENT

Prior to shipping or storing your system, the system should be cleaned with an appropriate cleaner, flushed with water, and protected from biological attack with an appropriate solution for membrane elements. The membrane housing(s) and plumbing lines of the system must be completely drained. Any water remaining in the plumbing of a system may freeze, causing serious damage. The party shipping or storing the system is responsible for any damage resulting from freezing. To drain the system:

1. Disconnect the inlet, concentrate, pre-filter, and permeate plumbing.
2. Drain all water from the pre-filter cartridge housings by unscrewing the housings, removing the pre-filter cartridges, and drain the water from the housings.
3. Disconnect the tubing from the connector on the permeate and concentrate inlets and outlets.
4. Fully open the concentrate valve.
5. Drain the flow meters by disconnecting the tubing from the bottom fitting of each meter.
6. Allow the system to drain for a minimum of eight hours or until the opened ports quit dripping.
7. After draining is complete, reconnect all of the plumbing.



RO Daily Log

Marlo Job number: _____ Projected Permeate Flow Rate * _____

Model Number: _____ Projected Concentrate Flow Rate * _____

	UOM						
INLET WATER							
Date / Time							
Feed Water Hardness	GPG /PPM						
Feed Water Chlorine	PPM						
Feed Water Conductivity - (CF)	µS / PPM						
Feed Water pH	pH						
Feed Water Temperature	C or F						
Feed Water Inlet Pressure (pp) Δ	PSI						
Pump Suction Pressure- (sp) Δ	PSI						
Membrane Feed (**NOT TO EXCEED 150 PSI**)	PSI						
Permeate Conductivity (CP)	µS/ PPM						
Permeate Flow Rate - Qp	GPM						
Reject/Concentrate Flow Rate (GPM) Qr	GPM						
Recycle Flow Rate (if Applicable)	GPM						
Feed Flow Rate - Qf (Qr + Qp = Qf)	GPM						
Recovery Rate = (Qp/Qf) X 100	%						
Overall Rejection = (1-(CP/CF)) x 100 = %	%						
Filter Change	yes/ no						

* = Performance Data in Section 1 of manual

Notes: Δ When feed water inlet pressure and suction pressure differentials are greater than 20 psi = Change prefilter

Symbols : Q = Flow Rate, C = Conductivity, pp = prefilter pressure, sp = suction pressure, Qp = permeate flow, Qr = reject or concentrate flow, Qf = feed flow

TEMPERATURE CORRECTION FACTORS

35° F / 1.7° C = 0.53	77° F / 25.0° C = 1.00
40° F / 4.4° C = 0.56	80° F / 26.7° C = 1.04
45° F / 7.2° C = 0.62	85° F / 29.4° C = 1.10
50° F / 10.0° C = 0.68	90° F / 32.2° C = 1.17
55° F / 12.8° C = 0.73	95° F / 35.0° C = 1.23
60° F / 15.6° C = 0.78	100° F / 37.8° C = 1.30
65° F / 18.3° C = 0.85	105° F / 40.5° C = 1.39
70° F / 21.1° C = 0.90	110° F / 43.3° C = 1.45
75° F / 23.9° C = 0.97	115° F / 46.1° C = 1.51

CONVERSION TABLE

mg/L Sodium Chloride	Total Dissolved Solids as mg/L CaCO ₂	Specific Conductance (MicroSiemens/cm)	Specific Resistance Ohms/cm	Grains per Gallon Sodium Chloride
0.05	0.043	0.105	9,523.800	0.0029
0.1	0.085	0.212	4,716.980	0.0060
0.2	0.170	0.424	3,558.490	0.012
0.3	0.255	0.637	1,569.850	0.018
0.4	0.340	0.848	1,179.240	0.023
0.5	0.425	1.06	943.396	0.029
0.6	0.510	1.273	785.545	0.035
0.7	0.595	1.985	673.400	0.041
0.8	0.680	1.696	589.622	0.047
0.9	0.765	1.908	524.109	0.053
1	0.85	2.12	471.698	0.06
2	1.70	4.24	235.849	0.12
3	2.55	6.37	156.985	0.18
4	3.40	8.48	117.924	0.23
5	4.25	10.6	94.339	0.29
6	5.10	12.73	78.554	0.35
7	5.95	14.85	67.340	0.41
8	6.80	16.96	58.962	0.47
9	7.65	19.08	52.410	0.53
10	8.5	21.2	47.169	0.58
20	17.0	42.4	23.584	1.17
30	25.5	63.7	15.698	1.75
40	34.0	84.8	11.792	2.34
50	42.5	106.0	9.433	2.92
60	51.0	127.3	7.855	3.51
70	59.5	148.5	6.734	4.09
80	68.0	169.6	5.896	4.68
90	76.5	190.8	5.241	5.26
100	85	212	4.716	5.85
200	170	410	2.439	11.70
300	255	610	1.639	17.5
400	340	812	1.231	23.4
500	425	1,008	992	29.2
600	510	1,206	829	35.1
700	595	1,410	709	40.9
800	680	1,605	623	46.8
900	765	1,806	553	52.6
1,000	850	2,000	500	58.5
2,000	1700	3,830	261	117
3,000	2550	5,670	176	175
4,000	3400	7,500	133	234
5,000	4250	9,240	108	292
6,000	5100	10,950	91	351
7,000	5950	12,650	79	409
8,000	6800	14,340	69	468
9,000	4650	16,000	62	526
10,000	8500	17,600	56	585

MRO-2.5-500 DRAWING

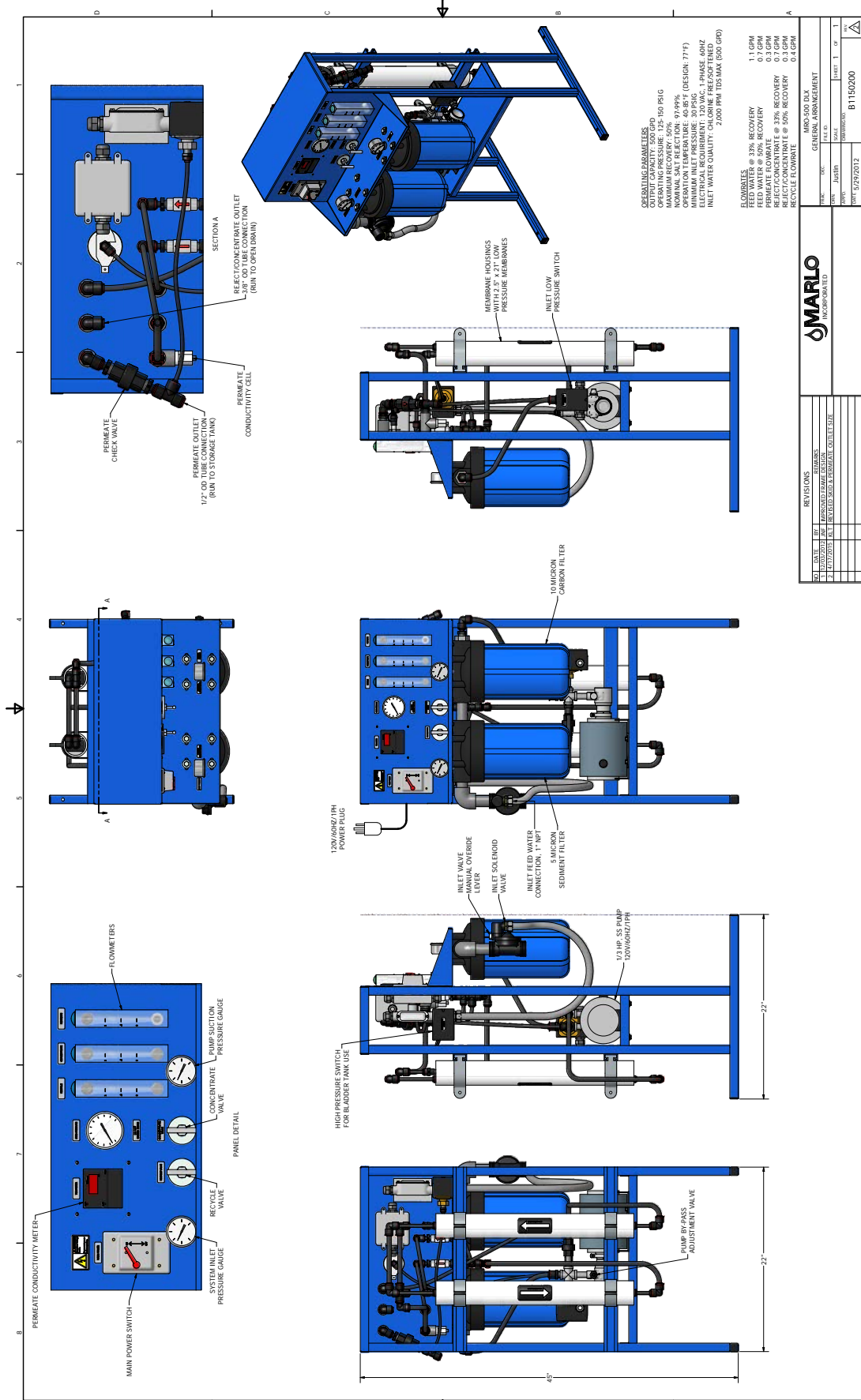

WIRING DIAGRAM

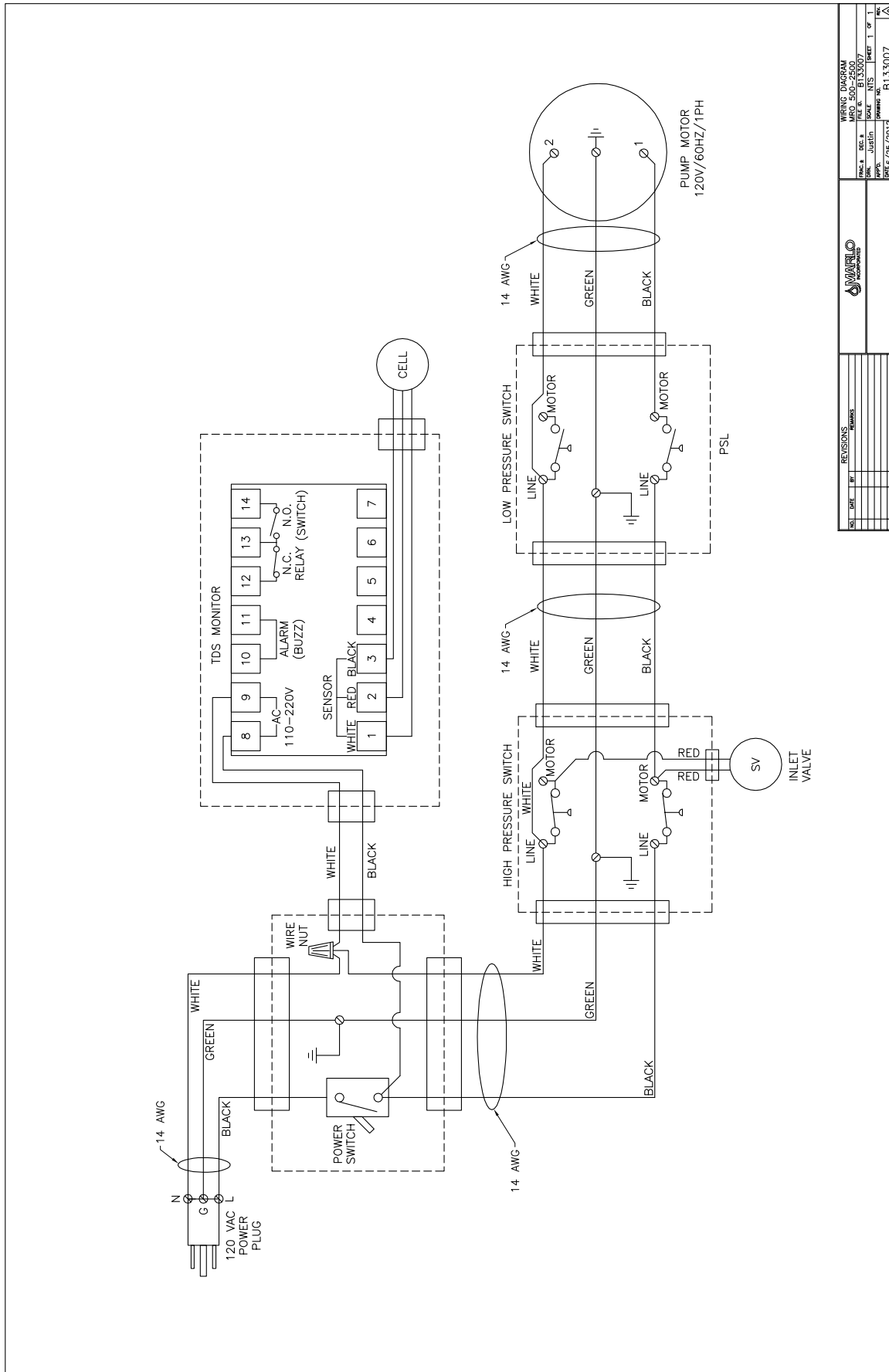

REV.	DATE	BY	REVISIONS

WIRING DIAGRAM	MRO 500-2500
DATE: 06/25/2012	DESIGNER: Justin
PROJECT: MRO 500-2500	DRAWN BY: Justin
REV: 1	DATE: 06/25/2012

INSTALLATION / OPERATION MRO-2.5 500 WITH BLADDER TANK

Installation

1. Locate bladder tank on suitable flat surface. Attach manifold assembly as shown below. Precharge bladder tank to 15psi air pressure using the schrader valve on the top of the tank.
2. Connect pressurized permeate outlet to process piping (pipe material to be suitable for use with ro water). Be sure to support manifold piping with hangers to eliminate any piping stresses.
3. Connect supplied 3/8" tubing from the ro unit permeate outlet to the check valve on the manifold as shown below.

Operation

1. The ro unit with permeate pressure switch option incorporates a pressure switch factory piped and wired to the RO. The pressure switch is set at 20psi cut in and 40psi cut out. The RO unit will automatically run when the pressure in the bladder tank falls below 20 psi and it will cut-off when the pressure rises to 40 psi.
2. The operator can test the pressure switch operation by closing the isolation valve on the manifold. The pressure in the line should rise to 40 psi and the ro should shut-off. Opening the isolation valve will relieve pressure and the RO should start running.

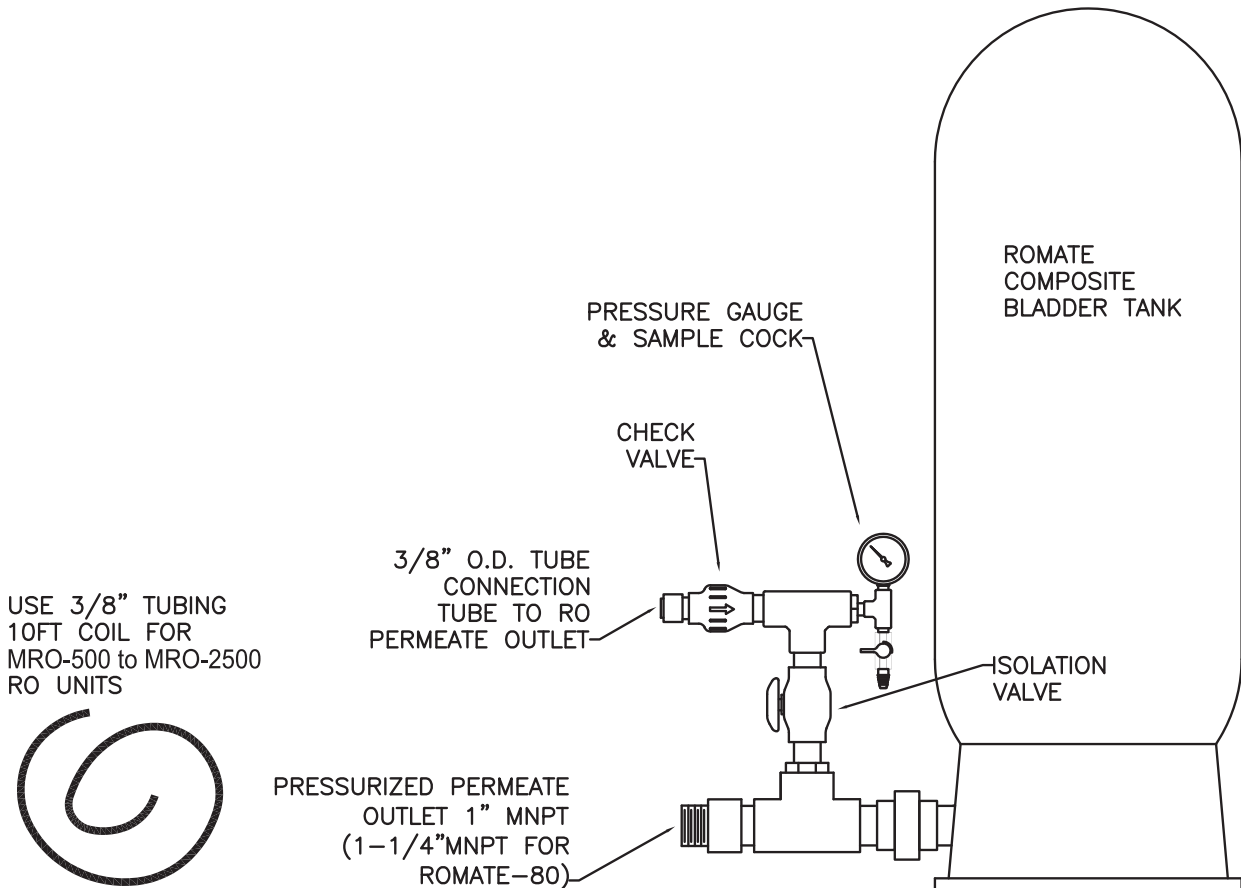

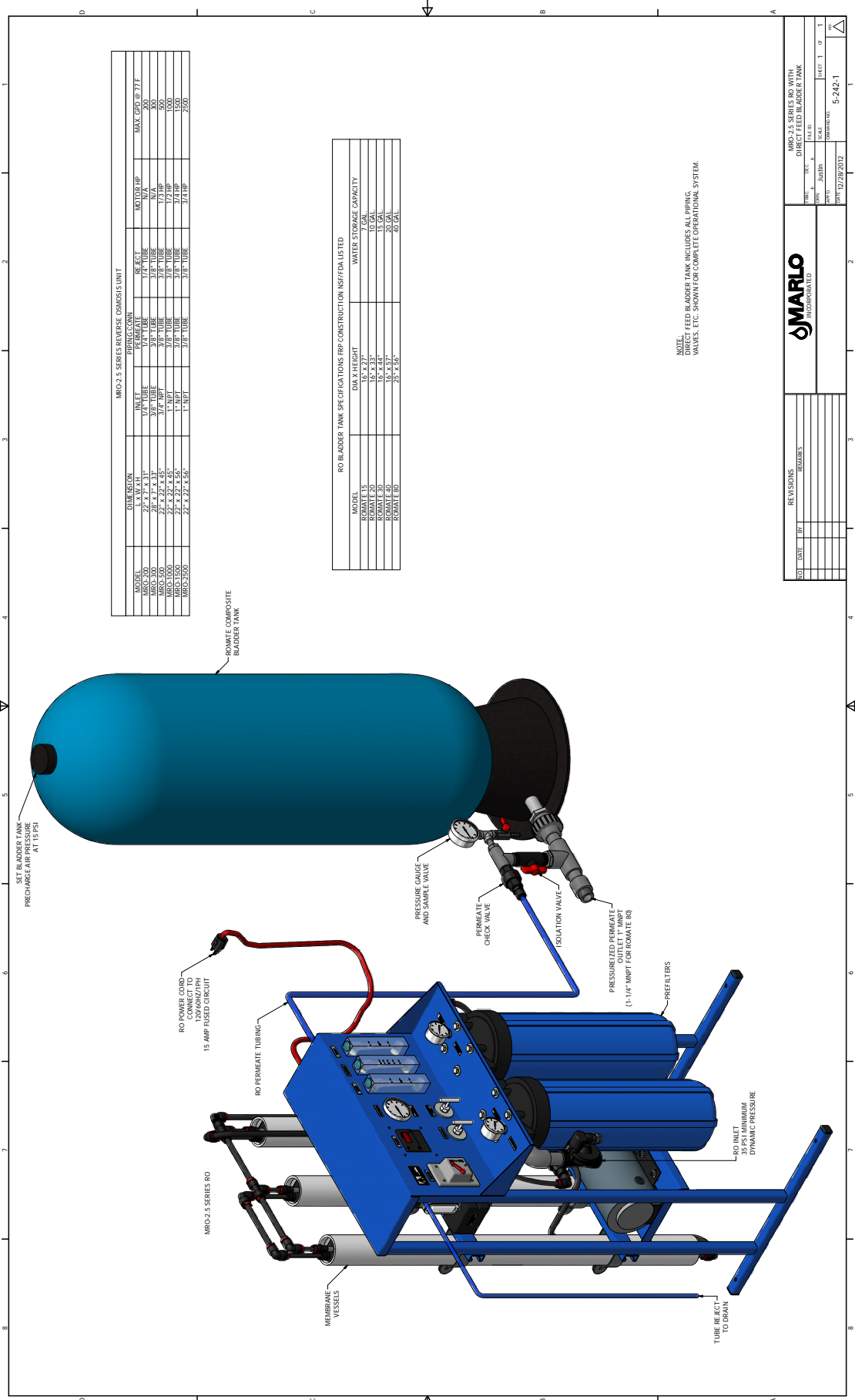

MRO-2.5 SERIES REVERSE OSMOSIS UNIT

MODEL	DIMENSION	INLET	PIPE/CONE	REJECT	PERMEATE	MAX. GPD @ 7.5 FT
MRO-200	22" x 7.2" x 31"	1/4" TUBE	1/4" TUBE	1/4" TUBE	N/A	300
MRO-300	28" x 7.2" x 31"	3/8" TUBE	3/8" TUBE	3/8" TUBE	N/A	500
MRO-400	22" x 7.2" x 45"	1" MPT	3/8" TUBE	3/8" TUBE	1/2" TUBE	1000
MRO-1000	22" x 7.2" x 55"	1" MPT	3/8" TUBE	3/8" TUBE	1/2" TUBE	1000
MRO-1500	22" x 7.2" x 55"	1" MPT	3/8" TUBE	3/8" TUBE	1/2" TUBE	1500
MRO-2500	22" x 7.2" x 55"	1" MPT	3/8" TUBE	3/8" TUBE	1/2" TUBE	2500

RO BLADDER TANK SPECIFICATIONS RFP CONSTRUCTION NSF/IDA LISTED

MODEL	DIA X HEIGHT	WATER STORAGE CAPACITY
ROMATE 15	16" x 27"	7 GAL.
ROMATE 30	16" x 44"	15 GAL.
ROMATE 40	16" x 57"	20 GAL.
ROMATE 80	25" x 56"	40 GAL.

NOTE:
DIRECT FEED BLADDER TANK INCLUDES ALL PIPING,
VALVES, ETC. SHOWN FOR COMPLETE OPERATIONAL SYSTEM.

REV. NO.		DATE		BY		REVISIONS	
MARLO INCORPORATED							
MRO-2.5 SERIES RO WITH DIRECT FEED BLADDER TANK				SHEET 1 OF 1			
DATE: 02/28/2012				DRAWING: 5-242-1			

INSTALLATION / OPERATION MRO-2.5 500 WITH ATMOSPHERIC STORAGE TANK WITH REPRESSURIZATION PUMP

Installation

1. Locate bulk storage tank on suitable flat surface. Connect repressure pump to storage tank with supplied fittings as shown below. Pipe tank overflow to drain.
2. Connect pump pressurized outlet to process piping (pipe material to be suitable for use with RO water).
3. Connect 3/8" tubing from the ro unit permeate outlet to the bulk storage tank as shown below.
4. Wall mount the float switch GFI receptacles and have a qualified electrician run power to the receptacles following local electrical codes and the wiring diagram shown below.
5. Plug the RO unit into the top float switch gfi receptacle. Plug the repressure pump into the bottom float switch GFI receptacle. Do not plug any other devices into these dedicated receptacles.

Operation

1. The RO unit will automatically run based on the position of the top float switch. The length of the float switch cable inside the tank determines the on/off water level. As the cable length increases, the on/off differential increases. Typical length is 12"
2. The low level float switch operates in the same manner. The repressure pump will not run unless the water level in the tank activates the low level float switch. Typical length of this float switch is also 12". The pump will automatically activate to maintain 30 psi on the discharge of the pump. Maximum flow is 20 gpm.

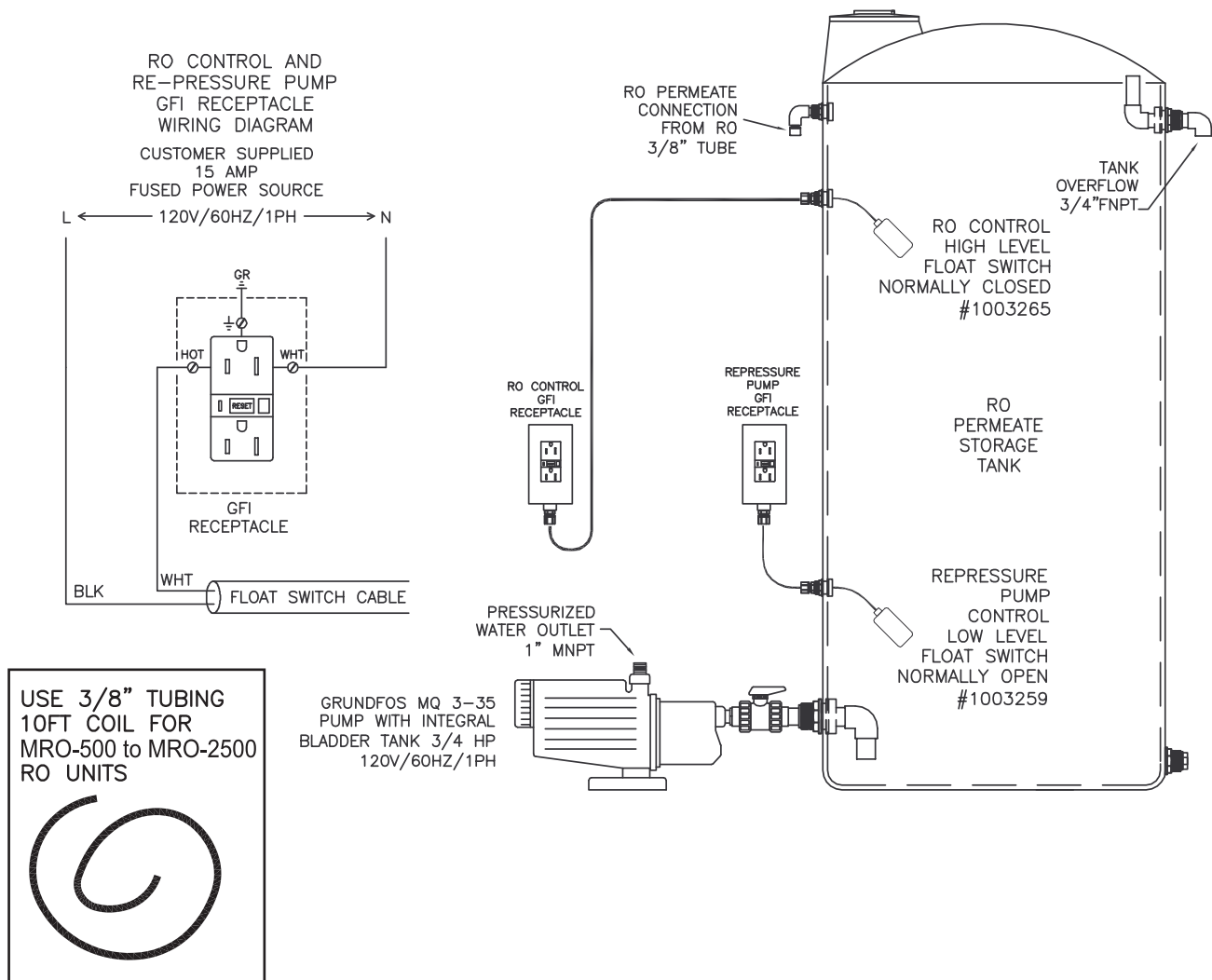

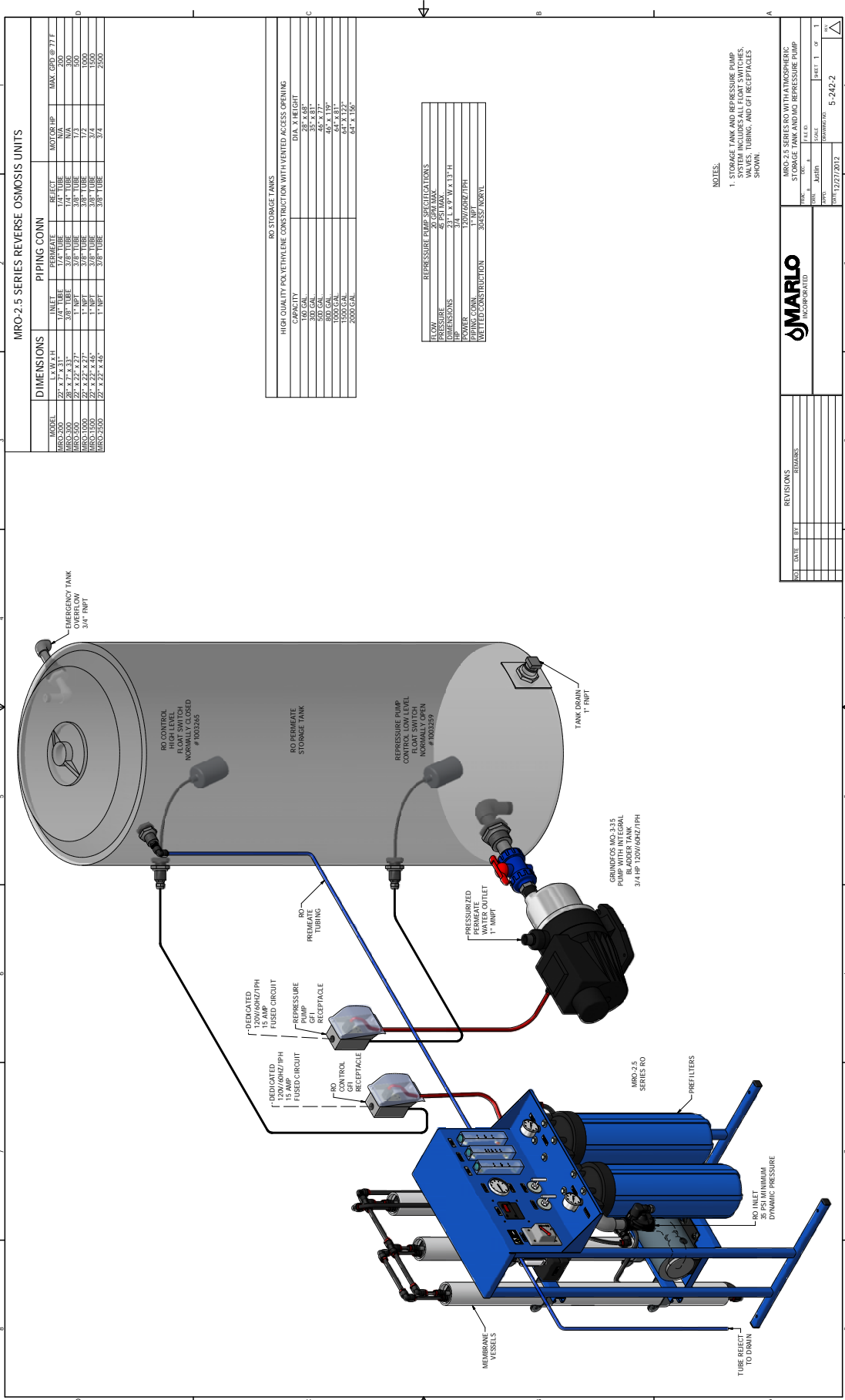

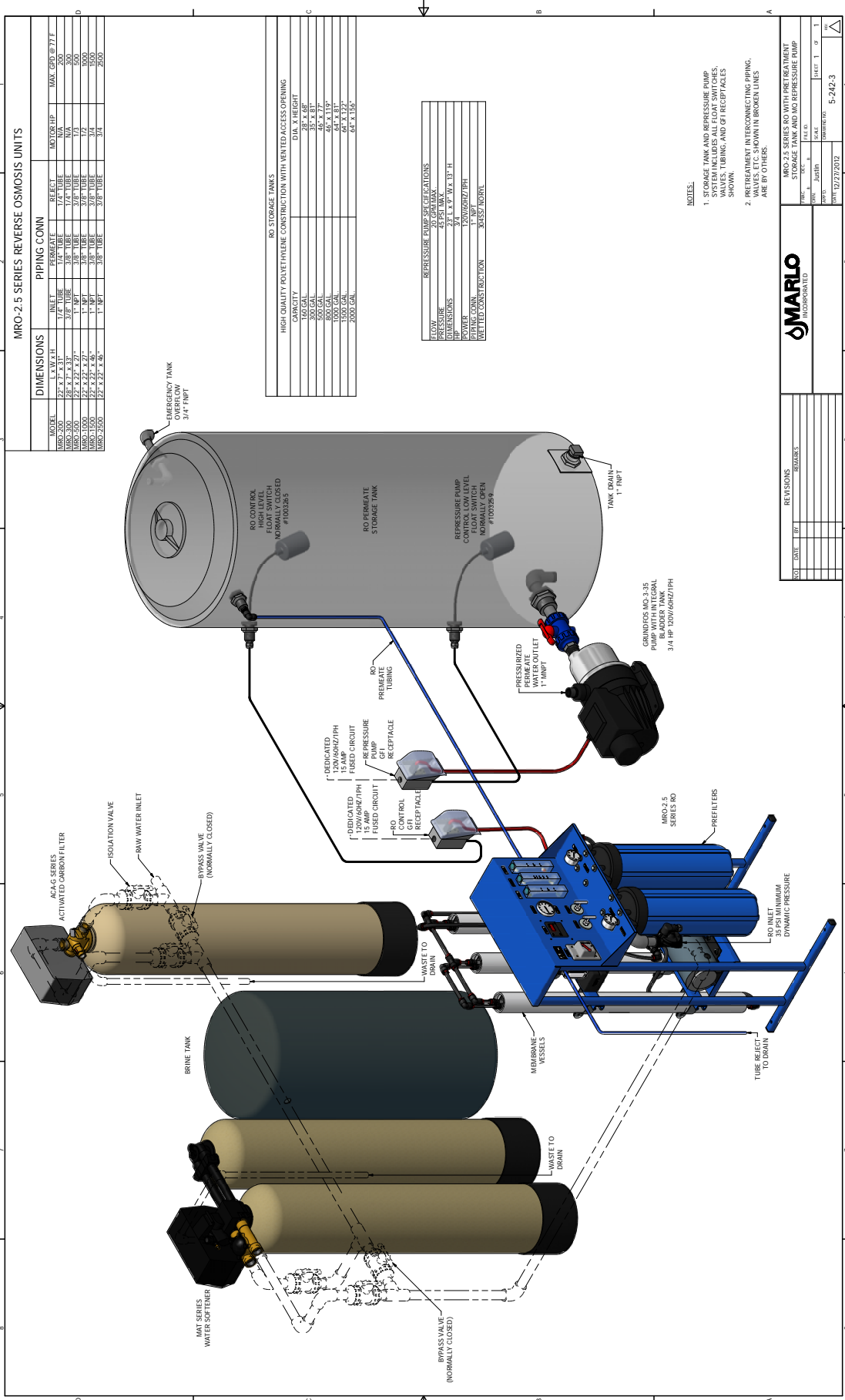

MRO-2.5 SERIES REVERSE OSMOSIS UNITS

MODEL	DIMENSIONS		PIPING CONN		MOTOR/HP	MAX. CAP. @77°F
	L" W" X H"	INLET	PERMEATE	REJECT		
MRO-250	22" x 27" x 46"	1" NPT	3/8" TUBE	3/8" TUBE	N/A	500
MRO-500	22" x 27" x 46"	1" NPT	3/8" TUBE	3/8" TUBE	N/A	500
MRO-1000	22" x 27" x 46"	1" NPT	3/8" TUBE	3/8" TUBE	N/A	1000
MRO-1500	22" x 27" x 46"	1" NPT	3/8" TUBE	3/8" TUBE	N/A	1500
MRO-2500	22" x 27" x 46"	1" NPT	3/8" TUBE	3/8" TUBE	N/A	2500

RO STORAGE TANKS	
CAPACITY	20 GALS
CONSTRUCTION	HIGH QUALITY POLYETHYLENE CONSTRUCTION WITH VENTED ACCESS OPENING
DIAMETER	24" X 48"
HEIGHT	35" X 81"
WEIGHT	46" X 119"
LENGTH	64" X 81"
WIDTH	64" X 81"
DEPTH	64" X 156"

REVERSE PUMP SPECIFICATIONS	
FLOW	20 GPM MAX
HEAD	23.1' X 9" W X 13" H
DIMENSIONS	23.1' X 9" W X 13" H
POWER	3/4 HP @ 120V/60Hz/1PH
WARRANTY	1" NPT
CONSTRUCTION	305SS MOTOR

NOTES:

1. STORAGE TANK AND REVERSE PUMP MUST BE INSTALLED ON A LEVEL SURFACE. VALVES, TUBING, AND GFI RECEPTACLES SHOWN.
2. PRETREATMENT INTERCONNECTING PIPING, VALVES, ETC. SHOWN IN BROKEN LINES ARE BY OTHERS.

REVISIONS

NO.	DATE	BY	REVISIONS
1			

MARLO INCORPORATED

MRO-2.5 SERIES RO WITH PRETREATMENT STORAGE TANK AND RO REVERSE PUMP

Scale: 1/4" = 1'-0"

Sheet: 1 of 1

Revised: 5-24-23

Drawn: Justin

Part: 52-232012

MRO 500 TUBING DIAGRAM

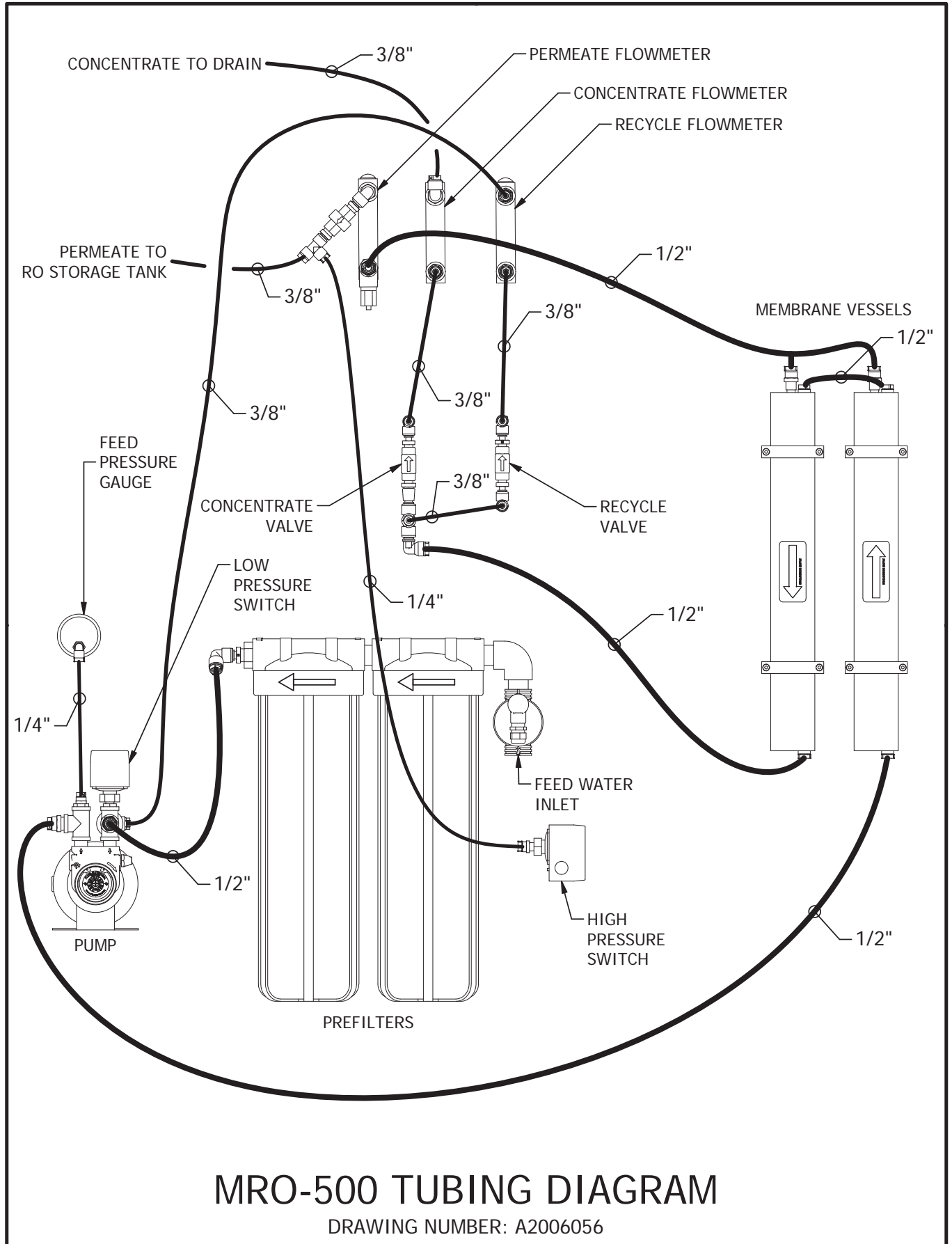

MRO-500 TUBING DIAGRAM

DRAWING NUMBER: A2006056

MRO 500 SPARE PARTS LIST (front views)

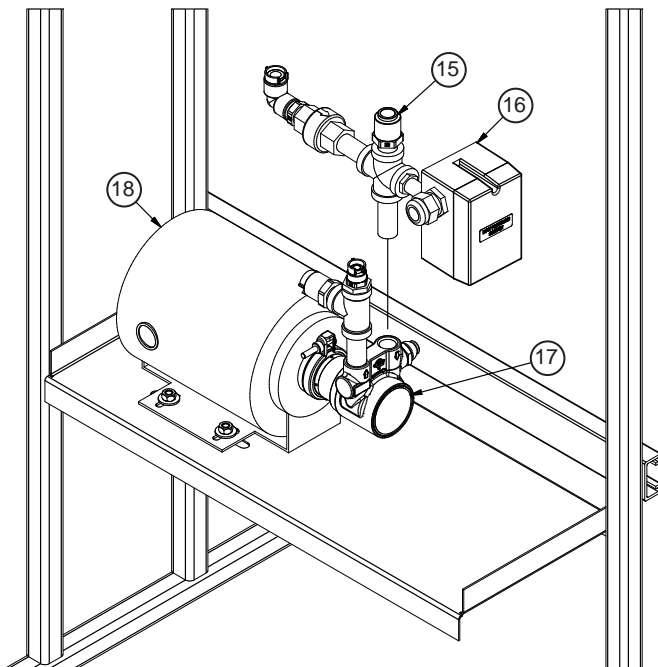
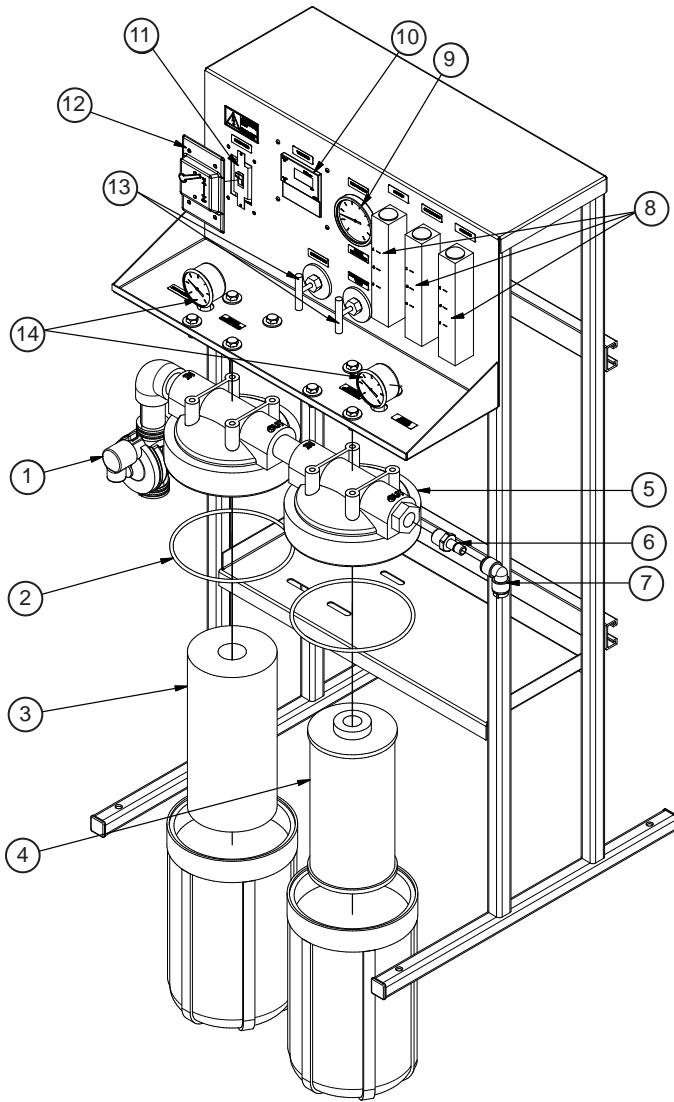

Item Number	Part Number	Description	Qty.
1	A2221056	VALVE SOLENOID 1 2WAY NC 120V W/MO - INLET	1
2	A2077152	O-RING FOR #20BB HOUSING(151122)	2
3	A2112150	FILTER 5 MIC 10 INCH BB PRE-FILTER	1
4	A2112027	CARBON FILTER - BB	1
5	A2403010	HOUSING #10 BIG BLUE 1 W/O PR	2
6	A2412166	ADAPTER 1/2STEM X 1/2MNPT PP BL UV	4
7	A2129129	ELBOW UNION 1/2T PP BL UV	1
8	A2426233	ROTAMETER 1GPM 1/2 PAN-ELMNT	3
9	A2141111	PRESSURE GAUGE 2.5 160 PSI SS MEMBRANE FEED	1
10	A2331099	TDS METER CONTROLLER PS-100	1
11	A2203143	SWITCH 20AMP DOUBLE POLE IVORY	1
12	A2103178	COVER WEATHERPROOF TOGGLE	1
13	A2555028	RECYCLE / CONCENTRATE VALVE	2
14	A2141146	PRESSURE GAUGE 2" 0-100 PSI	2
15	A2129151	CONN MALE 1/2T X 3/8MNPT BLK PP	2
16	A2203142	INLET PRESSURE SWITCH	1
17	A2226538	PUMP CARB SS PA411 2.3GPM	1
18	A2085085	MOTOR CARB 1/3HP 48Y 120VAC	1

MRO 500 SPARE PARTS LIST CONTINUED (rear views)

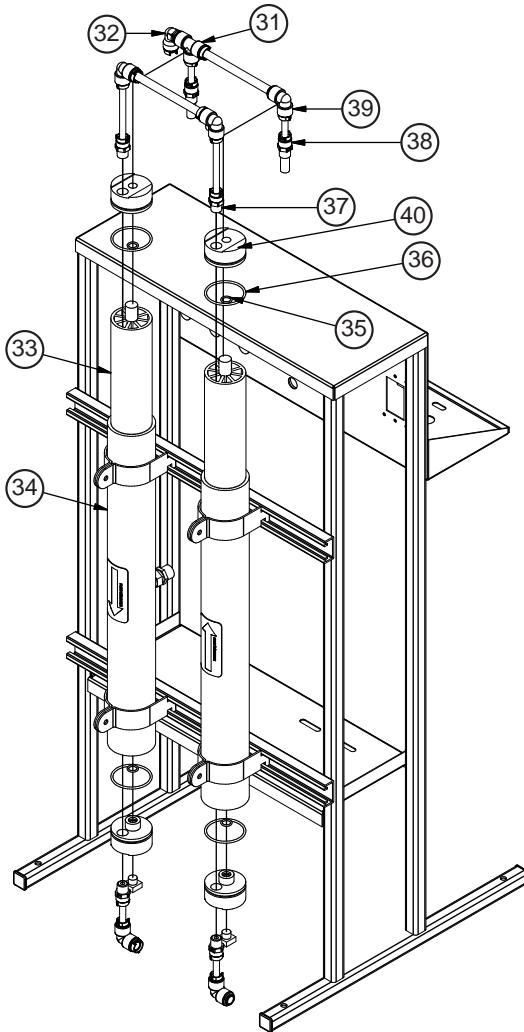
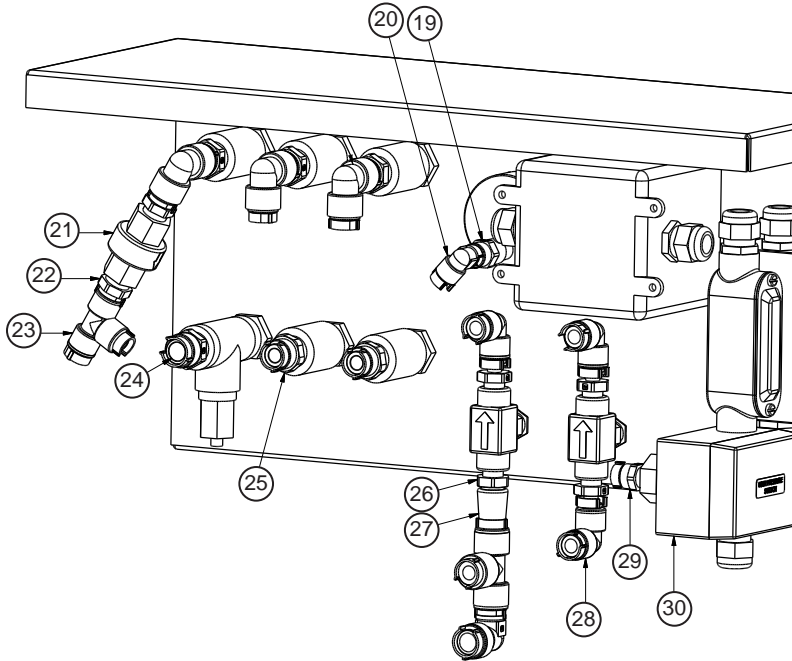

Item Number	Part Number	Description	Qty.
19	A2129152	CONN FEMALE 1/4T X 1/4FNPT BLK PP	1
20	A2129149	ELBOW 1/4TUBE X 1/4STEM BLK PP	1
21	A2247097	VALVE CHECK 3/8FNPT POLYPRO SMC	2
22	A2412182	ADAPTER 3/8STEM X 3/8MNPT BLK PP	3
23	A2129147	TEE TUBE UNION 3/8T X 3/8T X 1/4T BLK PP	1
24	A2412164	ADAPTER 1/2T X 1/2MNPT PP BL UV	1
25	A2129154	CONN MALE 3/8T X 1/2MNPT BLK PP	2
26	A2412181	ADAPTER 3/8STEM X 1/4MNPT BLK PP	4
27	A2363320	ADAPTER 1/2STEM X 3/8MNPT PP BL UV	1
28	A2129141	ELBOW TUBE UNION 3/8T BLK PP	4
29	A2412163	ADAPTER 1/4T X 1/4MNPT PP BL UV	2
30	A2203141	PRESSURE SWITCH FOR BLADDER TANK CONTROL	1
31	A2129148	TEE TUBE UNION 1/2T X 1/2T X 3/8T BLK PP	2
32	A2129150	ELBOW 1/2TUBE X 1/2STEM BLK PP	2
33	A2571067	2.5" x 21" CSM MEMBRANE	2
34	A2572076	VESSEL 300PSI 2.5 X 21 WC	2
35	A2077298	SEAL PERM PORT 4" END CAP WC EPDM 512(WPV-10178)	4
36	A2077276	HEAD SEAL FOR 2.5" WC ENDCAP	4
37	A2129153	CONN MALE 3/8T X 3/8MNPT BLK PP	4
38	A2129144	CONN FEMALE 3/8T X 1/4FNPT BLX PP	2
39	A2129142	ELBOW TUBE UNION 1/2T X 3/8T BLK PP	8
40	A2287212	ENDCAP 2.5" WC 3/8 X 1/4	4

TROUBLESHOOTING

If the system production declines or the system stops working, check the mechanical components for any visual problems. Listed below are the items to check for any visual problems. Listed below are the items to check for two of the most commonly encountered problem conditions: Low system pressure and abnormal permeate flow. Also refer to the reverse osmosis troubleshooting matrix on the next page.

LOW SYSTEM PRESSURE

Low system pressure occurs when sufficient feed water pressure and flow are not obtained. This causes the high-pressure reverse osmosis pump to cavitate. Failure to provide the proper feed will result in lower system pressure that may result in low production and poor rejection. Check the following components:

1. **Pump:**
Isolate the pump and determine how much pressure can be achieved. This can be determined by checking the pump discharge pressure gauge at this point. If the system is not equipped with this gauge, disconnect the hose that runs from the pump to the pressure vessel. Install a pressure gauge. The pressure of the pump must reach at least 190 psi when the flow is restricted.
2. **Pre-Filter:**
Check the differential in the pre-filter gauges to determine if the filter needs to be replaced. If the system is not equipped with these gauges, examine the pre-filter cartridge to make sure that it is not clogged and does not restrict feed flow to the pump. Replace, if necessary.
3. **Low Feed Water Flow Rate:**
Determine that the system is getting a sufficient volume of feed water. Disconnect the feed water hose from the system and place it in a one gallon bucket. Measure the time it takes to fill the bucket to determine the feed flow. (Feed flow is measured in gallons per minute, so divide 1 gallon by the time in minutes to obtain the flow rate). Refer to the System Specifications for the required feed flow.
4. **Inlet Solenoid Valve:**
Feed water enters the system through an automatic solenoid shut-off valve, which is normally closed. Ensure that the solenoid opens when the reverse osmosis pump starts. The system can be operated without the solenoid for troubleshooting. Remove the solenoid to see if it is contributing to the problem. Normally, cleaning the solenoid diaphragm will correct any malfunction of the solenoid.
5. **Electric:**
Check to ensure that there are no electrical fuses blown and that all electrical connections are secure. Use a voltmeter to verify that the motor is getting sufficient power.
6. **Pressure Gauge:**
Check for foreign matter on the gauge fitting. Remove any visible matter and replace the fitting. Verify that the tube is not pushed too far inside the fitting. This could restrict flow and cause an inaccurate display. If the fitting and tube are fine and the pressure gauge is still malfunctioning, the gauge should be replaced.
7. **Concentrate Control Valve:**
The concentrate control valve may have a tear in the diaphragm. Remove the valve, inspect the diaphragm, and replace if necessary.
8. **Motor:**
The motor may not be drawing the correct current. Use a clamp-on amp meter to check the current draw.
9. **Leaks:**
Check the system for leaks, as this can result in low pressure.

ABNORMAL PERMEATE FLOW

Permeate flow should be within 15% of the rated production, after correcting the feed water temperatures above or below 77°F. Check your permeate flow meter to determine the permeate flow rate. If the system does not have a permeate flow meter, measure the time it takes to fill a 1 gallon container then calculate the permeate flow rate at gallons per minute or gallons per day.

NOTE: To determine the temperature correction factor, locate the Temperature Correction Table in this User's Manual and follow the directions.

1. Causes of Low Permeate Flow:
 - Cold Feed Water
 - Low Operating Pressure
 - Defective Membrane Brine Seal
 - Fouled or Scaled Membrane
2. Causes of High Permeate Flow:
 - Defective Product Tube O-Rings
 - Defective or Oxidized Membrane
3. Causes of Poor Permeate Quality:
 - Low Operating Pressure
 - Defective Product Tube O-Rings
 - Defective or Oxidized Membrane
 - Fouled or Scaled Membrane

Reverse Osmosis System Troubleshooting

Symptoms			Location	Possible Causes	Verification	Corrective Action
Salt Passage	Permeate Flow	Pressure Drop				
Normal to Increased	Decreased	Normal to Increased	Predominately First Stage	Metal Oxide Fouling	Analysis of Metal Ions in Cleaning Solution.	Improve pretreatment to remove metals. Clean with Acid Cleaners.
Normal to Increased	Decreased	Increased	Predominately First Stage	Colloidal Fouling	SDI Measurement of Feed Water.	Optimize pretreatment for colloid removal. Clean with high pH anionic cleaners.
Increased	Decreased	Increased	Predominately First Stage	Scaling (CaSO ₄ , CaSO ₃ , BaSO ₄ , SiO ₂)	Analysis of metal ions in cleaning solution by checking LSI of reject. Calculate max. solubility of CaSO ₄ , BaSO ₄ , SiO ₂ in reject.	Increase acid addition and antiscalant dosage for CaVO ₃ and CaCO ₄ . Reduce recovery. Clean with Acid Cleaners.
Normal to Moderate Increase	Decreased	Normal to Moderate Increase	Any Stage	Biological Fouling	Bacteria count in permeate and reject. Slime in pipes and pressure vessels.	Shock dosage of Sodium Bi-Sulfate. Continuous feed of Sodium Bi-Sulfate at reduced pH. Formaldehyde disinfection. Chlorination and de-chlorination. Replace cartridge filters.
Decreased or Slightly Increased	Decreased	Normal	Any Stage	Organic Fouling	Destructive Element Testing.	Activated Carbon or other pretreatment. Clean with high pH cleaner.
Increased	Increased	Decreased	Most Severe in First Stage	Chlorine Oxidation	Chlorine Analysis of feed water. Destructive element test.	Check Chlorine feed equipment and de-chlorination system.
Increased	Increased	Decreased	Most Severe in First Stage	Abrasion of membrane by Crystalline Material	Microscopic solids analysis of feed. Destructive element test.	Improve pretreatment. Check all filters for media leakage.
Increased	Normal to Increased	Decreased	At Random	O-Ring Leaks, End or Side Seal Leaks	Probe test. Vacuum test. Colloidal material test.	Replace O-Rings. Repair or replace elements.
Increased	Normal to Low	Decreased	At Random	Recovery Too High	Check Flows and Pressure Against Design Guidelines.	Reduce the recovery rate. Calibrate and/or add sensors.

REVERSE OSMOSIS TERMS & DEFINITIONS

Anti-scalant - Chemical treatment added to increase the solubility of sparingly soluble salts. In reverse osmosis (RO) systems CaCO_3 , CaSO_4 , SrSO_4 , BaSO_4 are the most common scaling salts of concern.

Anti-Telescoping Device - (ATD) a hub and spoke shaped device fitted over both the feed and concentrate end of the membrane element. It is designed to prevent the membrane spiral structure from elongating (“telescoping”) due to pressure differential from feed to concentrate. It also provides the groove for the brine seal.

Array - The physical arrangement of the pressure vessels, e.g., 4:3:1 - 3 stages with 8 total vessels. Stage 1 has 4 pressure vessels; stage 2 has 3 pressure vessels and stage 3 have 1 pressure vessel. The reject of each stage is the feed stream for the next successive stage.

Brackish Water - Water of Total Dissolved Solids having TDS levels up to 10,000 mgfL or PPM.

Brine Seal - Plastic or rubber devices that seal the outside of one end of a spiral wound membrane element against the wall of the RO housing. These devices prevent bypassing of feed water around the element.

Chlorine Tolerance - Chlorine will oxidize the surface of thin film composite (TFC) polyamide membranes causing the membrane to lose its ability to repel or reject salts. Thin film membranes can briefly tolerate chlorine but the damage is immediate and cumulative. Maximum acceptable level of chlorine for TFC membranes is 0.1-PPM. Tolerance is defined by this relationship - 0.1-PPM chlorine for 1,000-hours operation. Doubling the chlorine will halve the operating time. Ultimately, chlorine levels in RO feed water should be “not detectable”.

Conversion or Recovery - the percentage of the Feed water which is converted into permeate, sometimes referred to as “recovery”.

Cross Flow Separation - Filtration process by which a pressurized feed water stream flows parallel to a porous membrane gradually becoming a concentrate stream of contaminants as pure water stream passes through the membrane. Contaminants are not collected on porous membrane but are continuously flushed away. Cross flow separation differs from Dead Head Separation in that it has two discharge streams.

Dead Head Separation - Filtration process by which a pressurized feed water stream is directed entirely through a porous filter media. The contaminants are collected both on surface of or within porous structure of filter media. The filter media is replaced when resistance to flow becomes excessive. (Exceeds 20-PSI)

Elements - Often referred to as a spiral wound module, elements are the physical devices that house the membrane layers. Large RO systems can have up to six elements per membrane housing.

End Cap - A disc shaped component placed into end ports of membrane housing. The end cap serves as both a closure and pathway for concentrate and permeates flow to pass through membrane housing. O-rings provide a slip seal between end cap perimeter and membrane housing end port.

Feed Spacer - a plastic fine mesh netting located between membrane leaves. The feed spacer forms a flow channel for the feed water to pass through. Its purpose is to generate turbulence, breaking down boundary layers close to the membrane film helping to reduce scaling and fouling potential.

Feed Stream - Flow into the first stage of an RO system. The feed stream is separated into a permeate or product stream and a concentrated or brine stream. Feed Stream = Permeate + Concentrate.

Flux - Water Flux - Typically expressed as volume per area per unit of time, flux is used to express the rate at which water permeates a membrane. Typical units are gallons per square foot per day (i.e. GFD or GSFD). The flux of a membrane is directly proportional to temperature and pressure. As a rule of thumb, flux decreases 1.5% per 1 Degree F.

Flux - Salt Flux - Amount of TDS passed through a given area of membrane per unit of time. It is important to remember that Salt flux is a function of concentration gradient and not driving pressure. Therefore with increasing driving pressure, the concentration of salts in the permeate decreases due to constant salt leakage (e.g., milligrams) and increased water flux (e.g., gallons). The net effect of increased drive pressure is to dilute a constant amount of salt with more pure water (permeate).

Hydrolysis - Chemical breakdown of a membrane from exposure to temperature or oxidants (e.g. chlorine, ammonia, potassium permanganate). Hydrolysis causes increased salt leakage (i.e. elevated permeate conductivity) and a lower feed pressure requirement.

REVERSE OSMOSIS TERMS & DEFINITIONS (continued)

Inter-connector - Tubular device used to attach Product Collection Tube of multiple RO membranes together providing a means to install multiple membranes into one membrane housing. The device employs o-rings on each end to provide a slip seal between Product Collection Tube of adjacent membranes.

Langelier Saturation Index or LSI - Measurement of CaCO₃ potential of feed water and is used as a key performance indicator in the management of reverse osmosis systems. A positive Langelier Saturation Index indicates that CaCO₃ will scale membrane surface. A negative LSI indicates that the water is corrosive and less likely to scale membrane surface.

Membrane - An RO membrane is a semi-permeable film-like material, through which mineral free water passes relatively quickly, while other substances cannot or do so relatively slowly. Membranes provide the barrier layer or interface for cross flow separation. Membranes are thin, porous material constructed of organic polymer (e.g., cellulose acetate, polyamide and charged polysulfone). RO membranes will typically reject contaminants with molecular weights greater than 200.

Membrane Housing - A tubular device containing the membrane elements. For spiral wound elements the pressure vessel often is referred to as the pressure tube and can contain up to six membrane elements. The housing is designed to withstand at least 300-PSI operating pressure.

Multiple Pass - See "Staging"

Net Driving Pressure - NDP, the difference between the feed pressure and the osmotic pressure. It is the measure of the actual driving pressure available to force the water through the membrane. As net driving pressure increases, the flux increases proportionally when all other factors are held constant.

Normalized Permeate Flow - NFP is a calculation that allows the comparison of a measured permeate flow rate to a standard or start up condition. Permeate flow is a function of Net Driving Pressure (NDP), temperature and membrane condition. By normalizing measured permeate flow for observed NDP and temperature, a measure is obtained that can be used to compare the condition of the membrane to original start up conditions. A decrease in NPF of 10-15% indicates that membrane cleaning is required.

Organic Fouling - Biomass retention or growth inside the membrane element. Fouling primarily occurs on membranes located in the first membrane housing. Symptoms of scaling are "membrane discoloration", "low flow", "and high pressure differential in concentrate stream". Low pH based chemical cleaning breaks the bridge between the organics and the membrane immediately followed by high Ph cleaning to lift the foulants off the membrane surface. Prevent organic fouling by pre-treating feed water.

O-Rings - Provide water tight seal between the permeate water tube inter-connectors of adjacent elements. They prevent the intrusion of high pressure feed water (poor quality) into the low pressure permeate water (good quality). Damaged O-ring results in higher salt concentration of permeate in that section of the system. Refer to "Probing Membrane Housing". Provide water tight seal between end cap and membrane housing port.

Osmotic Pressure - Pressure required preventing the flow of water across a semi-permeable membrane separating two solutions having different ionic strengths. For RO systems it is osmotic pressure that has to be overcome in order to produce permeate. A "rule of thumb" is for every 100 mg/l of TDS difference between feed and permeate, 1-PSI of osmotic pressure exists.

Permeate - Often referred to as "product," permeate is the portion of the feed water stream water which passes through the membrane. $\text{Permeate Flow} = \text{Feed Water Flow} - \text{Concentrate Flow}$

Permeate Carrier - Porous material sandwiched between layers of membrane film. This structure carries permeate water from the membrane film surface to the permeate tube.

Permeate Collection Tube - A perforated tube, in center of spiral wound membrane structure, which collects permeate water and upon which the membrane films are attached. The ends of the permeate tube are fabricated to allow coupling with other permeate tubes using inter-connectors with o-rings. These allow permeate water to travel from element to element, and finally to the end cap of a membrane housing.

Probing Membrane Housing - A diagnostic procedure used to identify a failure of membrane(s) or o-ring joints within single membrane housing. Probing involves inserting a flexible tube into the membrane housing permeate port while RO is in operation. The tube is inserted to select locations within the permeate collection tubes of each membrane. Permeate from that location is collected and diverted to a portable conductivity monitor. Extreme variations in conductivity readings indicate faulty membrane or o-ring seal(s).

REVERSE OSMOSIS TERMS & DEFINITIONS (continued)

Product Collection Tube - A perforated tube, in center of spiral wound membrane structure, which collects product water and upon which the membrane films are attached. The ends of the Product Collection Tube are fabricated to allow coupling with other Product Collection Tubes using inter-connectors with o-rings. These allow product water to travel from element to element, and finally to the end cap of membrane housing.

Product Channel Spacer - Also known as a Permeate Water Carrier. In the construction of a membrane element, the product channel spacer is placed between two adjacent layers of the flat sheet membrane. This spacer is a knit fabric called Tricot and is used to prevent the membrane from closing off on itself under the high pressure of operation. Permeate water will flow in a spiral path through the product channel spacer into the product collection tube.

Recovery or Conversion - The percentage of the feed water converted into permeate. (Sometimes referred to as "conversion").

Reverse Osmosis - A membrane separation process, wherein purified water (permeate) is extracted by using synthetic membrane materials which are permeable to low molecular weight water molecules but relatively non-permeable to high molecular weight contaminants.

Salt Passage - The quantity of salt, as a percentage, which passes through the membrane into to the permeate stream. Salt passage is a function of temperature, velocity and concentration gradient (i.e., concentration of salt in the concentrate versus the permeate).

Salt Passage = 1 - Salt Rejection

Salt passage = (TDS-product) / (TDS-Feed) x 100

Salt Rejection - The quantity of salt removed from the feed water stream as a percentage.

Salt Rejection = 1 — Salt Passage

Salt Rejection = (TDS Feed - TDS-product) / (TDS Feed) x 100

Scaling - A gradual deposition of calcium carbonate (CaCO₃) onto the surface of membrane film. Scaling primarily occurs on membranes located in the fast membrane housing. Symptoms of scaling are "poor salt rejection", "low permeate flow", "high pressure differential in concentrate stream". Acid based chemical cleaning will reduce scaling damage. Prevent scaling by pre- treating feed water.

Shimming - placement of plastic or stainless steel washers over the permeate collection tube of a membrane or permeate port of a membrane housing end cap. Shims take up excess space inside membrane housing keeping the membrane(s) from shifting when RO operation starts and stops. Shifting membrane(s) will cause premature wear of o-ring joints.

Silt Density Index (SDI) - Empirical test used to characterize the fouling potential of a feed water stream. Test is based on measuring the rate of plugging a 45 micron filter using a constant 30 psig feed pressure for specified period of time. SDI-15 refers to a silt density index test which is run for 15 minutes. Typically spiral wound systems require an SDI < 5 and hollow fiber systems require an SDI < 3. Most deep well waters have an SDI of 3 and most surface water have SDI's greater than 6.

Thin Film Composite (TFC) - RO membrane composed of and manufactured as three layers bonded together. The two base layers of the asymmetric design have a thin skin (3rd) layer of either polyamide or charged polysulfone deposited on the surface. The thin film is the salt rejecting layer where the two base layers provide a porous structure whose function is strength.

Spiral Wound Element - A membrane configuration which is comprised of "flat sheet membrane-permeate channel spacer - flat sheet membrane - feed channel spacer" combinations rolled up around a product collection tube.

Staging - Reject Staging refers to a technique where the reject from one group of RO pressure vessels becomes the feed stream of a second group of RO pressure vessels. Reject staging is used to increase the recovery of water.

A one stage system typically could recover 50 - 60% of the feed water stream.

A two stage system typically could recover 75 - 80% of the feed water stream.

A three stage system typically could recover greater than 85% of the feed water stream.

Product Staging referred to as "multiple pass", is a technique where the product of the first group of RO pressure vessels becomes the feed water stream for a second stage. Product staging is used to increase the quality of the product water.

REVERSE OSMOSIS TERMS & DEFINITIONS (continued)

Sulfate Fouling - Barium Sulfate scale on a membrane or membrane housing feels like fine grit sand paper. This abrasiveness damages the membrane surface during system operation. When the system is started and stopped, the feed spacer material shifts slightly. This shifting allows the embedded barium sulfate scale to scratch the membrane surface causing permanent damage and results in a loss of salt rejection.

Telescoping - A damaging condition to membrane element structure caused by excessive pressure differential between feed water pressure and concentrate water pressure. Telescoping causes the membrane layers to elongate towards the down stream side of the element tearing apart the internal structure. The extruded material will appear as a bulge emerging from one end of element shell. The maximum allowable pressure differential for a single 40" long membrane is 10-PSI. Membrane cleaning will reduce excessive differential pressure.

Thrust Support - Device installed in membrane housing between end of membrane element and down stream end cap. The cone shape transfers pressure induced forces from the membrane element directly to the end cap reducing a membrane damaging phenomenon called "telescoping".

Ultra-filtration - Cross flow separation technique used to remove colloidal, very fine particles and macro-molecules from a water stream. Pore sizes in a Ultra-filtration (UF) system range from 0.001 to 0.1 micron. UF membrane systems are characterized by the molecular weight cut-off points (e.g., 3,000, 10,000, 20,000, and 80,000 Daltons). Unlike RO systems, UF does not remove dissolved salts from water.

Ultra-pure Water - Term used to characterize electronic grade process water. Essentially ultra pure water is free of particles, colloids, organic and inorganic contaminants.

COMPONENT DOCUMENTATION

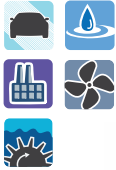

950 SERIES | GENERAL PURPOSE VALVE



DIMENSIONAL DRAWING [INCHES]

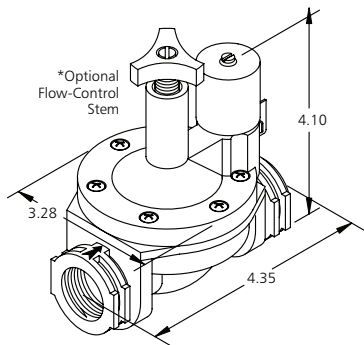

GENERAL INFORMATION

Valve Highlights

- 3/4" and 1" NPT ports
- Normally open and normally closed options available
- Solenoid piloted diaphragm valve
- Manual solenoid override
- Optional flow control feature available

Component Material Combinations

- Brass base nut is standard
- Stainless steel nut is optional
- Copper shading ring in AC units
- Internal components are stainless steel
- Valve body material: Glass filled nylon

Connection Types

- 1/4" spade
- Lead wires
- 1/2" conduit male
- 1/2" conduit female

Electrical Characteristics

- Standard coil class: A (221°F/105°C)
- Power consumption: 5 watts AC, 6 watts DC
- DC voltages: 12, or 24
- AC voltages: 12, 24, 120, or 240
- UL certification on "A" and "I" connection options

Operating Characteristics

- Operating temperature range: Up to 120°F/49°C
- Operating pressure: 10 – 150 PSI
- Max fluid temperature: 180°F/82°C
- 3/4" port max flow: 40 GPM at 150 PSI
- 1" port max flow: 45 GPM at 150 PSI

MODES OF OPERATION

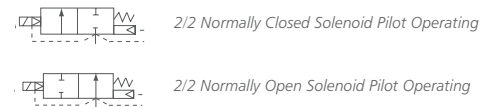

See page 74 for details on modes of operations.

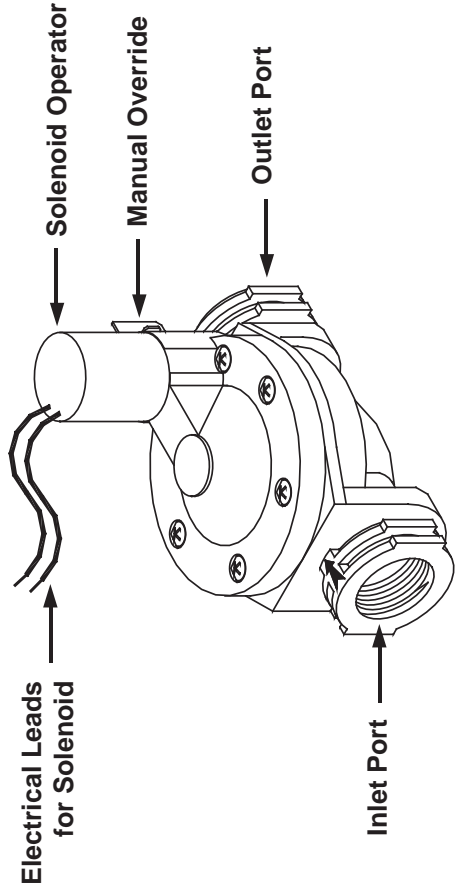

Diaphragm Valve Operation Normally Closed

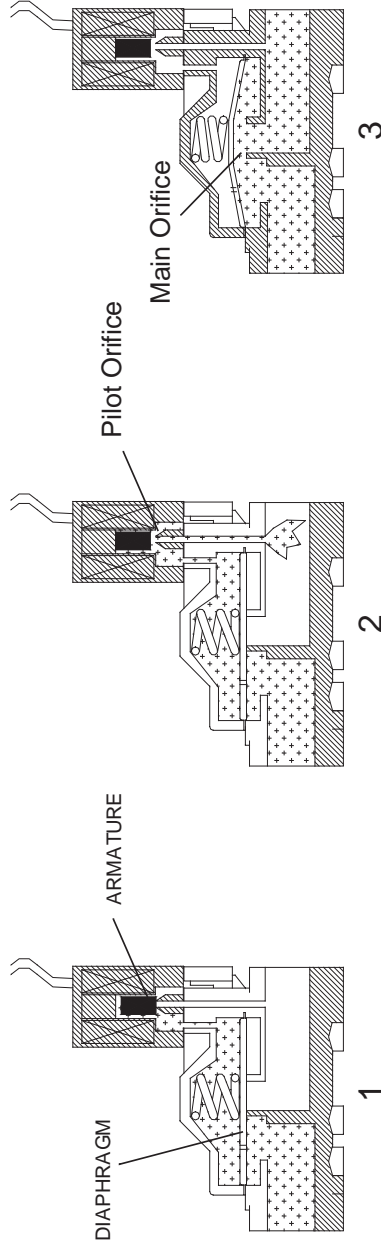

1. Media is supplied to the inlet port creating equal pressure above and below the diaphragm.
2. When voltage is applied to the solenoid, the armature lifts off the pilot seat opening a small passage for the media to exit and relieve pressure above the diaphragm.
3. Diaphragm is then pushed up by incoming pressure, the greater the pressure the higher the diaphragm moves upward, allowing media to flow through the main orifice and exit through the outlet port.
4. The manual override lever (some models) is used to lift the armature without electrical impulse. Flow control stem (some models) limits the height the diaphragm will move.



INSTRUCTION MANUAL

DIRECT DRIVE ROTARY VANE PUMPS MO-CO 30-200, PO 70-400 AND PO 500-1000 SERIES



Find out more

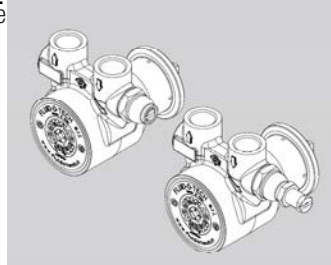

INSTALLATION

The pump has to be installed exclusively by authorized staff. Handle with care.

WARNING

For food applications the pumps (even when NSF listed or WRAS approved) need to be sterilized by circulating water at 80 °C (176 F) for at least 20 minutes. The water used for this operation must not be reused, either during the sterilization or later, but must be discharged.

It is recommended not pulling out the two protection sponge caps placed on the inlet and outlet of the pump before mounting the fittings and the pipes, to avoid the incidental entrance of any solid extraneous object which might damage the internal components of the pump. The Fluid-o-Tech rotary vane pumps look identical in their exterior aspect, within each range, although the flow rates are different. For this reason, when replacing just the pump, it is necessary to check the model of the new pump. Changing the pump with a model of different capacity may damage the system, the motor and the pump itself.

If continuous operation is needed, the pump has to be mounted in an airy space in order to dissipate the heat produced from the motor.

The pump must be mounted horizontally.

To avoid noise and vibrations of mechanical parts, it's advisable to mount the motor on rubber shock-absorbing supports.

The use of the dumper coupling kit for 48YZ frame motors (3000300 for the parallel shaft type, 3000310 for the splined shaft type) is suggested in order to avoid any misalignment between pump and motor.

WIRING THE MOTOR TO THE POWER SUPPLY

- The power supply must be consistent with the electrical data stamped on the motor plate, with particular regard to voltage and frequency. The power supply needs to be switched off during installation.
- The motor rotation must be clockwise (looking the motor in front).
If operated counter-clockwise, the pump won't work. In case the rotation is counter-clockwise, proceed according to the scheme generally enclosed in the electrical wiring box.
- If the pump fails or some estraneous object enters it, the pump-motor unit may stop or work in critical conditions; for this reason the motor should have a thermal protection to avoid overheating or a current protection to avoid overloading.

MOUNTING THE PUMP ONTO THE MOTOR

a) Motor with clamp mounting (type 48YZ)

- Make sure the motor is unplugged from the electric line
- Insert the clamp on the pump (shaft side)
- Clamp the pump to the motor by inserting the pump shaft into the motor shaft and pushing it till it stops
- Turn the pump to the position desired
- Position the clamp in order to surmount the pump and the motor rings
- Tighten the clamp using 1 - 1.5 Nm torque maximum.
- Make sure that the clamp screw is tight enough to prevent the rotation of the pump on the motor.
- Should the pump be noisy during the startup, it is necessary to untighten the clamp screw, reposition the pump and tighten again the clamp screw.

LISTINGS

NSF Listed Pumps are marked PA/MA/CA instead of PO/MO/CO, WRAS listed pumps are marked POW.

The "Compact" series pumps are not equipped with weep holes, therefore the normal condensation may not evaporate. In this case it is necessary coupling the pump to a motor equipped with 4 90° holes in the coupling area.

CERTIFICATIONS

The pump itself, without the motor, is not to be considered as a machine, but only a component, therefore the mark "CE" is not applicable. A conformity declaration may be requested to state the essential safety features ("Machinery Directive" 89/392/CEE). The complete group is instead considered as a machine ready to be used and it is supplied with the mark "CE" that grants its conformity. Product in conformity with the D.M. 174/2004.

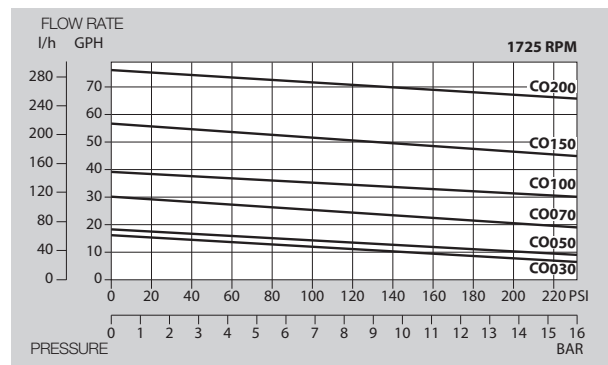
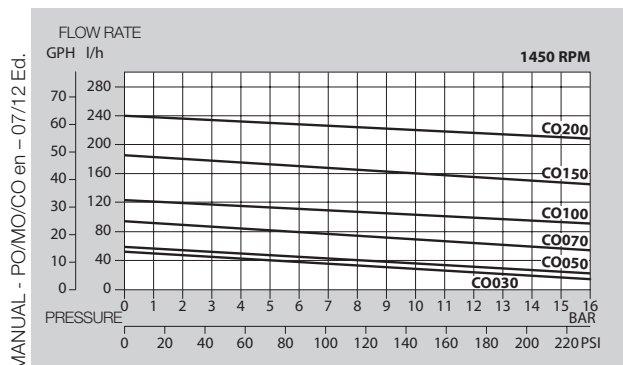
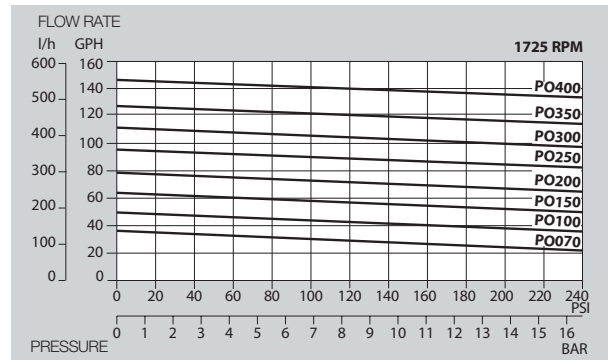
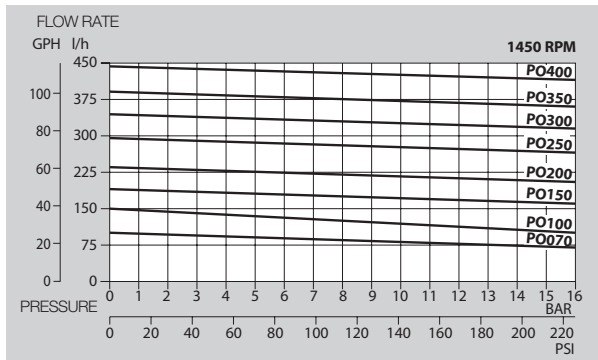
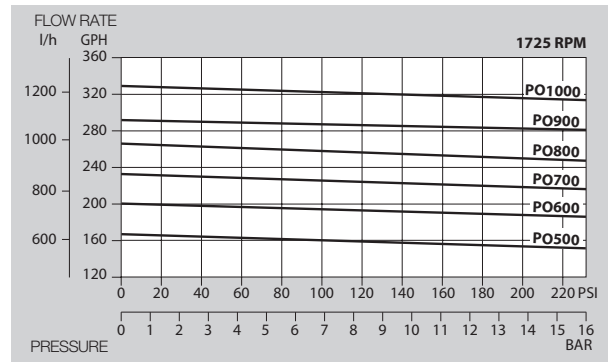
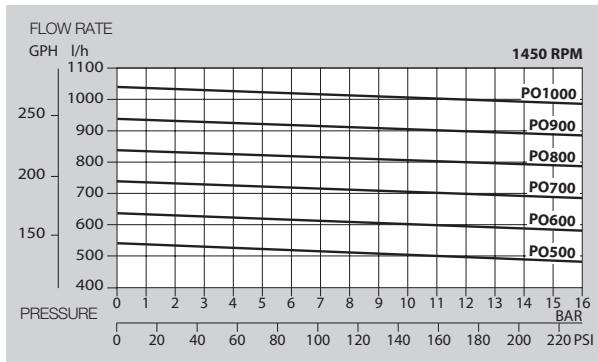

MANUAL - PO/MO/CO en - 07/12 Ed.

The above figures refer to measurements with by pass fully closed. Water temperature 20 °C (68 F). Figures of flow are averages.

Fluid-o-Tech reserves the right to alter the specifications indicated in this catalogue at any time and without prior notice.

Fluid-o-Tech srl
Via Leonardo da Vinci, 40.
20094 Corsico, Milano, Italy
Tel. +39 02 8917071
Fax +39 02 89170799
info@fluidotech.it

Fluid-o-Tech Int'l Inc.
161 Atwater St.,
Plantsville CT (USA) 06479
Tel. +1 (860) 276-9270
Fax +1 (860) 620-0193
info@fluid-o-tech.com

Fluid-o-Tech Int'l Inc. Japan
203, 2-17-19, Ebara, Shinagawa,
Tokyo 142-0063, Japan
Tel. +81 (0) (3) 3783-9660
Fax +81 (0) (3) 3783-9661
k.kato@fluidotech.com

Fluid-o-Tech Asia (Beijing) Co., Ltd
Jingwei Industrial Zone,
Beifang Huairou, Beijing, 101400, PRC
Tel. +86 (0) (10) 61684650
Fax +86 (0) (10) 61684651
info@fluidotech-asia.com

b) Motor with B14 or NEMA 56C mounting

- Make sure that the motor is unplugged from the electric line
- Mount the motor side of the coupling on the motor
- Tighten the set screw (only for the couplings equipped with the set screw)
- Insert the shock absorber in the coupling on the motor side
- Insert the pump side of the coupling in the shock absorber
- Mount the adapter on the motor flange and tighten the screws
- Insert the pump shaft into the coupling
- Position the clamp in order to surmount the pump and the adapter rings
- Turn the pump to the desired position
- Tighten the clamp using 1 - 1.5 Nm maximum torque.
- Make sure that the clamp screw is tight enough to prevent the rotation of the pump on the motor.

The drawing here below illustrates the minimum dimensional requirement of the motor in order to grant the proper alignment between pump and motor. Tool AT-190-1 is available upon request to verify the compliance of the motor to the above mentioned requirement.

CONNECTING THE PUMP TO THE CIRCUIT

It's strongly recommended using, on the inlet port of the pump, pipes and connections of suitable size for the pump capacity, (8 mm for "CO 30-200" pumps with capacities up to 150 l/h, 10 mm for "PO 70-400" series pumps with capacities up to 500 l/h, 15 mm for "PO 500-1000" pumps with capacities up to 1000 l/h.

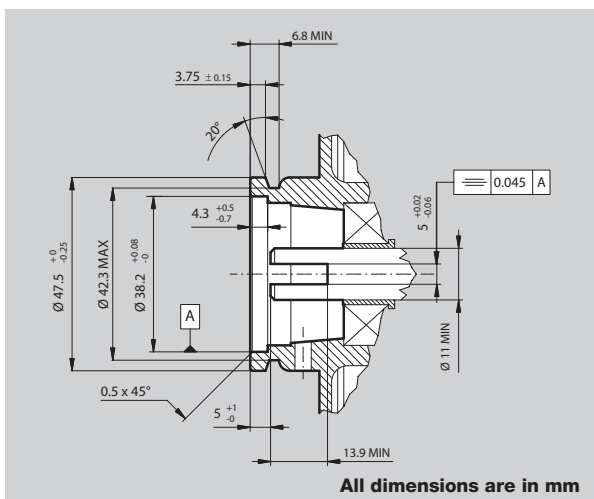

This precaution avoids the possibility of cavitation and consequent damage of the pump. The pumps - although identical in their aspect - may have GAS or NPT threaded ports. The thread of the fitting should match the thread of the pump port. If the pump has GAS threads the sealing is provided by an o-ring which is pressed against the flat surface of the port. With the NPT thread, the sealing is provided by the contact between the threads.

In this case a few turns of PTFE tape around the fittings are necessary. Do not exceed in using PTFE tape as pieces of it may fall into the pump (especially on the Inlet side) and cause the pump to fail. The use of pipe dope (liquid sealant) should be avoided. A particular care is needed while mounting the fittings, to avoid liquid leaks. Hold the pump with a wrench in the area marked with the arrows indicating the inlet-outlet ports and the rotation sense, without over-tightening. It is recommended not exceeding 15 Nm torque when tightening the fittings because the threads on the pump might be damaged.

It is suggested using aluminium sheet on each side of the pump to avoid damage to the ports. Do not use the motor as pump support when tightening the fittings, in order to avoid a possible misalignment and stress of the shafts.

If the pump is made of stainless steel the fittings have to be made of stainless steel or plastic, not in brass, to avoid problems of corrosion. The circuit should be carefully flushed before connecting the pump.

OPERATING CONDITIONS

Make sure that the pumped fluid is compatible with the materials of the pump. For particular applications, please contact the nearest authorized Fluid-o-Tech distributor.

- Avoid as well to use liquids with temperature higher than 70 °C (158 °F).
- The maximum differential pressure must not exceed 16 bar (230 psi).
- The maximum system pressure must not exceed 20 bar (290 psi).
- A circuit layout with elbows and sudden changes in the diameter of the pipes, causes turbulence in the water and resonance in the machine. This is also worsened when the pump is not fed by the main water line.
- Although Fluid-o-Tech may give technical support, the final approval of the pumps is responsibility of the Customer, in fact the performances and reliability may be affected by particular operating conditions and/or hydraulic circuit layout.

USEFUL TIPS FOR A LONG LASTING LIFE OF THE ROTOFLOW PUMPS

The Rotoflow pump is designed to handle clean fluids only. It is recommended for this reason installing before the pump a 10 µm filter with a filtering area big enough, so as not to cause flow-pressure losses in the circuit.

Place the filter at least 50 cm before the inlet port of the pump in order to avoid cavitation.

It is also important to check periodically the filter cartridge. In order to keep the filter under control, it is advisable to install a vacuum gauge before and after the filter. In case the vacuum increases more than 0,1 bar, the cartridge should be cleaned or changed.

A dirty filter or an insufficient supply of water causes cavitation and fast wear of the pump.

The rotary vane pumps are self-priming, but dry running causes overheating and failure of the mechanical seal and of the internal components, and therefore potential leaks.

If the line is subject to scarce pressure or flow it is necessary to fit a low pressure switch before the pump in order to switch the motor off.

In order to avoid cavitation, if the tank is at atmospheric pressure, do not install the pump more than 1 m above the maximum liquid level of the tank.

It is also necessary to protect the system from incidental overpressures with safety devices such as a pressure relief valve or a pressure switch connected to the motor.

If possible it's advisable to install the pump as close as possible to the tank.

The bypass valve is set from the factory at 12 bar (170 psi) unless otherwise requested.

The relief valve is not and must not be used as a flow regulator.

If used as a flow regulator, the water in excess will recirculate inside the pump through the relief valve and the pump will fail.

The maximum differential pressure should be at least 2 bar (29 psi) lower than the relief valve setting in order to avoid operation with the relief valve open.

The maximum differential pressure must not exceed 16 bar (230 psi).

STANDARD MAINTENANCE, SUBSTITUTION OF PARTS SUBJECT TO WEAR

The rotary vane pumps maintenance, and the replacement of the parts subject to wear has to be done by Fluid-o-Tech or authorized repair centers. For the pump with built-in filter it's recommended the periodic cleaning of the filter with alcohol and compressed air.

If the filter is external it's necessary to clean it or to replace it periodically.

A dirty filter doesn't allow the flow of the liquid through it and causes cavitation and fast wear of the internal parts of the pump.

- A few drops of water from the drain holes of the pump are normal during the first hours of operation. In case the leaking persists, contact Fluid-o-Tech.

WARRANTY

Every new pump manufactured by Fluid-o-Tech is guaranteed to be free of defects in workmanship and material when leaving the factory for a period of 12 months from the production date stamped on the pump's housing, plus a period of 3 months to cover the warehouse and transit time, or for a period of maximum 15 months for the purchasing date to the for product use. In no event shall this period exceed 15 months from date of original invoice.

Fluid-o-Tech will repair or replace at its judgement part or all of the product not conforming to this warranty. Fluid-o-Tech's responsibility under this warranty is limited to the repair or replacement of defective equipment returned to us on an F.O.B. basis, providing that our analysis discloses that such part or parts were defective at the time of sale.

The warranty is not recognized if:

- The directions on how to handle, install or operate the pump are disregarded
- The pump has been disassembled or modified by anyone other than a Fluid-o-Tech (or authorized by Fluid-o-Tech) engineer or repaired with non original components
- The pump operated dry or in cavitation
- Solid extraneous particles are found in the pump
- Evident signs of over pressure are observed (over 250 psi for the pumps with flow rate up to 1.000 l/h and 260 psi for the pumps with flow rate between 1.000 l/h and 2.400 l/h)
- The pump has been utilized for an application for which it was not intended to be used where the operating conditions and/or the pumped liquid were incompatible with the pump itself and such application has not been specifically approved by Fluid-o-Tech
- In case of pumps equipped with relief valve, the operating pressure results to be less than 1 bar below the relief valve setting

The adjustment or replacement of defective parts made under this warranty will not extend the original warranty period.

RE2521-BLF

Ultra-low pressure RO element for low TDS water

SPECIFICATIONS:

General Features	Permeate flow rate:	350 GPD (1.3 m ³ /day)
	Stabilized salt rejection:	99.2%
	Effective membrane area:	12 ft ² (1.1 m ²)

1. The stated product performance is based on data taken after 30 minutes of operation at the following test conditions:

- 500 mg/L NaCl solution at 100 psig (0.7 MPa) applied pressure
- 8% recovery
- 77 °F (25 °C)
- pH 6.5–7.0

2. Minimum salt rejection is 99.0%.

3. Permeate flow rate for each element may vary but will be no more than 15%.

4. All elements are vacuum sealed in a polyethylene bag containing 1.0% SBS (sodium bisulfite) solution and individually packaged in a cardboard box.

Membrane type:	Thin-Film Composite
Membrane material:	Polyamide (PA)
Element configuration:	Spiral-Wound, FRP Wrapping

Dimensions

Model Name	A	B	C	D	E	Part Number	
						Inter-connector	Brine Seal
RE2521-BLF	21.0 inch (534 mm)	2.5 inch (64 mm)	0.75 inch (19.1 mm)	1.1 inch (28 mm)	1.1 inch (28 mm)	40000305	40000223



1. Each membrane element supplied with one brine seal, one interconnector (coupler) and four o-rings.
2. All RE2521 elements fit nominal 2.5 inch (64 mm) I.D. pressure vessels.

The information provided in this document is solely for informative purposes. It is the user's responsibility to ensure the appropriate usage of this product. Woongjin Chemical assumes no obligation, liability or damages incurred for the misuse of the product or for the information provided in this document. This document does not express or implies any warranty as to the merchantability or fitness of the product.

Woongjin Chemical Co., Ltd.

For more information on our products, company and regional contacts, please visit our website at www.csmfilter.com.

Product Specification Sheet / Model RE 2521-BLF

Page 1 of 2

RE252 I-BLF

Ultra-low pressure RO element for low TDS water

APPLICATION DATA:

Operating Limits

· Max. Pressure Drop / Element	15 psi (0.1 MPa)
· Max. Pressure Drop / 240" Vessel	60 psi (0.41 MPa)
· Max. Operating Pressure	600 psi (4.14 MPa)
· Max. Feed Flow Rate	6 gpm (1.36 m ³ /hr)
· Min. Concentrate Flow Rate	1 gpm (0.23 m ³ /hr)
· Max. Operating Temperature	113 °F (45 °C)
· Operating pH Range	2.0–11.0
· CIP pH Range	1.0–13.0
· Max. Turbidity	1.0 NTU
· Max. SDI (15 min)	5.0
· Max. Chlorine Concentration	< 0.1 mg/L

Design Guidelines for Various Water Sources

· Wastewater Conventional (SDI < 5)	8–12 gfd
· Wastewater Pretreated by UF/MF (SDI < 3)	10–14 gfd
· Seawater, Open Intake (SDI < 5)	7–10 gfd
· Seawater, Beach Well (SDI < 3)	8–12 gfd
· Surface Water (SDI < 5)	12–16 gfd
· Surface Water (SDI < 3)	13–17 gfd
· Well water (SDI < 3)	13–17 gfd
· RO permeate (SDI < 1)	21–30 gfd

Saturation Limits (Using Antiscalants)[†]

· Langlier Saturation Index (LSI)	<+1.5
· Stiff and Davis Saturation Index (SDSI)	<+0.5
· CaSO ₄	230% saturation
· SrSO ₄	800% saturation
· BaSO ₄	6,000% saturation
· SiO ₂	100% saturation

[†]The above saturation limits are typically accepted by proprietary antiscalant manufacturers. It is the user's responsibility to ensure proper chemical(s) and concentration are dosed ahead of the membrane system to prevent scale formation anywhere within the membrane system. Membrane elements fouled or damaged due to scale formation are not covered by the limited warranty.

GENERAL HANDLING PROCEDURES

- Elements contained in the boxes must be kept dry at room temperature (7–32°C; 40–95°F) and should not be stored in direct sunlight. If the polyethylene bag is damaged, a new preservative solution (sodium bisulfite) must be added and air-tight sealed to prevent drying and biological growth.
- Permeate from the first hour of operation should be discarded to flush out the preservative solution.
- Elements should be immersed in a preservative solution during storage, shipping and system shutdowns to prevent biological growth and freezing. The standard storage solution contains 1% by weight sodium bisulfite or sodium metabisulfite (food grade). For short term storage (i.e. one week or less) 1% by weight sodium metabisulfite solution is adequate for preventing biological growth.
- Keep elements moist at all times after initial wetting.
- Avoid excessive pressure and flow spikes.
- Only use chemicals compatible with the membrane elements and components. Use of such chemicals may void the element limited warranty.
- Permeate pressure must always be equal or less than the feed/concentrate pressure. Damage caused by permeate back pressure voids the element limited warranty.

Woongjin Chemical Co., Ltd.

For more information on our products, company and regional contacts, please visit our website at www.csmfilter.com.

Product Specification Sheet / Model RE 2521-BLF

Page 2 of 2



Series CXA Water Pump Pressure Switch

Specifications - Installation and Operating Instructions

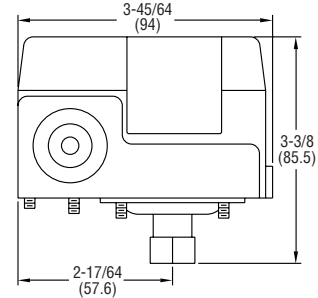
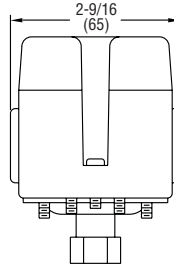

The Series CXA Water Pump Pressure Switches have been proven reliable for controlling automatic water systems. These switches are very popular for use on water well pumps and pumping systems. The set point and deadband are both easily adjustable via screws inside the cover. For ease of installation, the switches come with a 1/4" female NPT process connection and can be mounted in any orientation. The series CXA's simple design makes it a great switch for an installer at any skill level.

SPECIFICATIONS

- Service:** Compatible liquids and gases.
- Wetted Materials:** Silicone, steel, and SS.
- Temperature Limits:** 140°F (60°C).
- Pressure Limits:** See model chart.
- Enclosure Rating:** General purpose.
- Repeatability:** ±5 psig (±0.3 bar).
- Switch Type:** SPST snap action (see model chart).
- Electrical Ratings:** 20A @ 120 VAC, 12A @ 240 VAC, 9.6A @ 240 VAC (3 phase), 8.6A @ 32 VDC, 3.1A @ 120 VDC, 1.6A @ 240 VDC.
- Electrical Connections:** Screw terminal.
- Conduit Connection:** 7/8" hole for 1/2" conduit hub (2 places).
- Process Connection:** 1/4" female NPT.
- Mounting Orientation:** Switch can be installed in any position.
- Setpoint Adjustment:** Internal screws.
- Weight:** 0.75 lb (0.34 kg).
- Deadband:** See model chart.
- Agency Approvals:** CE, UL pending.

MODELS

Model Number	Switch Type	Range psig (bar)	Approx. Adjustable Deadband psig (bar)	Max. Pressure psig (bar)
CXA-S1	NC	15-80 (1.0-5.5)	15-30 (1.0-2.1)	129 (8.9)
CXA-S2	NC	30-100 (2.1-6.9)	20-35 (1.4-2.4)	179 (12.3)
CXA-S3	NC	35-150 (2.4-10.3)	30-40 (2.1-2.8)	204 (14.1)
CXA-R1	NO	15-80 (1.0-5.5)	15-30 (1.0-2.1)	129 (8.9)
CXA-R2	NO	30-100 (2.1-6.9)	20-35 (1.4-2.4)	179 (12.3)
CXA-R3	NO	35-150 (2.4-10.3)	30-40 (2.1-2.8)	204 (14.1)

INSTALLATION/MOUNTING

The switch can be pipe mounted in any position. Do not twist the case when installing. Use a wrench on the pressure connection flats.

WIRING

All wiring must conform to the National Electrical Code and local regulations. Do not install the control to handle loads in excess of electrical rating shown in specifications or as indicated on instructions inside control cover.

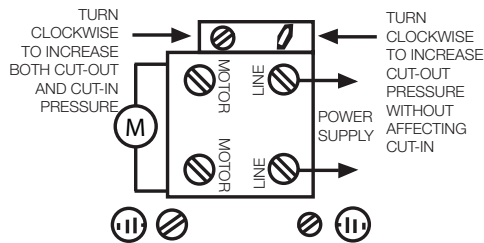

WIRING DIAGRAM

CAUTION: No lubrication or periodic servicing is required. Mount the control securely. Never exceed the electrical rating for the switch. Use the control only with compatible medias.

MAINTENANCE

Upon final installation of the Series CXA Water Pump Pressure Switch, no routine maintenance is required. A periodic check of the system calibration is recommended. The Series CXA is not field serviceable and should be returned if repair is needed (field repair should not be attempted and may void warranty). Be sure to include a brief description of the problem plus any relevant application notes. Contact customer service to receive a return good authorization number before shipping.



2227 South Street • P.O. Box 044170 • Racine, WI 53404-7003

www.Marlo-Inc.com