

'MRO-SW' Seawater Reverse Osmosis Systems

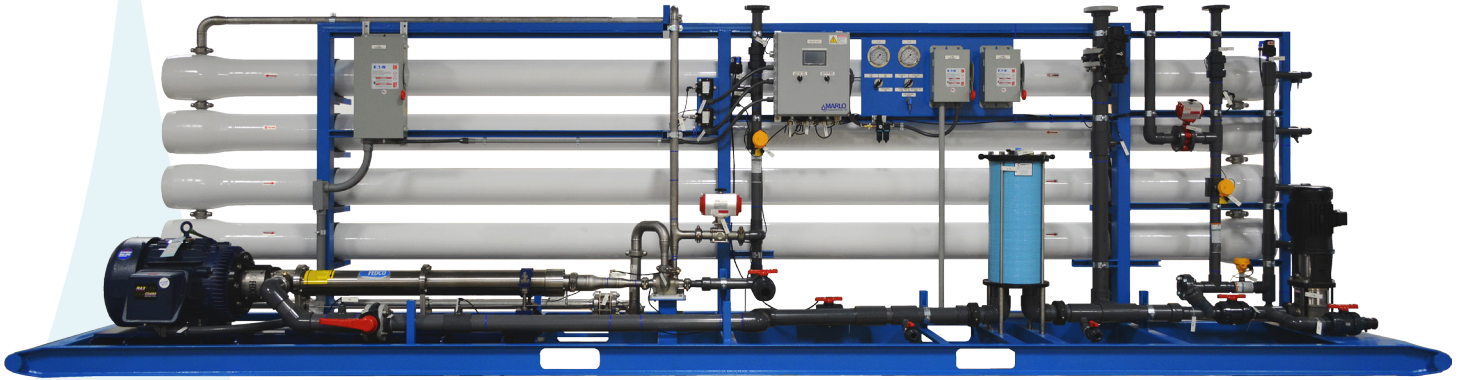

Overview

The MRO-SW series of Reverse Osmosis units are designed to process seawater and provide a high quality freshwater supply for a variety of potable, domestic, and industrial uses. The product platform is very flexible for customization and offers a wide range of output capacities (5,000-300,000 GPD). All components are carefully selected for exceptional performance and energy efficiency while maintaining an economical capital price.

Operating Parameters

- Operating Pressure: 750-1000 psig
- Nominal Recovery: 25-40%
- Operating Temperature: 45-85° F
- Design Temperature: 60° F
- Minimum Inlet Pressure: 40 psig
- Control Circuit: 120 VAC, 1-phase, 60 Hz.

Materials of Construction

- Skid Frame: Epoxy-coated carbon steel
- Membrane Housings: FRP (1000 psig rated)
- Prefilter Housings: Polypropylene or FRP
- Low pressure piping: Sch 80 PVC
- High pressure piping: Duplex Stainless Steel 2205

Pump and Motor

- Pump: Duplex Stainless Steel Axial Piston (models 50K and smaller)
- Pump: Duplex Stainless Steel Multi-Stage Centrifugal (models 75K and larger)
- Motor: TEFC, 460 VAC, 3-phase, 60 Hz.
- Energy Recovery Turbocharger (models 75K and larger)

Standard Features

- High rejection, TFC membrane elements
- 1-micron sediment pre-filter housing
- Allen Bradley MicroLogix 1400 PLC System with PanelView 800 operator interface
- Ethernet/Modbus PLC communications
- Prewired motor starter with fused disconnect switch
- NEMA-12 electrical enclosures
- Automatic product water divert valve
- Product water conductivity transmitter
- Product and reject flow transmitters
- 316SS pressure gauges
- Low inlet pressure switch with alarm
- High pump discharge pressure switch with alarm

Optional Equipment Available

- 380 VAC, 3-phase, 50 Hz power
- Variable Frequency Drives (VFD) (Standard on models 25K and larger)
- NEMA-4 electrical enclosures
- UL-508A Listed electrical panels
- Membrane clean-in-place (CIP) / Flush system
- pH/ORP monitors
- Super duplex stainless steel 2507 high pressure piping
- All stainless steel skid/frame
- Atmospheric storage tanks with level control and repressurization pump systems
- Pretreatment chemical injection systems
- Multi-media / Activated carbon pre-filters
- Export crating

SPECIFICATIONS

MODEL NUMBER	PRODUCT WATER CAPACITY		ELEMENT SIZE	ELEMENT QUANTITY	RO FEED	RO REJECT	SYSTEM PIPING CONNECTIONS (INCHES)			PUMP HP	OVERALL DIMENSIONS (INCHES)			SHIPPING WEIGHT
	GPM	GPD			GPM	GPM	INLET FEED	PRODUCT	RO REJECT		A LENGTH	B WIDTH	C HEIGHT	LBS.
MRO-500K-SW	3.5	5,000	4"x40"	8	11.6	8.1	1"	½"	1"	7.5	144	36	72	3500
MRO-750K-SW	5	7,500	4"x40"	10	17.4	12.2	1"	½"	1"	15	144	36	72	4000
MRO-15K-SW	10	15,000	8"x40"	4	30	20	1½"	1"	1½"	20	120	48	72	8500
MRO-20K-SW	14	20,000	8"x40"	6	40	26	1½"	1"	1½"	20	120	48	72	9000
MRO-25K-SW	17	25,000	8"x40"	8	43	26	2"	1½"	1½"	25	200	50	72	9500
MRO-35K-SW	24	35,000	8"x40"	12	60	36	2"	1½"	2"	50	200	50	72	10,000
MRO-50K-SW	35	50,000	8"x40"	16	87	52	3"	1½"	2"	50	200	50	72	10,500
MRO-75K-SW	52	75,000	8"x40"	18	130	78	3"	2"	3"	60	281	54	78	11,500
MRO-100K-SW	69	100,000	8"x40"	24	173	104	3"	2"	3"	75	281	54	78	12,000
MRO-150K-SW	104	150,000	8"x40"	36	260	156	4"	3"	4"	100	281	62	78	13,000
MRO-200K-SW	139	200,000	8"x40"	48	347	208	4"	3"	4"	125	281	62	78	15,000
MRO-250K-SW	173	250,000	8"x40"	60	434	260	6"	4"	4"	200	300	70	84	18,000
MRO-300K-SW	208	300,000	8"x40"	72	521	313	6"	4"	6"	200	300	70	84	20,500

Front View

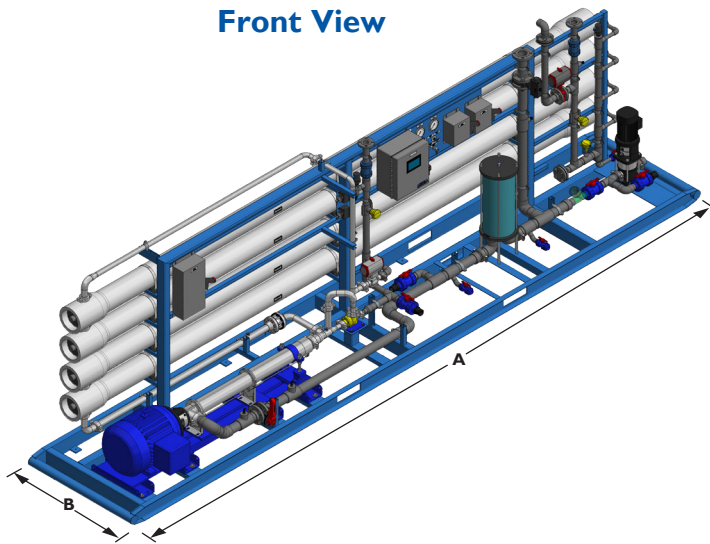

Side View

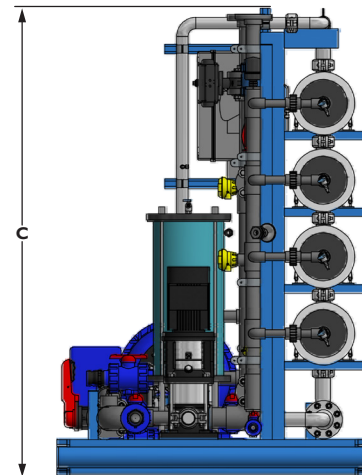

Top View

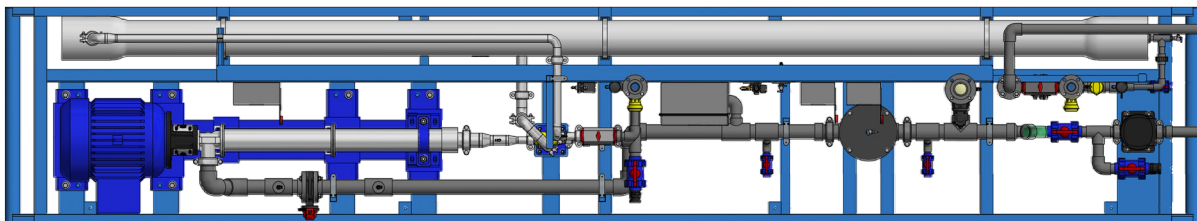

Notes

- ❶ All dimensions and weights shown are approximate and dependent on options selected.
- ❷ Specifications based on seawater at 36,000 ppm TDS and an operating temperature of 60° F.
- ❸ Requires minimum of 48" additional length on each side of the skid for membrane removal.
- ❹ Feedwater to RO system must be free of chlorine and pre-conditioned by polymer injection to prevent membrane scaling.
- ❺ Intake and supply pumps to bring seawater to the RO system are not included.