

CONNECTION SCHEDULE					
ITEM	DESCRIPTION	LOCATION	MAX. FLOW	CONNECTION	MATERIAL
A	HARD WATER INLET	WATER SOFTENER	GPM	NPT	BRASS
B	SOFT WATER OUTLET	WATER SOFTENER	GPM	NPT	BRASS
C	WASTE TO DRAIN	WATER SOFTENER	GPM	NPT	GALV

DIMENSIONS		
LENGTH	WIDTH	HEIGHT

- NOTES:**
1. ALL PIPING, FITTINGS, ETC SHOWN WITH HIDDEN LINES ARE PROVIDED BY OTHERS.
  2. GENERAL PLUMBING CONNECTIONS ARE SHOWN FOR CLARITY ONLY.
  3. PRESSURE VESSELS ARE 100 PSI NON-CODE CONSTRUCTION WITH EPOXY LINED INTERIOR AND FINISH PAINTED EXTERIOR.
  4. PRESSURE VESSEL INTERIOR DISTRIBUTION SYSTEM IS SCH 80 PVC.
  5. SOFTENER RESIN AND SUPPORT GRAVEL IS SHIPPED SEPARATELY AND IS TO BE LOADED AFTER INSTALLATION.
  6. FLECK VALVES HAVE NXT2 CONTROLLERS.

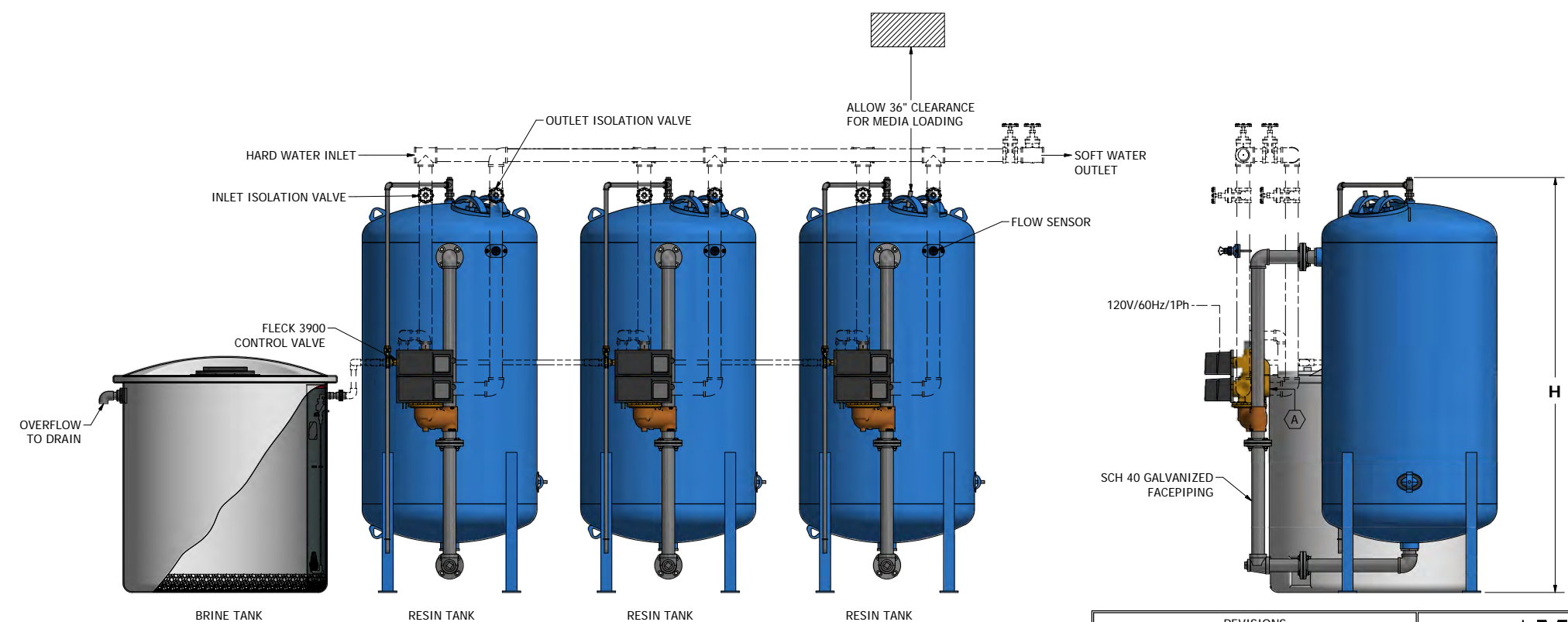
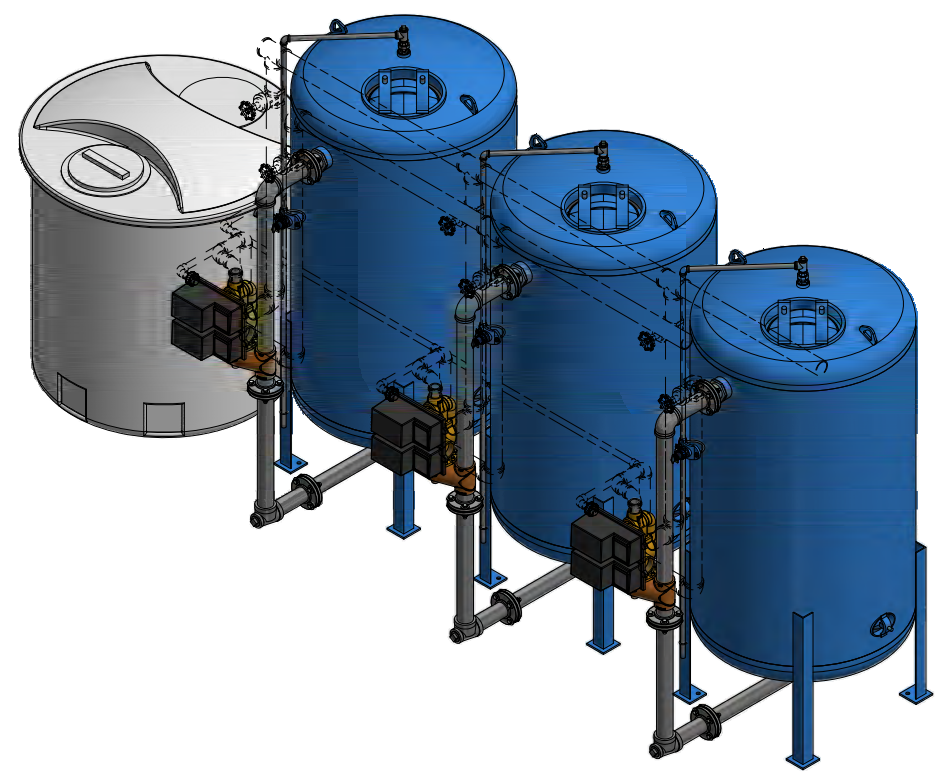
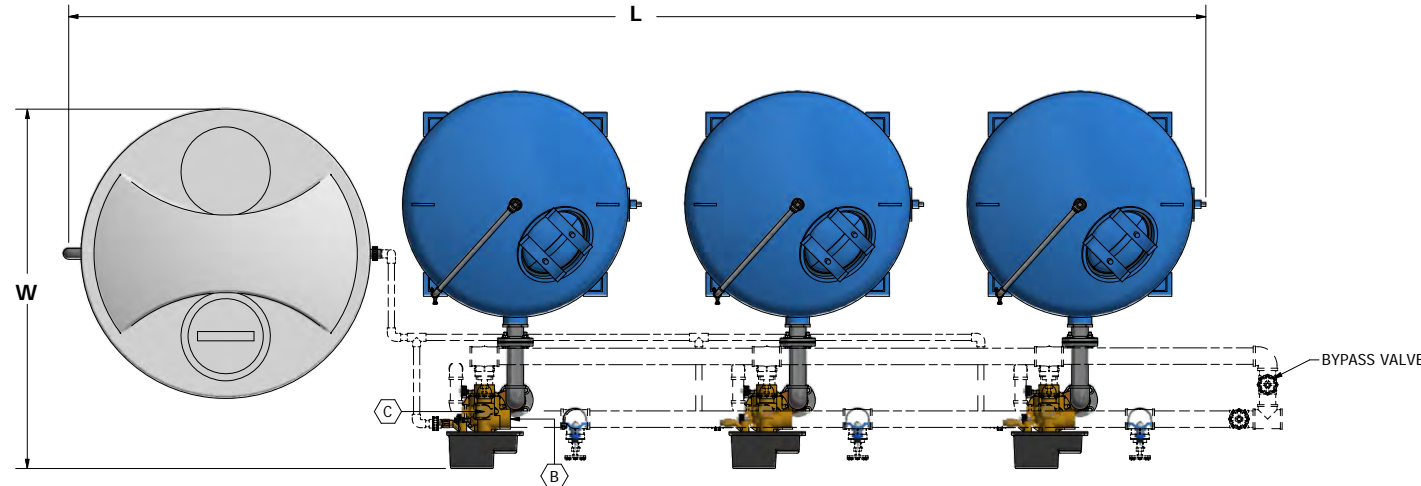

REVISIONS			
NO.	DATE	BY	REMARKS
1	3/18/2019	MRW	REVISED PIPING



MST TRIPLEX PROGRESSIVE WATER SOFTENER - SIDE MOUNT GENERAL ARRANGEMENT			
FRAC. #	DEC. #	FILE ID.	
DRN. #	MRW	SCALE	SHEET 1 OF 1
APPD. #	BCD	DRAWING NO.	
DATE	12/19/2018		

**PRELIMINARY - NOT FOR CONSTRUCTION**