



**“CTC”  
Series  
Time Clock**

**AUTOMATIC WATER  
CONDITIONERS**

---

---

**INSTALLATION, OPERATION, AND  
MAINTENANCE MANUAL**

---

---

FILL IN FOR FUTURE REFERENCE

MODEL NO: _____
SERIAL NO: _____
DATE INSTALLED: _____
DEALER: _____



# “CTC” Series Automatic Water Conditioners

## ( “CTC” SERIES ) SPECIFICATION TABLE

Model Number	Units	CTC-22K	CTC-30K	CTC-40K	CTC-45K	CTC-60K	CTC-24KC	CTC-30KC
Exchange Capacity Kilograms	MAX	22,836	30,448	38,060	45,672	60,896	22,836	30,448
	MID	19,509	26,012	32,515	39,018	52,024	19,509	26,012
	MIN	14,514	19,352	24,190	29,028	38,704	14,514	19,352
Salt Per Regeneration Lbs. / Regen.	MAX	11.25	15.00	18.75	22.50	30.00	11.25	15.00
	MID	8.00	10.00	13.00	15.00	20.00	8.00	10.00
	MIN	4.00	5.00	6.00	8.00	10.00	4.00	5.00
Max Service Flow (1)	GPM	16.00	15.00	16.00	17.00	20.00	16.00	15.00
Pipe Size In - Out Drain	INS	1"	1"	1"	1"	1"	1"	1"
	INS	¾"	¾"	¾"	¾"	¾"	¾"	¾"
Operating Pressure Range	PSI	30-125	30-125	30-125	30-125	30-125	30-125	30-125
Maximum Operating Temperature	DEG F	110	110	110	110	110	110	110
Mineral Tank Size (Dia. x Ht.) (2)	INS.	8 x 44	9 x 40	10 x 47	10 x 54	12 x 52	8 x 35	10 x 35
Brine Tank (Dia. x Ht.) (3)	INS.	18 x 33	18 x 33	18 x 33	18 x 40	18 x 40		
Salt Storage	LBS.	375	375	375	375	450	250	250
Resin Volume	CU FT.	0.75	1.00	1.3	1.5	2.00	0.75	1.00
Electrical	VOLT. / FREQ.	120 Volts 60 Hz						
Injector	COLOR / CODE	Violet/C	Red/D	White/E	White/E	Blue/F	Violet/C	White/E
Shipping Weight	LBS.	72	105	110	119	137	77	91
Floor Space	INS.	27 x 18	28 x 18	29 x 16	29 x 16	31 x 18	13.5 x 22.5	13.5 x 22.5
Overall Ht.	INS.	52	56	54	62	60	42	42
Max. Drain Flow During Regeneration	GPM	1.7	2.2	2.7	2.7	3.2	1.7	2.7
Regeneration Waste Volume (6)	GAL.	60	80	95	95	120	60	75

NOTE:

- (1) Pressure drop not to exceed 15 psi.
- (2) Pressure vessels are seamless and made of reinforced fiberglass, pressure tested at 300 psi.
- (3) Brine tanks are fabricated of seamless, rigid, tough, high impact, non-toxic polyethylene.
- (4) Product materials and workmanship are protected with a written warranty.
- (5) Untreated water provided during all steps of regeneration.
- (6) Waste water volumes based on "normal" length regeneration, 15 lb./cu.ft. salt dosage, 50 psi inlet pressure.

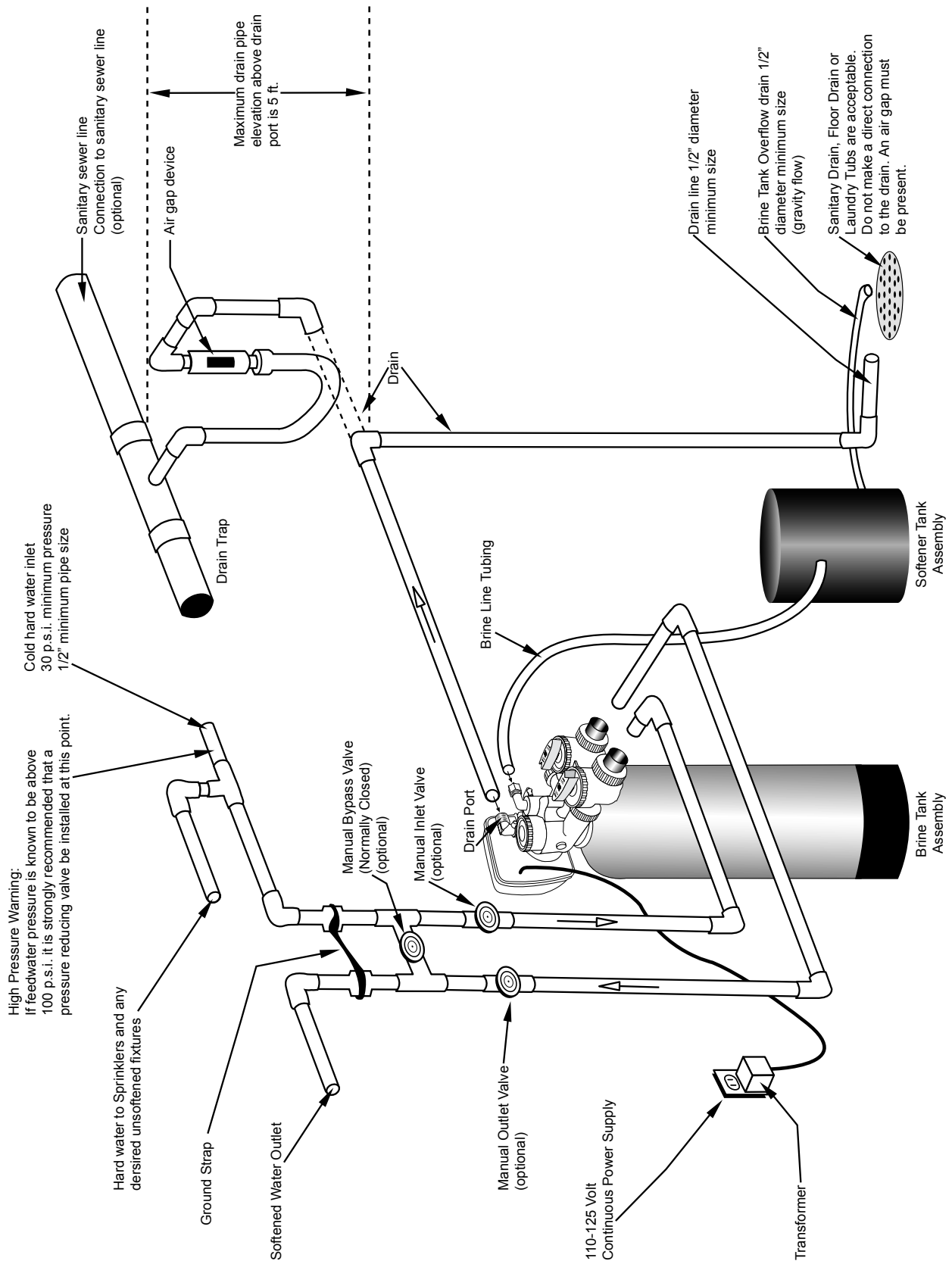

**Typical Water Softener Installation**



# “CTC” Series Automatic Water Conditioners

---

## **Installation Fitting Assemblies**

Installation fittings connect to the control valve or the bypass valve **using nuts that only require hand tightening.** Hand tight nut connections between control valve and installation fittings, control valve and bypass valve, and bypass valve and installation fittings allow for ease serviceability. Do not use a pipe wrench to tighten nuts on installation fittings. **Hand tighten only.**

Split ring retainer design holds the nut on and allows load to be spread over the entire nut surface area reducing the chance for leakage. The split ring design, incorporated into the installation fittings allows approximately 2 degrees off axis alignment to the plumbing system. The installation fittings are designed to accommodate minor plumbing misalignments but are not designed to support the weight of a system or the plumbing.

When assembling the installation fitting package, connect the fitting to the plumbing system first and then attach the nut, split ring and o-ring. Heat from soldering or solvent cements may damage the nut, split ring or o-ring. Solder joints should be cool and solvent cements should be set before installing the nut, split ring and o-ring. Avoid getting primer and solvent cements on any part of the o-rings or split rings, bypass valve or control valve. Solvent cements and primers should be used in accordance with the manufacturer’s instructions.

Slip the nut onto the fitting first, then the split ring second and the o-ring last. hand tighten the nut. If the fitting is leaking, tightening the nut will not stop the leak. Remove the nut, remove the fitting, and check for damage or misalignment of the o-ring.

**Do not** use the pipe dope or other sealant on threads. Teflon tape must be used on the threads of the 1” NPT elbow and the 1/4” NPT connection and on the threads for the drain line connection. Teflon tape is not necessary on the nut connection or caps because of o-ring seals.

**Do not** use Vaseline, oils or other unacceptable lubricants on o-rings. A silicon lubricant may be used on black o-rings.

## **Bypass Valve**

The bypass valve easily connects to the control valve body using nuts that only require hand tightening. Hand tighten nut connections between control valve and fittings, control valve and bypass valve, and bypass valve and installation fittings allow for easy serviceability. The split ring retainer design holds the nut on and allows load to be spread over the entire nut surface area reducing the chance for leakage. The split ring design, incorporated into the bypass, allows approximately 2 degrees off axis alignment to the plumbing system. The bypass is designed to accommodate minor plumbing misalignments but is not designed to support the weight of a system or the plumbing.

Avoid getting primer and solvent cements on any part of the o-rings or split rings, bypass valve or control valve. Do not use pipe dope or other sealant on threads. Teflon tape is not necessary on the caps because of o-ring seals.

Do not use Vaseline, oil or other unacceptable lubricants on o-rings. A silicon lubricant may be used on black o-rings.

## A. GENERAL

1. Shut off all water at main supply valve.
2. **Shut off the fuel supply to water heater.**
3. Open faucets (hot and cold) nearest pump or water meter to relieve pressure and drain system.
4. Move softener into the installation position. Loosely attach all fittings to measure for bypass valve assembly (if used), or manual bypass valve.
5. Level the unit. Place shims under cabinet or brine tank as needed.  
**(Do Not use metal shims.)**
6. Cut the **cold water** supply line as required.
7. Install the bypass valve assembly if used.

## B. PLANNING INSTALLATION

1. All installation procedures must conform to local plumbing, electrical and sanitation codes and ordinances.
2. It is recommended that outside faucets for lawn service be on the hard water line, ahead of the softener, to conserve softened water, save salt and prevent lawn damage.
3. If this isn't practical, use the convenient integral bypass valve assembly.  
**CAUTION: The inlet water temperature MUST NOT exceed 120° F.**
4. Do not locate softener where ambient temperature drops below 40° F.
5. Allow space around the softener for ease of servicing.
6. The softener drain lines must never be solidly connected to the sewer line. (Always provide an air gap at the END of the drain line). Valve drain line must not be elevated over 5' from the top of the softener on well systems, and not over 8' on municipal water systems.
7. The salt storage cabinet or brine tank is a gravity drain, and this drain line must be lower than the drain fitting on the side wall of the cabinet.
8. Move the softener into position and connect to bypass assembly (if used). The integral manual bypass option is a connection which eliminates the need for a 3-valve manifold. This makes installation easier and provides a more convenient method of bypassing.
9. **IMPORTANT:** Be sure that the water inlet line is connected to the “inlet” side of the bypass valve or to the inlet fitting. (Bypass valve both inlet/outlet fittings are marked.) If water lines are reverse, (inlet/outlet) resin may be forced from the water softener into the household plumbing system. If this occurs, household plumbing system must be flushed clean.

## C. CONNECT ALL FITTINGS (refer to previous page)

**CAUTION:** Care must be used when working with copper tubing. Do not allow the flame from torch to contact any portion of the Valve assembly.

1. Attach 1/2” drain line to drain elbow with insert and nut.
2. Do not elevate the drain line over 5' above the top of the valve (8' on municipal systems) or to exceed 25' in length at either height.  
**CAUTION:** An air gap must be provided upon sewer entry. (Conform to local plumbing and sanitation codes and ordinances).
3. The salt storage cabinet or brine tank provides an overflow. Attach 1/2” ID flexible plastic tubing to the overflow fitting and direct it to the drain. **DO NOT** connect to the main drain line-use a separate gravity flow line.







## D. PRESSURE TEST THE INSTALLATION

The plumbing system can now be checked for any possible leaks

1. Put the unit into backwash. To do this, push and hold the REGEN button for 3-5 seconds and unplug the unit. With water supply off, put the bypass into the service position.
2. Open water supply line valve very slowly. Water should escape slowly from the drain line. If water enters too quickly, resin may be lost to the drain.
3. When all of the air has been purged from the mineral tank(water flows steadily from the drain) open the main supply valve fully.
4. Allow water to run to drain until clear. CHECK FOR LEAKS!
5. Plug the unit back in.
6. Manually step the unit through the remaining steps, stopping at the fill cycle (to do this, push the REGEN button. The unit will say Brine on the screen). Once the piston has stopped moving, push the REGEN button again to the next cycle. Continue until Fill appears on the screen. The unit will now fill the brine tank to the appropriate level.
7. Allow control to return to the home position.
8. Check for leaks!
9. Make sure the power cord is plugged into a properly grounded wall receptacle.

## E. MANUAL REGENERATION

Sometimes there’s a need to regenerate your water softener sooner. The user can initiate manual regeneration. The user has the option to request a manual regeneration at the delayed regeneration time or to have the regeneration occur immediately:

1. Press the  &  buttons. An arrow will point on the display to REGEN. Regeneration will occur at the delayed regeneration time. The user can cancel the request by pressing and releasing the  &  buttons.
2. Pressing and holding the  &  buttons for approximately 4 seconds will immediately start the regeneration. The user cannot cancel this request.

### Regeneration Mode



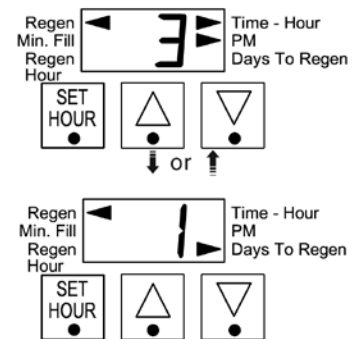

Typically a system is set to regenerate at a time of low water usage. An example of a time with low water usage is when a household is asleep. If there is a demand for water when the system is regenerating, untreated water will be used.

When the system begins to regenerate, the display will change to include information about the step of the regeneration process. The system runs through the steps automatically and will reset itself to provide treated water when the regeneration has been completed.



### Manual Regeneration

Sometimes there is a need to regenerate the system, sooner than when the system calls for it, usually referred to as manual regeneration. There may be a period of heavy water usage because of guests or a heavy laundry day.

To initiate a manual regeneration at the preset delayed regeneration time, press and release  and . An arrow point on the display indicates that the system will regenerate at the preset delayed regeneration time. If you pressed the  and  buttons in error, pressing the buttons again will cancel the request.

To initiate a manual regeneration immediately, press and hold the “REGEN” button for hree seconds. The system will begin to regenerate immediately. The request cannot be cancelled.

Note: For softeners, if brine tank does not contain salt, fill with salt and wait at least two hours before regenerating.



# “CTC” Series Automatic Water Conditioners

## Control Valve Function and Cycles of Operation

This glass filled Noryl<sup>1</sup> fully automatic control valve is designed as the primary control center to direct and regulate all cycles of a water softener or filter. When the control valve is set up as a softener, the control valve can be set to perform down flow or up flow regeneration with the proper piston. When the control valve is set up as a filter, the control valve can be set to perform down flow regeneration or simply backwash. The control valve can be set to regenerate on demand (consumption of a predetermined amount of water) and/or as a time clock (passage of a particular number of days). The control valve can be set so that the softener can meet the Water Quality Association (WQA) or NSF International efficiency rating.

The control valve is compatible with a variety of regenerants and resin cleaners. The control valve is capable of routing the flow of water in the necessary paths to regenerate or backwash water treatment systems. The injector regulates the flow of brine or other regenerants. The control valve regulates the flow rates for backwashing, rinsing and the replenishing of treated water into a regenerant tank, when applicable.

The control valve is designed to deliver high service (27 gpm @ 15 psig) and backwash (27 gpm @ 25 psig) flow rates when the bypass has straight fittings and a 1.050" distributor. The control valve uses no traditional fasteners (e.g. screws), instead clips, threaded caps, nuts and snap type latches are used. Caps and nuts only need to be firmly hand tightened because radial seals are used. Tools required to service the valve include one small blade screwdriver, pliers and a pair of hands. Disassembly for servicing takes much less time than comparable products currently on the market. Control valve installation is made easy because the distributor tube can be cut 1/2" above to 1/2" below the top of the tank thread. The distributor tube is held in place by an o-ring seal and the control valve also has a bayonet lock feature for upper distributor baskets.

The transformer power pack comes with a 15-foot power cord and is designed for use with the control valve. The transformer power pack is for dry location use only. The control valve remembers all settings for two hours if the power goes out. After two hours, the only item that needs to be reset is the time of day; all other values are stored in the memory. The control valve does not need batteries.

Table 3 shows the order of the cycles when the valve is set up as a softener. When the control valve is used as a down flow softener, two backwashes always occur. When the control valve is used as an up flow softener, only one backwash occurs after brining. The installer has the option of having the regenerant refill after the rinse cycle or have the regenerant prefill before regeneration. If the installer chooses to have the regenerant prefill before regeneration, the prefill starts two hours before the regeneration time set. During the 2-hour period in which the brine is being made, treated (softened) water is still available. For example: regeneration time = 2:00 A.M., prefill option selected, downflow softener. Fill occurs at 12:00 A.M., start of backwash cycle occurs at 2:00 A.M.

		<b>Down Flow Softener</b>
<b>Grains Capacity / LB NaC1</b>		3500 to 2501
<b>Lbs. NaC1/cu ft resin</b>		7.5 to 1.2
<b>Cycle Time In Minutes</b>	<b>1st Cycle: Backwash Normal</b>	8 minutes
	<b>2nd Cycle: Regenerate</b>	60 minutes
	<b>3rd Cycle: Backwash Normal</b>	8 minutes
	<b>5th Cycle: Rinse</b>	4 minutes
	<b>Total</b>	80

1 - Noryl is a trademark of General Electric

## How To Change Time of Regeneration and Days Between Regeneration

**STEP 1** - From normal mode, press  &  buttons simultaneously for 3 seconds and release.

**STEP 1A** - Regeneration Time:

Set the clock to the hour the regeneration should occur by using the up or down arrow buttons. An arrow will point to p.m. after 12 (factory default is 2 a.m.). Press SET HOUR to go to step 1B.

**STEP 1B** - Setting Days Between Regeneration:

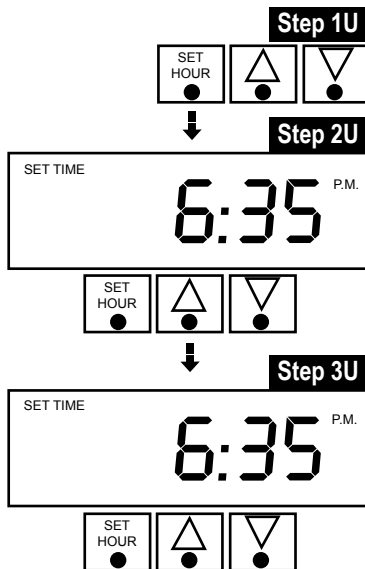

Use the up and down arrow keys to set the days between regenerations (factory default is 3 days). Press SET CLOCK to return to Normal mode.

## How To Set Time Of Day



The user can also set the time of day. Time of day should only need to be set after extended power outages or when daylight saving time begins or ends and at the time of start-up. If an extended power outage occurs, the time of day will flash on and off which indicates the time of day should be reset.

**STEP 1U** - press SET HOUR.

**STEP 2U** - Current Time (hour): Set the hour of the day using  or  buttons. AM/PM toggles after 12.

### Power Loss

If the power goes out for **less than two hours**, the system will automatically reset itself. If an extended power outage occurs, the time of day will flash on and off which indicates the time of day should be reset. The system will retain the other information entered by your plumbing professional.



# FLOW DIAGRAMS

**flow diagram...service**

**flow diagram...backwash**

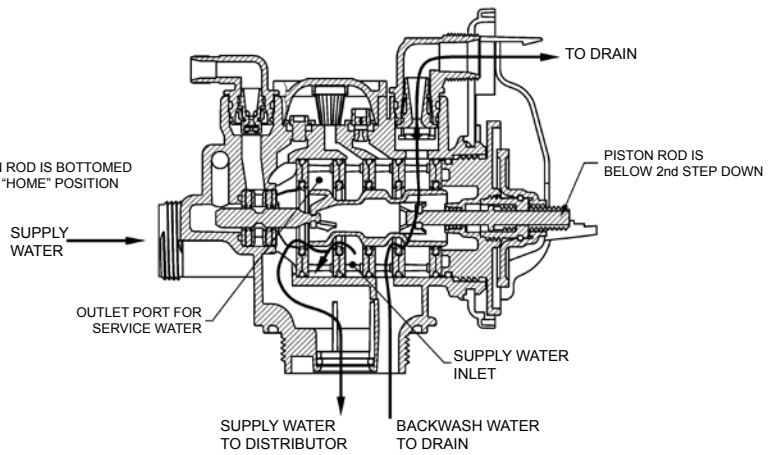
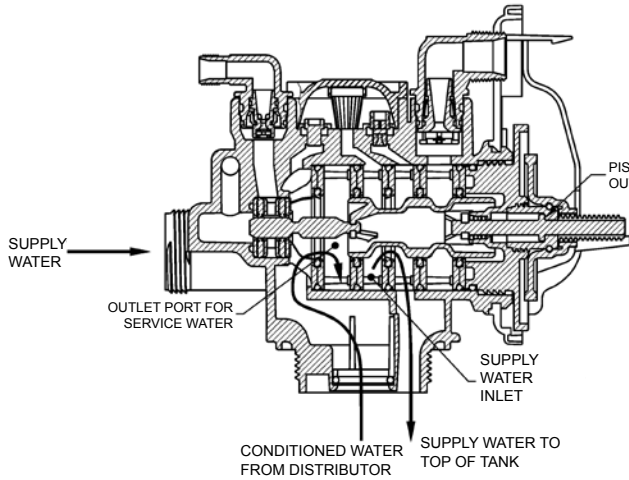

**flow diagram...downflow brine**

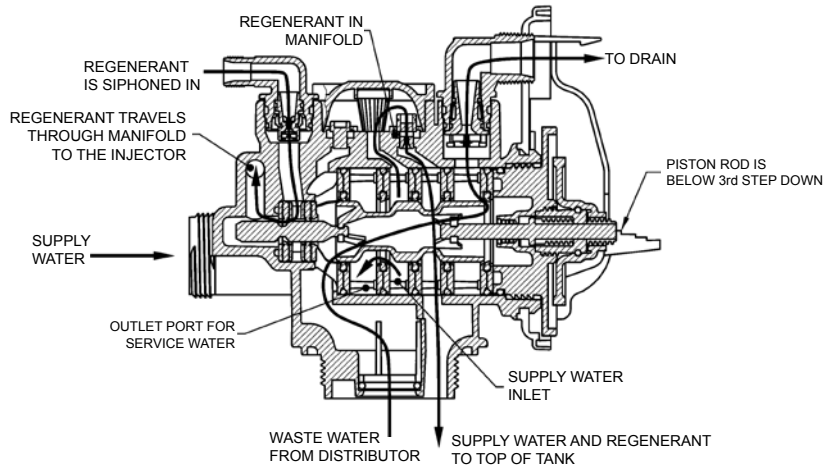

**flow diagram...rinse**

**flow diagram...fill**

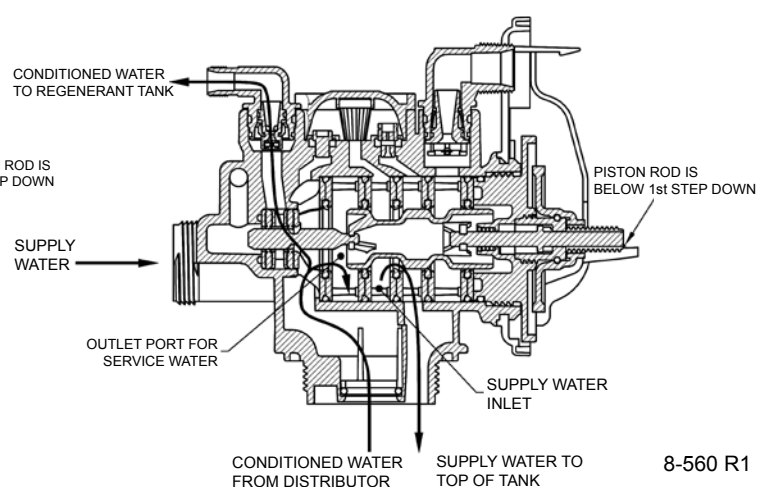
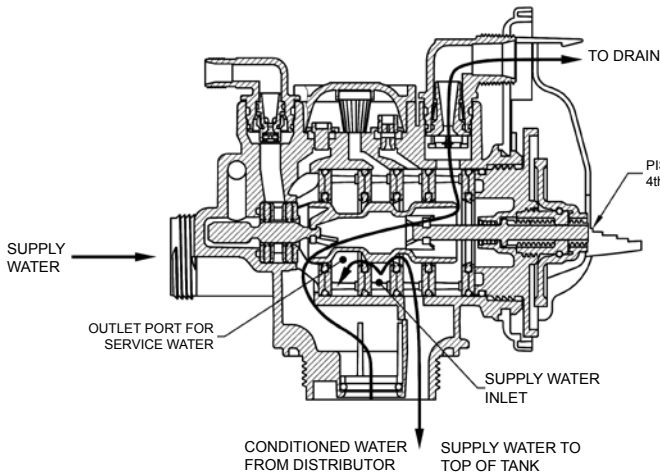

**Bypass Valve**

The bypass valve is typically used to isolate the control valve from the plumbing system’s water pressure in order to perform control valve repairs or maintenance. The WS1 bypass valve is particularly unique in the water treatment industry due to its versatility and state of the art design features. The 1” full flow bypass valve incorporates four positions including a diagnostic position that allows service personal to work on a pressurized system while still providing untreated bypass water to the facility or residence. Its completely non-metallic, all plastic, design allows for easy access and serviceability without the need for tools.

The bypass body and rotors are glass filled Noryl and the nuts and caps are glass filled polypropylene. All seals are self-lubricating EPDM to help prevent valve seizing after long periods of non-use. Internal o-rings can easily be replaced if service is required.

The bypass consists of two interchangeable plug valves that are operated independently by red arrow shaped handles. The handles identify the flow direction of the water. The plug valves enable the bypass valve to operate in four positions.

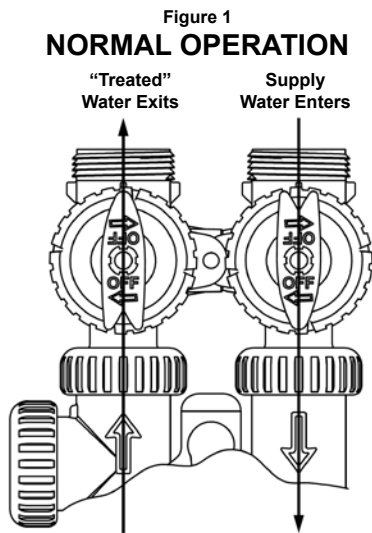

**Normal Operation:**

The inlet and outlet handles point in the direction of flow indicated by the engraved arrows on the control valve. Water flows through the control valve during normal operation and this position also allows the control valve to isolate the media bed during the regeneration cycle.

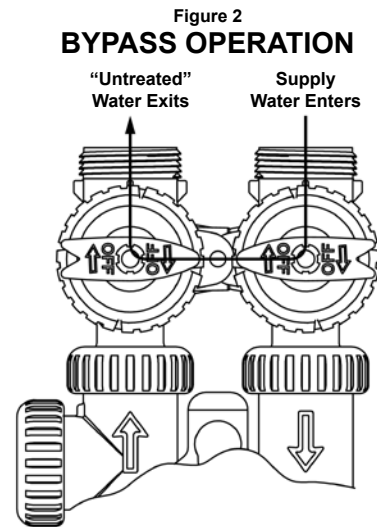

**Bypass:**

The inlet and outlet handles point to the center of the bypass, the control valve is isolated from the water pressure contained in the plumbing system. Untreated water is supplied to the plumbing system.

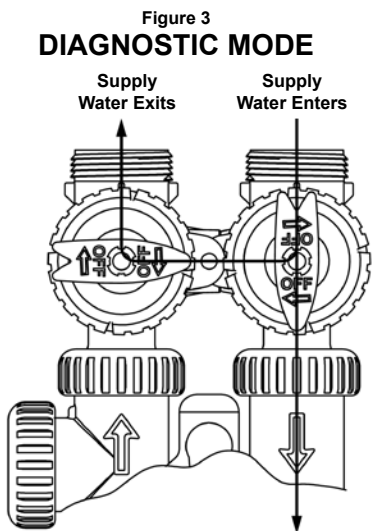

**Diagnostic:**

The inlet handle points in the direction of flow and the outlet handle points to the center of bypass valve, system water pressure is allowed to the control valve and the plumbing system while not allowing water to exit from the control valve to the plumbing.

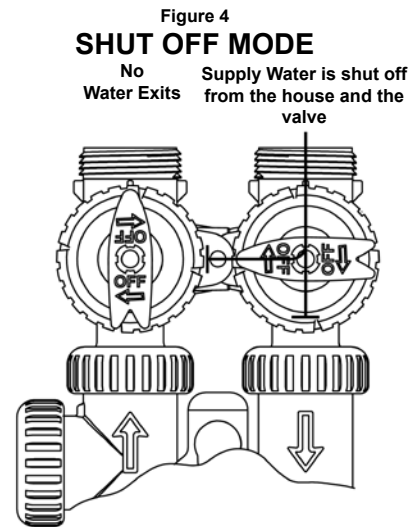

**Shut Off:**

The inlet handle points to the center of the bypass valve and the outlet handle points in the direction of flow, the water is shut off to the plumbing system. If water is available on the outlet side of the softener it is an indication of water bypass around the system (i.e. a plumbing connection somewhere in the building bypasses the system).

## "C" Series

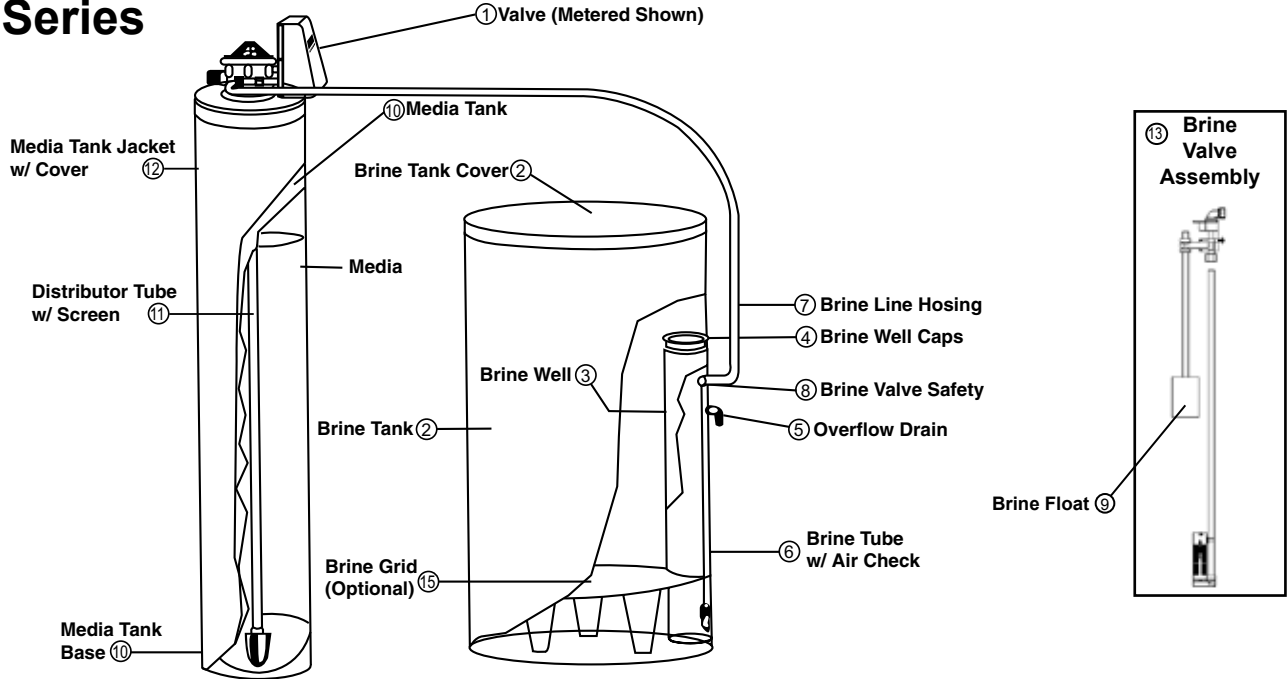

### Parts Listing

Part Number	No.	Description		
Contact Factory	1	Valve Timeclock (Complete - Specify Model)		
A2042018	2	Brine Tank w/ Cover		
A2071005	3	Brine Well		
A2072003	4	Brine Well Cap		
A2250003	5	Overflow Elbow		
A2118010	6	Brine Tube w/ Air Check		
B1020001	7	Brine Line Hose w/ Inserts		
A2005058	8	Brine Valve Safety		
A2107022	9	Brine Float		
A2126012	10	8 x 44 Media Tank - w/ Base	CTC-22-K	
A2126017	10	9 x 40 Media Tank - w/ Base	CTC-30-K	
A2126019	10	9 x 48 Media Tank - w/ Base	CTC-40-K	
A2126023	10	10 x 47 Media Tank - w/ Base	CTC-40-K if built after 06-01-04	
A2126024	10	10 x 54 Media Tank - w/ Base	CTC-45-K	
A2126031	10	12 x 52 Media Tank - w/ Base	CTC-60K	
A2126023	10	10 x 47 Media Tank - w/ Base	CTC-25 Combo	
Contact Factory	--	Media (Specify Model)		
B1023056	11	Distributor Tube Assembly - Specify Model		
B1229004	11	Distributor Tube Assembly - for CTC-25 combo		
B1024011	12	Media Tank Jacket	CTC-22-K	8" Dia., Almond
B1024033	12	Media Tank Jacket w/ cover	CTC-30K	9" Dia., Almond
B1024007	12	Media Tank Jacket w/ cover	CTC-40-K	9" Dia., Almond
B1024013	12	Media Tank Jacket w/ cover	CTC-45-K	10" Dia., Almond
B1024016	12	Media Tank Jacket w/ cover	CTC-60-K	12" Dia., Almond
B1024010	12	Media Tank Jacket	CTC-25 Combo & CTC 40-K if built after 06-01-04	
B1017003	13	* Brine Valve Assembly - Complete - Includes #'s		
A2354023	14	*1" Bypass - Does not include fitting kit (Not Shown)		
A2284002	15	*Grid Set-All (Optional)		
A2121013	16	Media Resin (must also purchase A21220080 garnet [30#].) (used only on CTC Combo model)		
A2122008D	17	Garnet [30#] (used only on CTC 25 Combo model)		

**“C” Series**

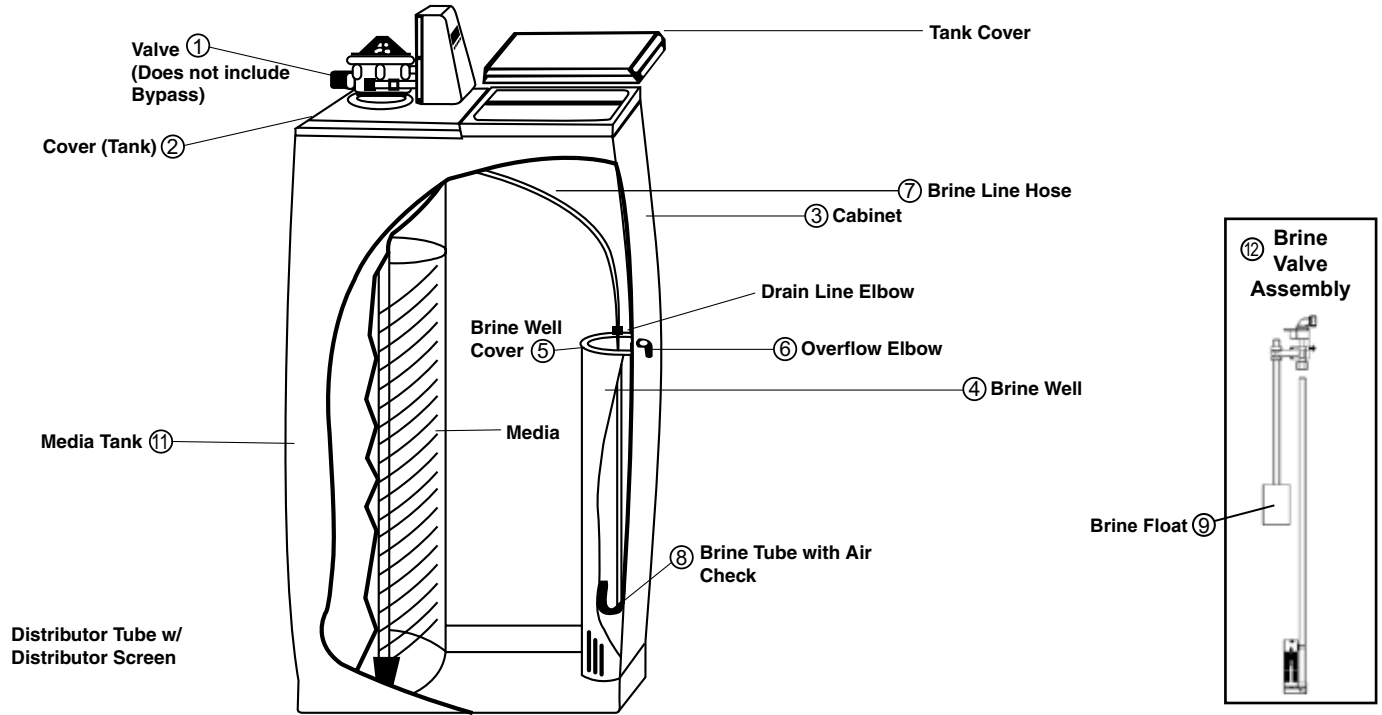

**Parts Listing**

Part Number	Control Number	No.	Description
Contact Factory		1	Valve Timeclock (Complete - Specify Model)
A2103030		2	Cover (Tank) 2 pc.
A2274001		3	Cabinet w/ cover
A2071005		4	Brine Well
A2072003		5	Brine Well Cap
A2250003		6	Overflow Elbow
B1227003		7	Brine Line Hose w/ inserts
A2118010		8	Brine Tube w/ air check
A2005058		9	Brine Valve Safety
A2107022		10	Brine Float
A2255004		11	8 x 35 Media Tank w/Base CTC-22-KC
A2255006		11	1 x 35 Media Tank w/Base CTC-30-KC
Contact Factory		--	Media (Specify Model)
B1017003		--	Distributor Tube W/Distributor Screen (All)
B1017003		12	Brine Valve Assembly - Complete - includes #'s
A2355023		13	*1" Bypass Does not include fitting kit (Not Shown)
B1021009		--	*Grid Set(Optional-Not Shown)

**Drive Cap Assembly, Downflow Piston, Upflow Piston, Regenerant Piston and Spacer Stack Assembly & Front Cover and Drive Assembly**

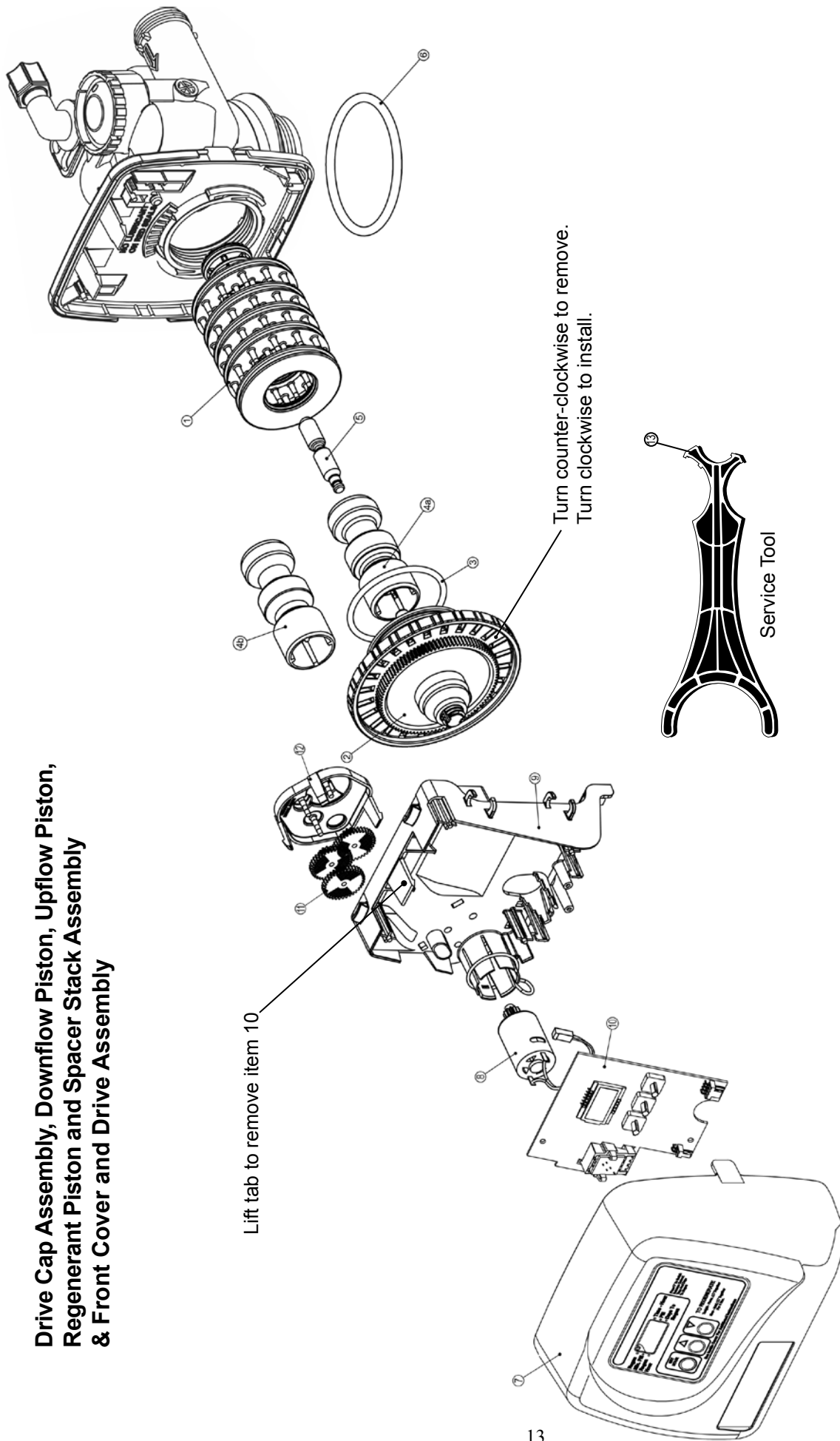

### Drive Cap Assembly, Downflow Piston, Upflow Piston, Regenerant Piston and Spacer Stack Assembly

Item No.	Part No.	Description	Quantity
1	A2466034	*Spacer Stack Assembly w/o o-rings	1
2	A2080077	Drive Cap Assembly	1
◆3	use item 16	O-Ring 228 (use Valve O-ring Kit)	1
▲4	A2309040	Piston Downflow Assembly	1
⊗5	A2438033	Regenerant Piston	1
◆6	use item 51	O-Ring 337 (use Valve O-ring Kit)	1
◆15	use item 51	O-Ring 215 (use Valve O-ring Kit)	1

▲ Item #4 identified with “DN” code.

⊗ Item #5 not used with Backwash Only filter applications.

◆ See page 20 for Valve O-ring Kit.

### Front Cover and Drive Assembly

Item No.	Part No.	Description	Quantity
7	A2103133	Front Cover ASSY	1
8	A2085050	Motor	1
9	A2328046	Drive Bracket & Spring Clip	1
10	A2341017	PC Board	1
11	A2393046	Drive Gear 12 x 36	3
12	A2103132	Drive Gear Cover	1
13	A2491086	Service Tool	1
14	A2242054	Transformer 110V - 12V	1

**Injector Cap, Injector Screen, Injector, Plug ,  
O-Ring, Refill and Refill Port Plug,  
& Drain Line - 3/4”**

◆ Part of Kit, O-ring (Item #51, pg. 20)

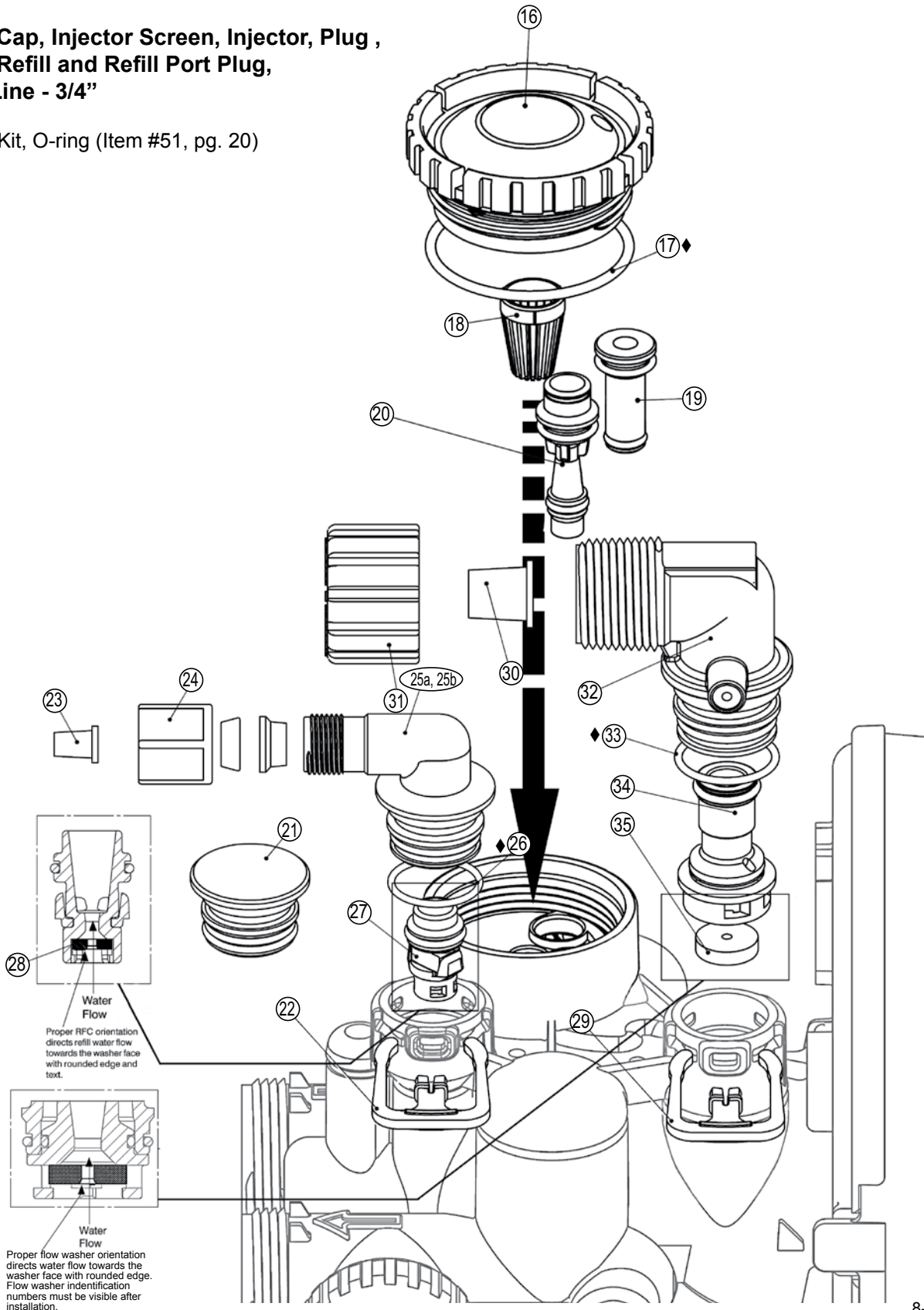

## Injector Cap, Injector Screen, Injector, Plug and O-Ring

Item No.	Part No.	Description		Quantity
16	A2080079	Injector Cap		1
◆17	Use Item 51	O-Ring 135 (Use Valve O-ring Kit)		1
18	A2142016	Injector Screen		1
19	A2079059	Injector Assembly Z Plug	See note	1
20	A2079060	Injector Assembly A Black		
	A2079048	Injector Assembly B Brown		
	A2079046	Injector Assembly C Violet		
	A2079045	Injector Assembly D Red		
	A2079049	Injector Assembly E White		1
	A2079047	Injector Assembly F Blue		
	A2079050	Injector Assembly G Yellow		
	A2079055	Injector Assembly H Green		
	A2079062	Injector Assembly I Orange		
	A2079063	Injector Assembly J Light Blue		
A2079064	Injector Assembly K Light Green			

\*The injector plug and the injector each contain one 011 (lower) and 013 (upper) o-ring.

Note: For downflow brine, injector is located in the down hole and injector plug in the up hole.  
For a filter that only backwashes injector plugs are located in both holes.

## Refill and Refill Port Plug

Drawing No.	Order No.	Description	Quantity
21	A2287059	Refill Port Plug Assembly	This part is required for backwash only systems
22	A2411015	Elbow Locking Clip	1
23	A2409016	Polytube insert 3/8	1
24	A2095071	Nut 3/8	1
25a	A2080078	Elbow Cap 3/8	(use w/ 3/8" tubing) 1
25b	A2129100	Elbow 1/2" with nut and insert	(use w/ 1/2" tubing) Option
◆26	Use Item 51	O-Ring 019 (Use Valve O-ring Kit)	1
27	A2104033	RFC Retainer Assembly*	1
28	A2253108	RFC Brine Refill Flow Washer	1

\*Assembly includes RFC.

## Drain Line - 3/4"

Drawing No.	Order No.	Description	Quantity
29	A2411015	Elbow Locking Clip	1
30	A2409013	Polytube insert 5/8	Option
31	A2095065	Nut 3/4 Drain Elbow	Option
32	A2099056	Drain Elbow 3/4 Male Assembly	1
◆33	Use Item 51	O-Ring 019 (Use Valve O-ring Kit)	1
34	A2104034	Drain Flow Washer Retainer Assembly	1
35	A2253114	Drain Flow Washer 0.7 gpm for 3/4	One DLFC must be used if 3/4 fitting is used
	A2253099	Drain Flow Washer 1.0 gpm for 3/4	
	A2253084	Drain Flow Washer 1.3 gpm for 3/4	
	A2253083	Drain Flow Washer 1.7 gpm for 3/4	
	A2253081	Drain Flow Washer 2.2 gpm for 3/4	
	A2253082	Drain Flow Washer 2.7 gpm for 3/4	
	A2253085	Drain Flow Washer 3.2 gpm for 3/4	
	A2253086	Drain Flow Washer 4.2 gpm for 3/4	
A2253087	Drain Flow Washer 5.3 gpm for 3/4		



## Drain Line - 1”

Drawing No.	Order No.	Description	Quantity
1	A2411015	Elbow Locking Clip	1
2	A2099072	Drain FTG 1” Straight	1
3*	V3166	Drain FTG Body 1”	1
4*	V3167	Drain FTG Adapter 1”	1
5*	A2077179	O-Ring 019	1
6*	A2453012	Split Ring	1
7*	A2095069	Nut 1” Quick Connect	1
8*	A2077178	O-Ring 215	1
9	V3190-065	DLFC 6.5 gpm for 1	One DLFC must be used if 1 fitting is used
	V3190-075	DLFC 7.5 gpm for 1	
	V3190-090	DLFC 9.0 gpm for 1	
	V3190-110	DLFC 11.0 gpm for 1	
	V3190-130	DLFC 13.0 gpm for 1	
	V3190-170	DLFC 17.0 gpm for 1	
	V3190-200	DLFC 20.0 gpm for 1	
	V3190-250	DLFC 25.0 gpm for 1	

\*Can be ordered as a set order number V3008-02, description: WS1 Drain FTG 1 Straight.

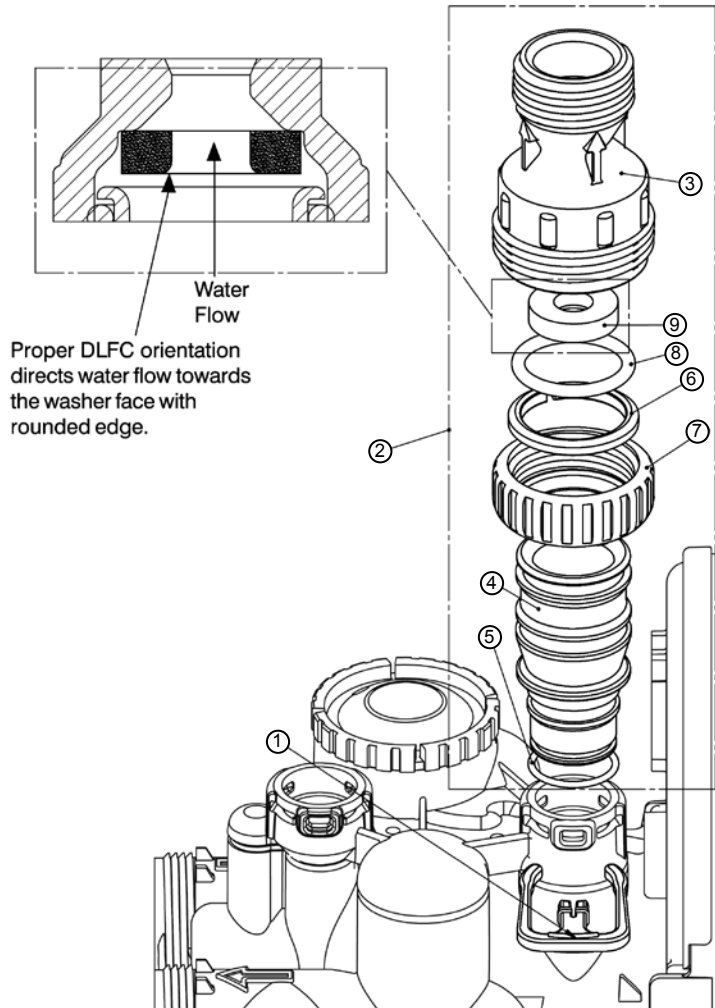

**Water Meter and Meter Plug**

Drawing No.	Order No.	Description	Quantity
1	A2095069	Nut 1" Quick Connect	1
2	A2360039	Meter Assembly - for metered units	1
3	A2100027	Turbine Assembly	1
4	A2077178	O-Ring 215 (Use Valve O-ring Kit)	1
5	V3003-01	Meter Plug Assembly (Time Clock option-Standard)	1

\*Order number A2360039 includes A2100027 and A2077178

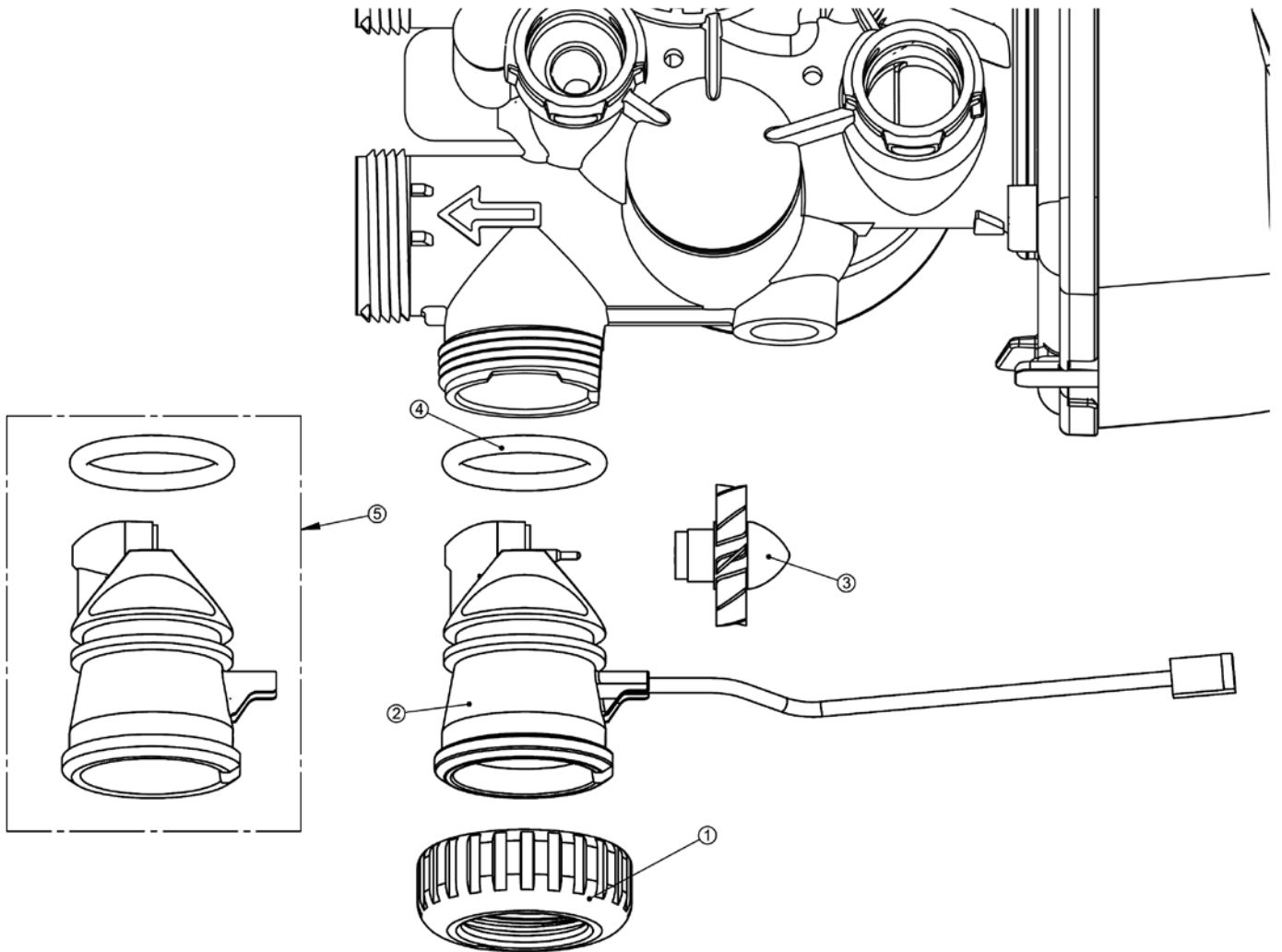

Item No.	Part No.	Description	Quantity
41	A2095069	Nut 1" Quick Connect	2
42	A2453012	Split Ring	2
●43	use item 52	O-Ring 215 (Kit available - see Item #10)	2
44	A2607004	Bypass 1" Rotor	2
45	A2080090	Bypass Cap	2
46	A2395009	Bypass Handle	2
47	A2104036	Bypass Rotor Seal Retainer	2
●48	use item 52	O-Ring 135 (use Bypass Valve Kit)	2
●49	use item 52	O-Ring 112 (use Bypass Valve Kit)	2
●50	use item 52	O-Ring 214 (use Bypass Valve Kit)	2

●Part of Kit, O-ring By-Pass(Item 52)

◆ Valve O-ring Kit

51	B1213022	KIT O-ring (contains 1 each of 3, 6, 15, 17, 26, & 33)	1 per valve
----	----------	--	-------------

● Bypass Valve O-ring Kit

52	B1213021	KIT O-ring Bypass (Incl. 2 ea. of items 43,48,49,& 50)	1 per valve
----	----------	--	-------------

(Not Shown) Order No. A2412076, Description Bypass Vertical Adapter Assembly

Complete Assembly

53	A23540231	Bypass Valve Complete / Less Connectors	1 per valve
----	-----------	---	-------------

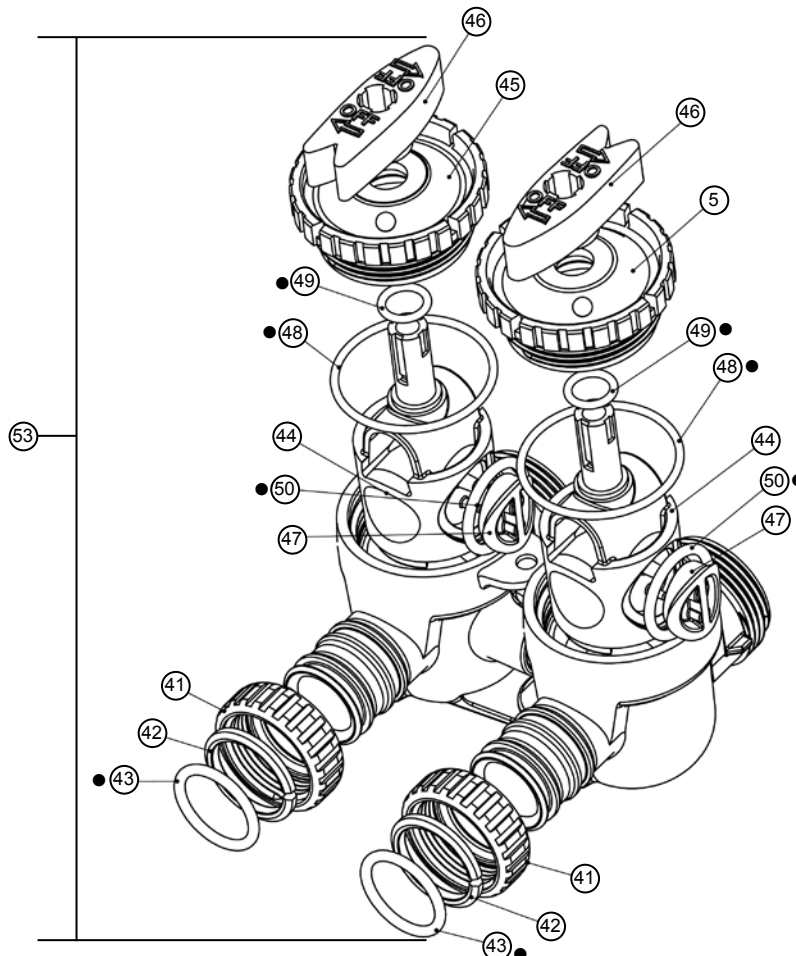

Order No: **A2129080** (Optional)  
 Description: **WS1 Fitting 1” PVC Male NPT Elbow Assembly**

Drawing No.	Order No.	Description	Quantity
1	A2095069	WS1 Nut 1” Quick Connect	2
2	A2453012	WS1 Split Ring	2
3	A2077178	O-Ring 215	2
4	V3149	WS1 Fitting 1” PVC Male NPT Elbow	2

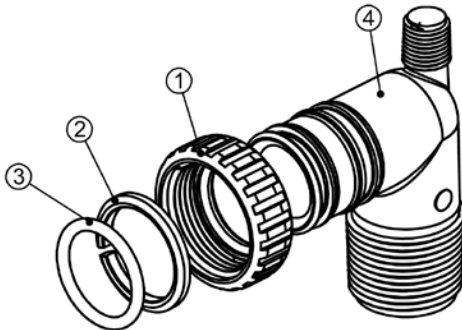

Order No: **A2099054** (Optional)  
 Description: **WS1 Fitting 3/4” & 1” PVC Solvent 90° Asy**

Drawing No.	Order No.	Description	Quantity
1	A2095069	WS1 Nut 1” Quick Connect	2
2	A2453012	WS1 Split Ring	2
3	A2077178	O-Ring 215	2
4	V3189	WS1 Fitting 3/4&1 PVC Solvent 90	2

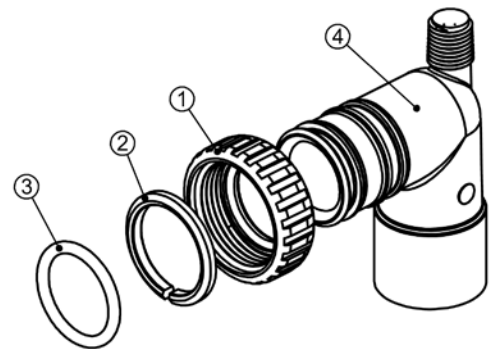

Order No: **A2435068** (Standard)  
 Description: **WS1 Fitting 1” Brass Sweat Assembly**

Drawing No.	Order No.	Description	Quantity
1	A2095069	WS1 Nut 1” Quick Connect	2
2	A2453012	WS1 Split Ring	2
3	A2077178	O-Ring 215	2
4	V3188	WS1 Fitting 1” Brass Sweat	2

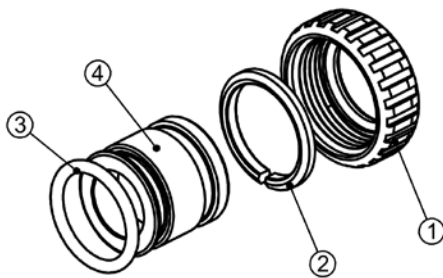

Order No: **A2435072** (Optional)  
 Description: **WS1 Fitting 3/4” Brass Sweat Assembly**

Drawing No.	Order No.	Description	Quantity
1	A2095069	WS1 Nut 1” Quick Connect	2
2	A2453012	WS1 Split Ring	2
3	A2077178	O-Ring 215	2
4	V3188-01	WS1 Fitting 3/4” Brass Sweat	2

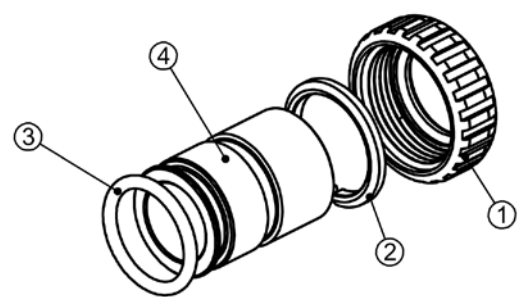

**Table 6  
Troubleshooting Procedures**

Problem	Possible Cause	Solution
1. Timer does not display time of day	a. AC adapter unplugged	a. Connect power
	b. No electric power at outlet	b. Repair outlet or use working outlet
	c. Defective transformer	c. Replace transformer
	d. Defective PC board	d. Replace PC board
2. Timer does not display correct time of day	a. Switched outlet	a. Use uninterrupted outlet
	b. Power outage	b. Reset time of day
	c. Defective PC board	c. Replace PC board
3. Control valve regenerates at wrong time of day	a. Power outages	a. Reset control valve to correct time of day
	b. Time of day not set correctly	b. Reset to correct time of day
	c. Defective PC board	c. Reset regeneration time
4. E1, E2, or E3  E1 - Unable to recognize start of regeneration  E2 - Unexpected stall  E3 - Motor ran too long, timed out trying to reach the next cycle position or trying to reach home position	a. Control valve has just been serviced	a. Press SET HOUR and DOWN for 3 seconds or unplug power source jack (black wire) from the circuit board and plug back in to reset control valve.
	b. Foreign matter is lodged in control valve	b. Check piston and spacer stack assembly for foreign matter.
	c. High drive forces on piston	c. Replace piston(s) and spacer stack assembly
	d. Control valve piston not in home position	d. Press SET HOUR and DOWN for 3 seconds or unplug power source jack (black wire) from the circuit board and plug back in to reset control valve
	e. Motor not inserted fully to engage pinion, motor wires broken or disconnected, motor failure	e. Check motor and wiring. Replace motor if necessary
	f. Drive gear label dirty or damaged, missing or broken gear	f. Replace or clean drive gear
	g. Drive bracket incorrectly aligned to back plate	g. Reseat drive bracket properly
	h. PC board is damaged or defective	h. Replace PC board
	i. PC board incorrectly aligned to drive bracket	i. Ensure PC board is correctly snapped on to drive bracket
	5. Control valve stalled in regeneration	a. Motor not operating
b. No electric power at outlet		b. Repair outlet or use working outlet
c. Defective AC adapter		c. Replace AC adapter
d. Defective PC board		d. Replace PC board
e. Broken drive gear or drive cap assembly		e. Replace drive gear or drive cap assembly
f. Broken piston retainer		f. Replace drive cap assembly
g. Broken main or regenerant piston		g. Replace main or regenerant piston

## Troubleshooting Procedures (continued)

Problem	Possible Cause	Solution
7. Control valve does not regenerate automatically when UP and DOWN button is depressed and held	a. AC adapter unplugged	a. Connect AC adapter
	b. No electric power at outlet	b. Repair outlet or use working outlet
	c. Broken drive gear or drive cap assembly	c. Replace drive gear or drive cap assembly.
	d. Defective PC board	d. Replace PC board
8. Control valve does not regenerate automatically but does when UP and DOWN button is depressed and held	a. Defective PC board	a. Replace PC board
	b. Set-up error	b. Check control valve set-up procedure

## NOTES



2227 South Street  
P.O. Box 044170  
Racine, WI 53404-7003  
Ph. (262) 681-1300  
Fax (262) 681-1318  
[www.Marlo-Inc.com](http://www.Marlo-Inc.com)